

# SILICON PLANAR EPITAXIAL NPN/PNP TRANSISTORS

## BUX77A / BUX78A

- High Power
- Hermetic TO-66 Metal Package
- Ideally suited for Driver Circuits, Switching and Amplifier Applications
- Screening Options Available



### ABSOLUTE MAXIMUM RATINGS

( $T_C = 25^\circ\text{C}$  unless otherwise stated)

		BUX77A NPN	BUX78A PNP
$V_{CBO}$	Collector – Base Voltage	100V	-100V
$V_{CEO}$	Collector – Emitter Voltage	80V	-80V
$V_{EBO}$	Emitter – Base Voltage	6V	-6V
$I_C$	Continuous Collector Current	8A	
$I_B$	Base Current	2A	
$P_D$	Total Power Dissipation at $T_C = 25^\circ\text{C}$ Derate Above $25^\circ\text{C}$	40W 0.23W/ $^\circ\text{C}$	
$T_J$	Junction Temperature Range	-65 to $+200^\circ\text{C}$	
$T_{stg}$	Storage Temperature Range	-65 to $+200^\circ\text{C}$	

### THERMAL PROPERTIES

Symbols	Parameters	Min.	Typ.	Max.	Units
$R_{\theta JC}$	Thermal Resistance, Junction To Case			4.4	$^\circ\text{C/W}$

Semelab Limited reserves the right to change test conditions, parameter limits and package dimensions without notice. Information furnished by Semelab is believed to be both accurate and reliable at the time of going to press. However Semelab assumes no responsibility for any errors or omissions discovered in its use. Semelab encourages customers to verify that datasheets are current before placing orders.

# SILICON PLANAR EPITAXIAL NPN/PNP TRANSISTORS BUX77A / BUX78A

## ELECTRICAL CHARACTERISTICS ( $T_C = 25^\circ\text{C}$ unless otherwise stated)<sup>(1)</sup>

Symbols	Parameters	Test Conditions	Min.	Typ	Max.	Units
$V_{(BR)CEO}^{(2)}$	Collector-Emitter Breakdown Voltage	$I_C = 50\text{mA}$ $I_B = 0$	80			V
$V_{(BR)CES}$	Collector-Emitter Breakdown Voltage	$I_C = 2\text{mA}$ $V_{BE} = 0$	100			
$V_{(BR)EBO}$	Emitter-Base Breakdown Voltage	$I_E = 1.0\text{mA}$ $I_C = 0$	6			
$I_{CEO}$	Collector Cut-Off Current	$V_{CE} = 60\text{V}$ $I_B = 0$			10	$\mu\text{A}$
$I_{CBO}$	Collector Cut-Off Current	$V_{CB} = 80\text{V}$ $I_E = 0$			0.5	
		$T_C = 150^\circ\text{C}$			150	
$I_{EBO}$	Emitter Cut-Off Current	$V_{EB} = 4\text{V}$ $I_C = 0$			0.5	
$h_{FE}^{(2)}$	Forward-current transfer ratio	$I_C = 0.5\text{A}$ $V_{CE} = 5\text{V}$	50			
		$I_C = 2\text{A}$ $V_{CE} = 5\text{V}$	50		250	
		$I_C = 5\text{A}$ $V_{CE} = 5\text{V}$	30			
		$I_C = 1.0\text{A}$ $V_{CE} = 5\text{V}$ $T_C = -40^\circ\text{C}$	25			
$V_{CE(sat)}^{(2)}$	Collector-Emitter Saturation Voltage	$I_C = 5\text{A}$ $I_B = 0.5\text{A}$			1.0	V
$V_{BE(sat)}^{(2)}$	Base-Emitter Saturation Voltage	$I_C = 5\text{A}$ $I_B = 0.5\text{A}$			1.3	

## DYNAMIC CHARACTERISTICS

$ h_{fel} $	Small signal forward-current transfer ratio	$I_C = 0.5\text{A}$ $V_{CE} = 5\text{V}$ $f = 20\text{MHz}$	1.5			
$t_{on}$	Turn-On Time	$I_C = 5\text{A}$ $V_{CC} = 40\text{V}$ $I_{B1} = 0.5\text{A}$		0.3	0.4	$\mu\text{s}$
$t_{off}$	Turn-Off Time	$I_C = 5\text{A}$ $V_{CC} = 40\text{V}$ $I_{B1} = -I_{B2} = 0.5\text{A}$		1.1	2.5	

### Notes

- (1) For PNP (BUX78A) device, voltage and current values are negative  
(2) Pulse Width  $\leq 300\mu\text{s}$ ,  $\delta \leq 2\%$

# SILICON PLANAR EPITAXIAL NPN/PNP TRANSISTORS BUX77A / BUX78A

## MECHANICAL DATA

Dimensions in mm (inches)

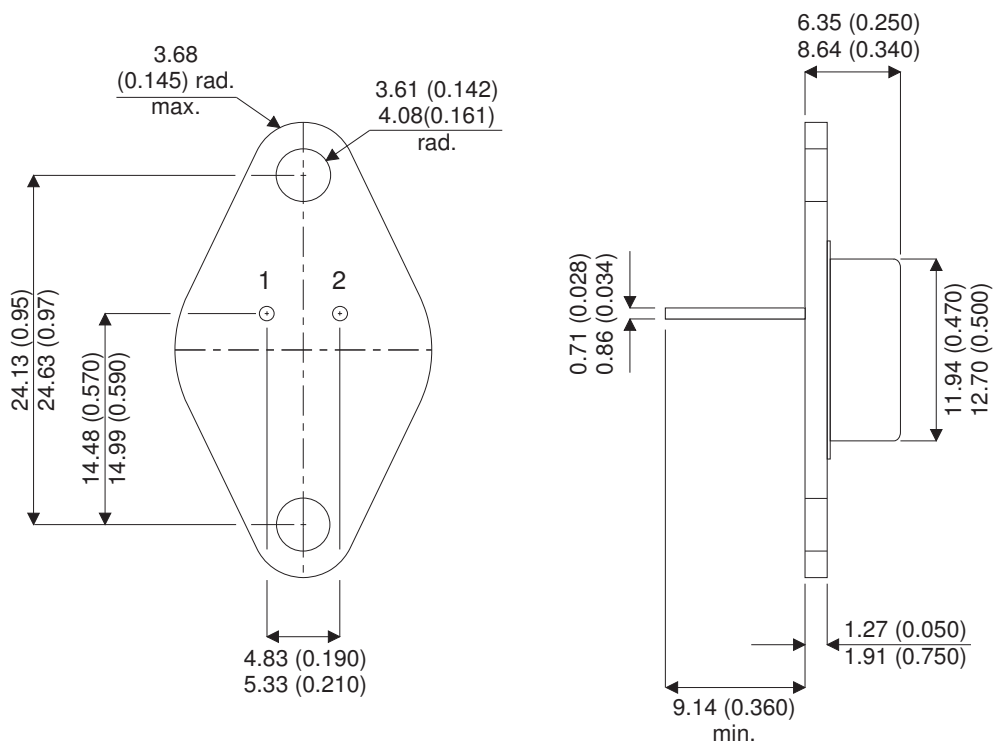

## TO66 (TO-213AA)

Pin 1 - Base

Pin 2 - Emitter

Case - Collector