

MECHANICAL DATA
Dimensions in mm

POWER TRANSISTORS
PNP SILICON

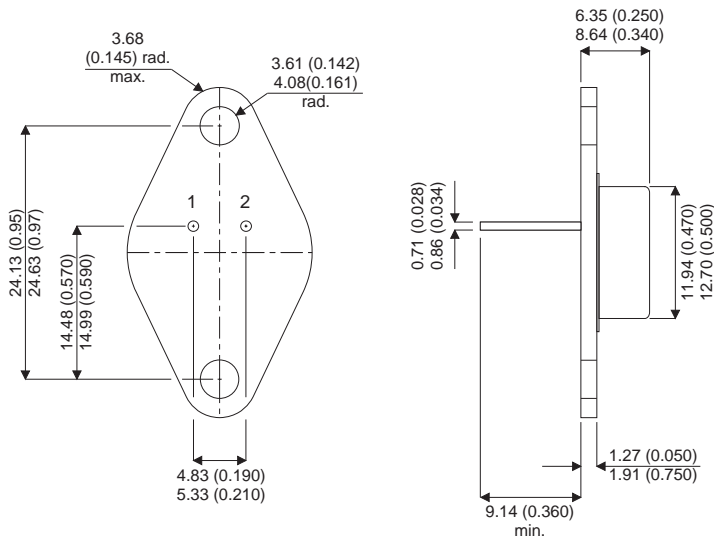

FEATURES

- Hermetically Package.
- Low Saturation Voltage
- High Gain

TO66 Package (TO-213AA)

Complementary to NPN 2N3740

Pin 1 = Base Pin 2 = Emitter Case = Collector

ABSOLUTE MAXIMUM RATINGS ($T_{case} = 25^{\circ}C$ unless otherwise stated)

V_{CBO}	Collector – Base Voltage	80V
V_{CEO}	Collector – Emitter Voltage ($I_B = 0$)	80V
V_{EBO}	Emitter – Base Voltage ($I_C = 0$)	7V
I_C	Collector Current	4A
$I_{C(PK)}$	Peak Collector Current	10A
I_B	Base Current	2A
P_D	Total Device Dissipation at $T_{case} = 25^{\circ}C$ Derate $25^{\circ}C$	25W 0.143W/ $^{\circ}C$
T_{stg}	Operating and Storage Temperature Range	-65 to $200^{\circ}C$

Semelab Plc reserves the right to change test conditions, parameter limits and package dimensions without notice. Information furnished by Semelab is believed to be both accurate and reliable at the time of going to press. However Semelab assumes no responsibility for any errors or omissions discovered in its use. Semelab encourages customers to verify that datasheets are current before placing orders.

ELECTRICAL CHARACTERISTICS ($T_{\text{case}} = 25^{\circ}\text{C}$ unless otherwise stated)

Parameter	Test Conditions	Min.	Typ.	Max.	Unit
ELECTRICAL CHARACTERISTICS					
$V_{\text{CEO(sus)*}}$	Collector – Emitter Sustaining Voltage	$I_{\text{C}} = 100\text{mA}$ $I_{\text{B}} = 0$	80		V
I_{CBO}	Collector Base Cut-Off Current	$V_{\text{CB}} = 80\text{V}$ $I_{\text{E}} = 0$		100	μA
I_{CEO}	Collector Emitter Cut-Off Current	$V_{\text{CE}} = 60\text{V}$ $I_{\text{B}} = 0$		1.0	mA
I_{CEX}	Collector Cut-Off Current	$V_{\text{CE}} = 80\text{V}$ $V_{\text{BE(OFF)}} = 1.5\text{V}$		100	μA
		$V_{\text{CE}} = 60\text{V}$ $V_{\text{BE(OFF)}} = 1.5\text{V}$ $T_{\text{C}} = 150^{\circ}\text{C}$		1	mA
I_{EBO}	Emitter Base Cut-Off Current	$V_{\text{EB}} = 7\text{V}$		0.5	mA
$h_{\text{FE}*}$	DC Current Gain	$I_{\text{C}} = 100\text{mA}$ $V_{\text{CE}} = 1\text{V}$	40		—
		$I_{\text{C}} = 250\text{mA}$ $V_{\text{CE}} = 1\text{V}$	30	180	
		$I_{\text{C}} = 500\text{mA}$ $V_{\text{CE}} = 1\text{V}$	20		
		$I_{\text{C}} = 1\text{A}$ $V_{\text{CE}} = 1\text{V}$	10		
$V_{\text{CE(sat)*}}$	Collector – Emitter Saturation Voltage	$I_{\text{C}} = 1\text{A}$ $I_{\text{B}} = 125\text{mA}$		0.6	V
$V_{\text{BE}*}$	Base – Emitter Saturation Voltage	$I_{\text{C}} = 250\text{mA}$ $I_{\text{B}} = 1\text{V}$		1.0	
DYNAMIC CHARACTERISTICS					
f_{t}	Transition Frequency	$I_{\text{C}} = 100\text{mA}$ $V_{\text{CE}} = 10\text{V}$ $f = 1\text{MHz}$	3		MHz
			4		
C_{ob}	Output Capacitance	$V_{\text{CB}} = 10\text{V}$ $I_{\text{C}} = 0$ $f = 100\text{KHz}$		100	pF
h_{fe}	Small Signal Current Gain	$I_{\text{C}} = 50\text{mA}$ $V_{\text{CE}} = 10\text{V}$ $f = 1\text{KHz}$	25		—

* Pulse Width $\leq 300\mu\text{s}$, Duty Cycle $< 2\%$