

# SILICON PLANAR EPITAXIAL PNP TRANSISTOR

## 2N2904

- Low Power
- Hermetic TO-39 Metal package.
- Ideally suited for High Speed Switching and General Purpose Applications
- Screening Options Available

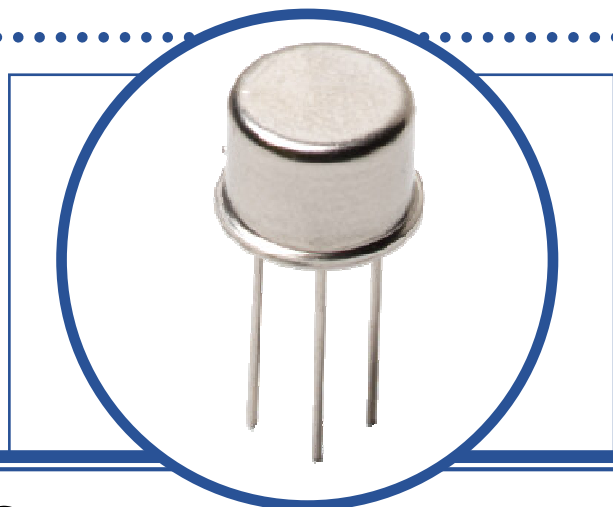

### ABSOLUTE MAXIMUM RATINGS (T<sub>A</sub> = 25°C unless otherwise stated)

V <sub>CBO</sub>	Collector – Base Voltage	-60V
V <sub>CEO</sub>	Collector – Emitter Voltage	-40V
V <sub>EBO</sub>	Emitter – Base Voltage	-5V
I <sub>C</sub>	Continuous Collector Current	-600mA
P <sub>D</sub>	Total Power Dissipation at T <sub>A</sub> = 25°C	600mW
	Derate Above 25°C	3.43mW/°C
P <sub>D</sub>	Total Power Dissipation at T <sub>C</sub> = 25°C	3W
	Derate Above 25°C	17.2mW/°C
T <sub>J</sub>	Junction Temperature Range	-65 to +200°C
T <sub>stg</sub>	Storage Temperature Range	-65 to +200°C

### THERMAL PROPERTIES

Symbols	Parameters	Min.	Typ.	Max.	Units
R <sub>θJA</sub>	Thermal Resistance, Junction To Ambient			291.7	°C/W
R <sub>θJC</sub>	Thermal Resistance, Junction To Case			58.3	°C/W

Semelab Limited reserves the right to change test conditions, parameter limits and package dimensions without notice. Information furnished by Semelab is believed to be both accurate and reliable at the time of going to press. However Semelab assumes no responsibility for any errors or omissions discovered in its use. Semelab encourages customers to verify that datasheets are current before placing orders.



# SILICON PLANAR EPITAXIAL PNP TRANSISTOR 2N2904

## ELECTRICAL CHARACTERISTICS ( $T_A = 25^\circ\text{C}$ unless otherwise stated)

Symbols	Parameters	Test Conditions	Min.	Typ	Max.	Units
$V_{(BR)CEO}^{(1)}$	Collector-Emitter Breakdown Voltage	$I_C = -10\text{mA}$ $I_B = 0$	-40			V
$V_{(BR)CBO}$	Collector-Base Breakdown Voltage	$I_C = -10\mu\text{A}$ $I_E = 0$	-60			
$V_{(BR)EBO}$	Emitter-Base Breakdown Voltage	$I_E = -10\mu\text{A}$ $I_C = 0$	-5			
$I_{CEX}$	Collector Cut-Off Current	$V_{CE} = -30\text{V}$ $V_{BE} = -0.5\text{V}$			-50	nA
$I_{CBO}$	Collector Cut-Off Current	$V_{CB} = -50\text{V}$ $I_E = 0$			-0.02	$\mu\text{A}$
		$T_A = 150^\circ\text{C}$			-20	
$V_{CE(sat)}^{(1)}$	Collector-Emitter Saturation Voltage	$I_C = -150\text{mA}$ $I_B = -15\text{mA}$			-0.4	V
		$I_C = -500\text{mA}$ $I_B = -50\text{mA}$			-1.6	
$V_{BE(sat)}^{(1)}$	Base-Emitter Saturation Voltage	$I_C = -150\text{mA}$ $I_B = -15\text{mA}$			-1.3	
		$I_C = -500\text{mA}$ $I_B = -50\text{mA}$			-2.6	
$h_{FE}^{(1)}$	Forward-current transfer ratio	$I_C = -0.1\text{mA}$ $V_{CE} = -10\text{V}$	20			
		$I_C = -1.0\text{mA}$ $V_{CE} = -10\text{V}$	25			
		$I_C = -10\text{mA}$ $V_{CE} = -10\text{V}$	35			
		$I_C = -150\text{mA}$ $V_{CE} = -10\text{V}$	40	120		
		$I_C = -500\text{mA}$ $V_{CE} = -10\text{V}$	20			

## DYNAMIC CHARACTERISTICS

$f_T$	Transition Frequency	$I_C = -50\text{mA}$ $V_{CE} = -20\text{V}$ $f = 100\text{MHz}$	170			MHz
$C_{obo}$	Output Capacitance	$V_{CB} = -10\text{V}$ $I_E = 0$ $f = 1.0\text{MHz}$			8	$\text{pF}$
$C_{ibo}$	Input Capacitance	$V_{EB} = -2\text{V}$ $I_C = 0$ $f = 1.0\text{MHz}$			30	
$t_{on}$	Turn-On Time	$I_C = -150\text{mA}$ $V_{CC} = -30\text{V}$ $I_{B1} = -15\text{mA}$			45	ns
$t_{off}$	Turn-Off Time	$I_C = -150\text{mA}$ $V_{CC} = -30\text{V}$ $I_{B1} = -I_{B2} = -15\text{mA}$			300	

### Notes

(1) Pulse Width  $\leq 300\mu\text{s}$ ,  $\delta \leq 2\%$

# SILICON PLANAR EPITAXIAL PNP TRANSISTOR 2N2904

## MECHANICAL DATA

Dimensions in mm (inches)

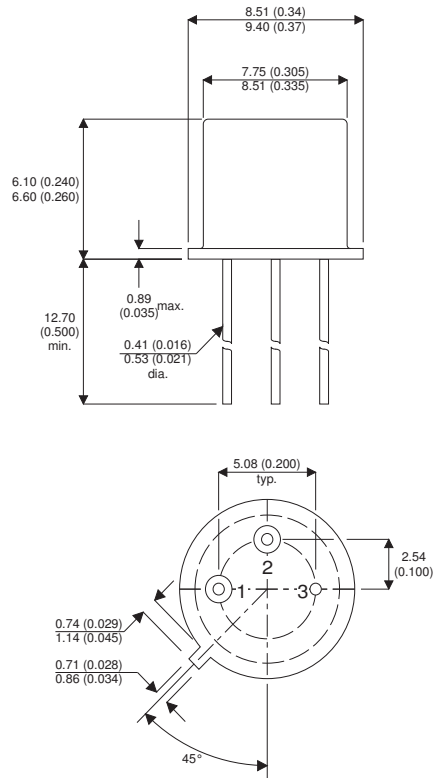

### TO-39 (TO-205AD) METAL PACKAGE Underside View

Pin 1 - Emitter

Pin 2 - Base

Pin 3 - Collector