

# SILICON NPN TRANSISTOR

## 2N2891

- $V_{(BR)CEO} = 80V$  (Min).
- Hermetic TO-39 Metal Package.
- Ideally Suited For Low Frequency Large Signal Applications (High Voltage).
- Screening Options Available

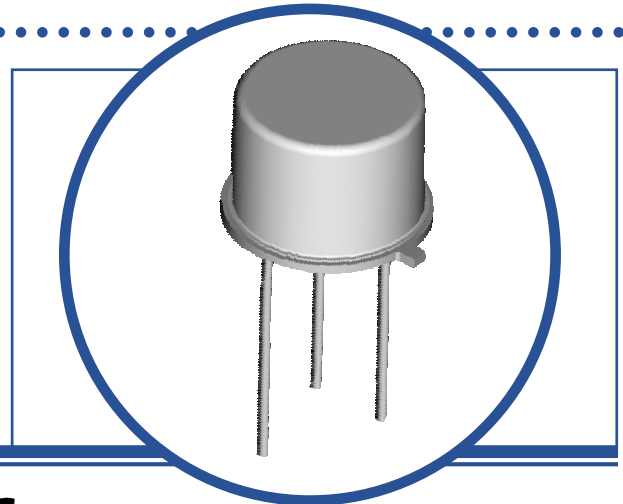

### ABSOLUTE MAXIMUM RATINGS ( $T_A = 25^\circ C$ unless otherwise stated)

$V_{CBO}$	Collector – Base Voltage		100V
$V_{CEO}$	Collector – Emitter Voltage		80V
$V_{EBO}$	Emitter – Base Voltage		5V
$I_C$	Continuous Collector Current		3A
$I_{CM}$	Peak Collector Current		5A
$I_B$	Base Current		0.5A
$P_D$	Total Power Dissipation at	$T_A = 25^\circ C$	0.8W
		Derate Above $25^\circ C$	4.57mW/ $^\circ C$
$P_D$	Total Power Dissipation at	$T_C = 25^\circ C$	5W
		Derate Above $25^\circ C$	28.6mW/ $^\circ C$
$T_J$	Junction Temperature Range		-65 to +200 $^\circ C$
$T_{stg}$	Storage Temperature Range		-65 to +200 $^\circ C$

### THERMAL PROPERTIES

Symbols	Parameters	Max.	Units
$R_{\theta JA}$	Thermal Resistance, Junction To Ambient	218.75	$^\circ C/W$
$R_{\theta JC}$	Thermal Resistance, Junction To Case	35	$^\circ C/W$

Semelab Limited reserves the right to change test conditions, parameter limits and package dimensions without notice. Information furnished by Semelab is believed to be both accurate and reliable at the time of going to press. However Semelab assumes no responsibility for any errors or omissions discovered in its use. Semelab encourages customers to verify that datasheets are current before placing orders.

# SILICON NPN TRANSISTOR 2N2891

## ELECTRICAL CHARACTERISTICS ( $T_A = 25^\circ\text{C}$ unless otherwise stated)

Symbols	Parameters	Test Conditions	Min.	Typ	Max.	Units
$V_{(BR)CEO}^{(1)}$	Collector-Emitter Breakdown Voltage	$I_C = 10\text{mA}$ $I_B = 0$	80			V
$V_{(BR)CBO}^{(1)}$	Collector-Base Breakdown Voltage	$I_C = 0.1\text{mA}$ $I_E = 0$	100			
$I_{CEO}$	Collector Cut-Off Current	$V_{CE} = 60\text{V}$ $I_B = 0$			50	$\mu\text{A}$
$I_{CEX}$	Collector Cut-Off Current	$V_{CE} = 60\text{V}$ $V_{BE} = -2\text{V}$ $T_A = 150^\circ\text{C}$			0.1	
		$V_{CE} = 90\text{V}$ $V_{BE} = -2\text{V}$			100	
$I_{EBO}$	Emitter Cut-Off Current	$V_{EB} = 5\text{V}$ $I_C = 0$			10	
$h_{FE}^{(1)}$	Forward-current transfer ratio	$I_C = 100\text{mA}$ $V_{CE} = 2\text{V}$	35			
		$I_C = 1.0\text{A}$ $V_{CE} = 2\text{V}$	50		150	
		$I_C = 2\text{A}$ $V_{CE} = 5\text{V}$	40			
$V_{CE(sat)}^{(1)}$	Collector-Emitter Saturation Voltage	$I_C = 1.0\text{A}$ $I_B = 100\text{mA}$			0.5	V
		$I_C = 2\text{A}$ $I_B = 200\text{mA}$			0.75	
$V_{BE(sat)}^{(1)}$	Base-Emitter Saturation Voltage	$I_C = 1.0\text{A}$ $I_B = 100\text{mA}$			1.2	
		$I_C = 2\text{A}$ $I_B = 200\text{mA}$			1.3	

## DYNAMIC CHARACTERISTICS

$h_{fe}$	Small-Signal Current Gain	$I_C = 50\text{mA}$ $V_{CE} = 10\text{V}$ $f = 1.0\text{KHz}$	50		350	
$f_T$	Transition Frequency	$I_C = 200\text{mA}$ $V_{CE} = 10\text{V}$ $f = 20\text{MHz}$	30			MHz
$C_{obo}$	Output Capacitance	$V_{CB} = 10\text{V}$ $I_E = 0$ $f = 1.0\text{MHz}$		70	100	$\mu\text{F}$
$t_{on}$	Turn-On Time	$I_C = 1.0\text{A}$ $V_{CC} = 20\text{V}$ $I_{B1} = 50\text{mA}$			0.3	$\mu\text{s}$
$t_{off}$	Turn-Off Time	$I_C = 1.0\text{A}$ $V_{CC} = 20\text{V}$ $I_{B1} = 50\text{mA}$ $I_{B2} = -50\text{mA}$			1.5	

### Notes

(1) Pulse Width  $\leq 380\mu\text{s}$ ,  $\delta \leq 2\%$

# SILICON NPN TRANSISTOR 2N2891

## MECHANICAL DATA

Dimensions in mm (inches)

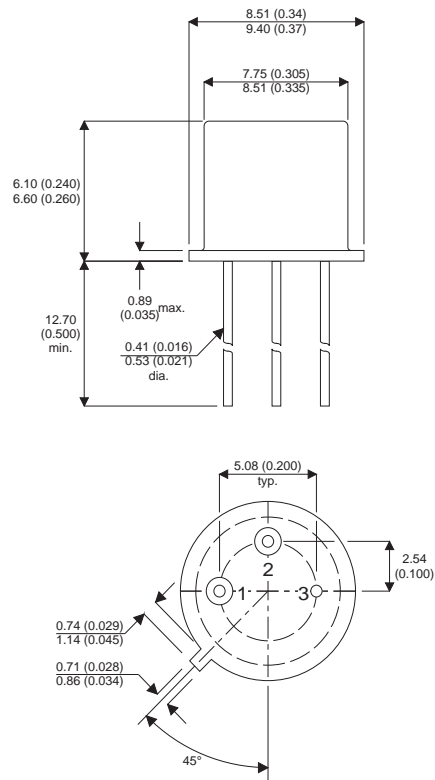

### TO-39 (TO-205AD) METAL PACKAGE Underside View

Pin 1 - Emitter

Pin 2 - Base

Pin 3 - Collector