

# SILICON PLANAR NPN TRANSISTOR

## 2N1893

- High Speed Switching
- Hermetic TO-39 Metal package.
- Ideally suited for Small Signal General Purpose and Switching Applications
- Screening Options Available

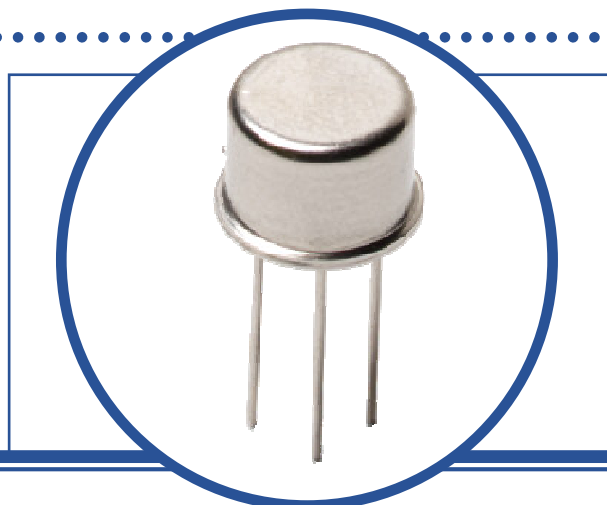

### ABSOLUTE MAXIMUM RATINGS (T<sub>A</sub> = 25°C unless otherwise stated)

V <sub>CBO</sub>	Collector – Base Voltage	120V
V <sub>CEO</sub>	Collector – Emitter Voltage	80V
V <sub>EBO</sub>	Emitter – Base Voltage	7V
I <sub>C</sub>	Continuous Collector Current	500mA
P <sub>D</sub>	Total Power Dissipation at T <sub>A</sub> = 25°C	800mW
	Derate Above 25°C	5.7mW/°C
P <sub>D</sub>	Total Power Dissipation at T <sub>C</sub> = 25°C	3W
	Derate Above 25°C	17.2mW/°C
T <sub>J</sub>	Junction Temperature Range	-65 to +200°C
T <sub>stg</sub>	Storage Temperature Range	-65 to +200°C

### THERMAL PROPERTIES

Symbols	Parameters	Min.	Typ.	Max.	Units
R <sub>θJA</sub>	Thermal Resistance, Junction To Ambient			175	°C/W
R <sub>θJC</sub>	Thermal Resistance, Junction To Case			50	°C/W

Semelab Limited reserves the right to change test conditions, parameter limits and package dimensions without notice. Information furnished by Semelab is believed to be both accurate and reliable at the time of going to press. However Semelab assumes no responsibility for any errors or omissions discovered in its use. Semelab encourages customers to verify that datasheets are current before placing orders.



# SILICON PLANAR PNP TRANSISTOR 2N1893

## ELECTRICAL CHARACTERISTICS ( $T_A = 25^\circ\text{C}$ unless otherwise stated)

Symbols	Parameters	Test Conditions	Min.	Typ	Max.	Units
$V_{(BR)CEO}^{(1)}$	Collector-Emitter Breakdown Voltage	$I_C = 30\text{mA}$ $I_B = 0$	80			V
$V_{(BR)CER}$	Collector-Emitter Breakdown Voltage	$I_C = 10\text{mA}$ $I_E = 0$ $R_{BE} = 10\Omega$	100			
$I_{CBO}$	Collector-Base Cut-Off Current	$V_{CB} = 120\text{V}$ $I_E = 0$			100	$\mu\text{A}$
		$V_{CB} = 90\text{V}$ $I_E = 0$			10	nA
		$T_A = 150^\circ\text{C}$			15	$\mu\text{A}$
$I_{EBO}$	Emitter Cut-Off Current	$V_{EB} = 7\text{V}$ $I_C = 0$			100	nA
		$V_{EB} = 5\text{V}$ $I_C = 0$			10	nA
$V_{CE(sat)}^{(1)}$	Collector-Emitter Saturation Voltage	$I_C = 150\text{mA}$ $I_B = 15\text{mA}$			5	V
$V_{BE(sat)}^{(1)}$	Base-Emitter Saturation Voltage	$I_C = 150\text{mA}$ $I_B = 15\text{mA}$			1.3	
$h_{FE}^{(1)}$	Forward-current transfer ratio	$I_C = 1\text{mA}$ $V_{CE} = 10\text{V}$	20			
		$I_C = 10\text{mA}$ $V_{CE} = 10\text{V}$	35			
		$T_A = -55^\circ\text{C}$	20			
		$I_C = 150\text{mA}$ $V_{CE} = 10\text{V}$	40		120	

## DYNAMIC CHARACTERISTICS

$ h_{fe} $	Small signal forward-current transfer ratio	$I_C = 50\text{mA}$ $V_{CE} = 10\text{V}$ $f = 20\text{MHz}$	3.0		10	
$h_{fe}$	Forward Current Transfer Ratio	$V_{CE} = 5\text{V}$ $I_C = 1\text{mA}$ $f = 1.0\text{kHz}$	35		100	
		$V_{CE} = 10\text{V}$ $I_C = 5\text{mA}$ $f = 1.0\text{kHz}$	45		150	
$C_{obo}$	Output Capacitance	$V_{CB} = 10\text{V}$ $I_E = 0$	2		15	$\mu\text{F}$
$h_{ie}^{(2)}$	Short Circuit Input Impedance	$V_{CB} = 10\text{V}$ $I_C = 5\text{mA}$	4		8	$\Omega$
$h_{oe}^{(2)}$	Short Circuit Output Admittance	$V_{CB} = 10\text{V}$ $I_C = 5\text{mA}$			0.5	$\mu\Omega$
$h_{re}^{(2)}$	Open Circuit Reverse Voltage Transfer Ratio	$V_{CB} = 10\text{V}$ $I_C = 5\text{mA}$			1.5	$\times 10^{-4}$

### Notes

- (1) Pulse Width  $\leq 380\mu\text{s}$ ,  $\delta \leq 2\%$   
(2) Parameter guaranteed by design, not part of a production test.

# SILICON PLANAR PNP TRANSISTOR 2N1893

## MECHANICAL DATA

Dimensions in mm (inches)

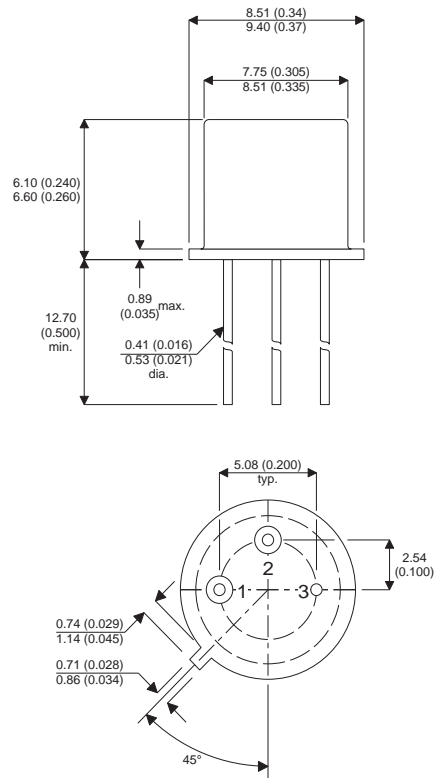

### TO-39 (TO-205AD) METAL PACKAGE Underside View

Pin 1 - Emitter

Pin 2 - Base

Pin 3 - Collector