

Pin 1 – ADJ.  
 Pin 2 –  $V_{OUT}$   
 Case –  $V_{IN}$

**Q Package – TO-254**

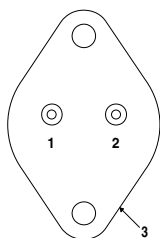

Pin 1 – ADJ.  
 Pin 2 –  $V_{IN}$   
 Case –  $V_{OUT}$

**K Package – TO-3**

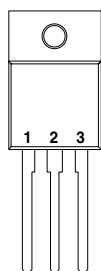

Pin 1 – ADJ.  
 Pin 2 –  $V_{OUT}$   
 Pin 3 –  $V_{IN}$   
 Case –  $V_{OUT}$

**V Package – TO-218**

## 5 AMP POSITIVE ADJUSTABLE VOLTAGE REGULATOR

### FEATURES

- **OUTPUT VOLTAGE RANGE OF 1.25 TO 35V**
- **1% OUTPUT VOLTAGE TOLERANCE (-A VERSIONS)**
- **0.3% LOAD REGULATION**
- **0.01%/V LINE REGULATION**
- **COMPLETE SERIES OF PROTECTIONS:**
  - **CURRENT LIMITING**
  - **THERMAL SHUTDOWN**
  - **SOA CONTROL**

### Order Information

Part Number	K-Pack (TO-3)	V-Pack (TO-218)	Q-Pack (TO-254)	Temp. Range	Note:
IP138A	4		4	-55 to +150°C	To order, add the package identifier to the part number.  eg. IP138AQ
IP138	4		4	"	
LM138	4		4	"	
IP338A	4	4		0 to 125°C	
IP338	4	4		"	
LM338	4	4		"	

### ABSOLUTE MAXIMUM RATINGS ( $T_{case} = 25^{\circ}C$ unless otherwise stated)

$V_{I-O}$	Input - Output Differential Voltage	35V
$P_D$	Power Dissipation	Internally limited
$T_J$	Operating Junction Temperature Range	See Table Above
$T_{STG}$	Storage Temperature	-65 to 150°C
$T_L$	Lead Temperature (Soldering, 10 sec.)	300°C

Parameter	Test Conditions	IP138A			LM138 IP138			Units	
		Min.	Typ.	Max.	Min.	Typ.	Max.		
$V_{REF}$ Reference Voltage	$I_{OUT} = 10\text{mA}$	1.238	1.25	1.262				V	
	$I_{OUT} = 10\text{mA to } 5\text{A}$ $V_{IN} - V_{OUT} = 3\text{V to } 35\text{V}$ $P \leq 50\text{W}$ $T_J = -55 \text{ to } +150^\circ\text{C}$	1.225	1.250	1.270	1.190	1.240	1.290	V	
$\frac{\Delta V_{OUT}}{\Delta V_{IN}}$ Line Regulation 1	$V_{IN} - V_{OUT} = 3\text{V to } 35\text{V}$ $T_J = -55 \text{ to } +150^\circ\text{C}$		0.005	0.010		0.005	0.010	% / V	
			0.020	0.040		0.020	0.040		
$\frac{\Delta V_{OUT}}{\Delta I_{OUT}}$ Load Regulation 1	$I_{OUT} = 10\text{mA to } 5\text{A}$ $V_{OUT} \leq 5\text{V}$		5	15		5	15	mV	
			0.1	0.3		0.1	0.3	%	
	$I_{OUT} = 10\text{mA to } 5\text{A}$ $T_J = -55 \text{ to } +150^\circ\text{C}$	$V_{OUT} \leq 5\text{V}$		20	30		20	30	mV
		$V_{OUT} \geq 5\text{V}$		0.3	0.6		0.3	0.6	%
Thermal Regulation	$t_p = 20\text{ms}$		0.002	0.010		0.002	0.010	%/W	
Ripple Rejection	$V_{OUT} = 10\text{V}$ $f = 120\text{Hz}$	$C_{ADJ} = 0$ $T_J = -55 \text{ to } +150^\circ\text{C}$		60		60		dB	
		$C_{ADJ} = 10\mu\text{F}$ $T_J = -55 \text{ to } +150^\circ\text{C}$	60	75		60	75	dB	
$I_{ADJ}$ Adjust Pin Current	$T_J = -55 \text{ to } +150^\circ\text{C}$		45	100		45	100	$\mu\text{A}$	
$\Delta I_{ADJ}$ Adjust Pin Current Change	$I_{OUT} = 10\text{mA to } 5\text{A}$ $V_{IN} - V_{OUT} = 3\text{V to } 35\text{V}$ $T_J = -55 \text{ to } +150^\circ\text{C}$		0.2	5		0.2	5	$\mu\text{A}$	
$I_{MIN}$ Minimum Load Current	$V_{IN} - V_{OUT} = 35\text{V}$ $T_J = -55 \text{ to } +150^\circ\text{C}$		3.5	5		3.5	5	mA	
$I_{SC}$ Current Limit	$V_{IN} - V_{OUT} \leq 10\text{V}$ $T_J = -55 \text{ to } +150^\circ\text{C}$	DC	5	8	5	8		A	
		0.5ms Peak	7	12	7	12		A	
	$V_{IN} - V_{OUT} = 30\text{V}$	0.25	1		1		A		
$\frac{\Delta V_{OUT}}{\Delta \text{TEMP}}$ Temperature Stability	$T_J = -55 \text{ to } +150^\circ\text{C}$		1	2		1		%	
$\frac{\Delta V_{OUT}}{\Delta \text{TIME}}$ Long Term Stability	$T_A = 125^\circ\text{C}$ $t = 1000 \text{ Hrs}$		0.3	1		0.3	1	%	
$e_n$ RMS Output Noise (% of $V_{OUT}$ )	$f = 10 \text{ Hz to } 10 \text{ kHz}$		0.001			0.001		%	
$R_{\theta JC}$ Thermal Resistance Junction to Case	K Package (TO-3)			1			1	$^\circ\text{C/W}$	

1) Regulation is measured at constant junction temperature, using pulse testing at a low duty cycle. Changes in output voltage due to heating effects are covered under thermal regulation specifications. Load regulation is measured from the bottom of the package for the TO-3 package.

2) Test Conditions unless otherwise stated:  $V_{IN} - V_{OUT} = 5\text{V}$ ,  $T_J = 25^\circ\text{C}$ ,  $I_{OUT} = 2.5\text{A}$ .  
 Although power dissipation is internally limited, these specifications apply for dissipations of 50W and  $I_{MAX} = 5\text{A}$ .

Parameter	Test Conditions	IP338A			LM338 IP338			Units
		Min.	Typ.	Max.	Min.	Typ.	Max.	
$V_{REF}$ Reference Voltage	$I_{OUT} = 10mA$	1.238	1.25	1.262				V
	$I_{OUT} = 10mA$ to 5A $V_{IN} - V_{OUT} = 3V$ to 35V $P \leq 50W$ $T_J = 0$ to +125°C	1.225	1.250	1.270	1.190	1.240	1.290	V
$\frac{\Delta V_{OUT}}{\Delta V_{IN}}$ Line Regulation 1	$V_{IN} - V_{OUT} = 3V$ to 35V $T_J = 0$ to +125°C		0.005	0.010		0.005	0.030	% / V
			0.020	0.040		0.020	0.060	
$\frac{\Delta V_{OUT}}{\Delta I_{OUT}}$ Load Regulation 1	$I_{OUT} = 10mA$ to 5A $T_J = 0$ to +125°C	$V_{OUT} \leq 5V$	5	15	5	25	mV	
		$V_{OUT} \geq 5V$	0.1	0.3	0.1	0.5	%	
	$I_{OUT} = 10mA$ to 5A $T_J = 0$ to +125°C	$V_{OUT} \leq 5V$	20	30	20	50	mV	
		$V_{OUT} \geq 5V$	0.3	0.6	0.3	1	%	
Thermal Regulation	$t_p = 20ms$		0.002	0.020		0.002	0.020	%/W
Ripple Rejection	$V_{OUT} = 10V$ $f = 120Hz$	$C_{ADJ} = 0$ $T_J = 0$ to +125°C		60		60		dB
		$C_{ADJ} = 10\mu F$ $T_J = 0$ to +125°C	60	75	60	75		dB
$I_{ADJ}$ Adjust Pin Current	$T_J = 0$ to +125°C		45	100		45	100	$\mu A$
$\Delta I_{ADJ}$ Adjust Pin Current Change	$I_{OUT} = 10mA$ to 5A $V_{IN} - V_{OUT} = 3V$ to 35V $T_J = 0$ to +125°C		0.2	5		0.2	5	$\mu A$
$I_{MIN}$ Minimum Load Current	$V_{IN} - V_{OUT} = 35V$ $T_J = 0$ to +125°C		3.5	10		3.5	10	mA
$I_{SC}$ Current Limit	$V_{IN} - V_{OUT} \leq 10V$ $T_J = 0$ to +125°C	DC	5	8	5	8		A
		0.5ms Peak	6	12	6	12		A
	$V_{IN} - V_{OUT} = 30V$	0.25	1		1		A	
$\frac{\Delta V_{OUT}}{\Delta TEMP}$ Temperature Stability	$T_J = 0$ to +125°C		1	2		1		%
$\frac{\Delta V_{OUT}}{\Delta TIME}$ Long Term Stability	$T_A = 125^\circ C$ $t = 1000$ Hrs		0.3	1		0.3	1	%
$e_n$ RMS Output Noise (% of $V_{OUT}$ )	$f = 10$ Hz to 10 kHz K Package (TO-3)		0.001			0.003		%
$R_{\theta JC}$ Thermal Resistance Junction to Case	V Package (TO-218)			1			1	°C/W
				1			1	

1) Regulation is measured at constant junction temperature, using pulse testing at a low duty cycle. Changes in output voltage due to heating effects are covered under thermal regulation specifications. Load regulation is measured from the bottom of the package for the TO-3 package and at the junction of the wide and narrow portion of the output lead for the TO-218 package.

2) Test Conditions unless otherwise stated:  $V_{IN} - V_{OUT} = 5V$ ,  $T_J = 25^\circ C$ ,  $I_{OUT} = 2.5A$ .  
 Although power dissipation is internally limited, these specifications apply for dissipations of 50W and  $I_{MAX} = 5A$ .

**TYPICAL PERFORMANCE CHARACTERISTICS**

**Load Regulation**

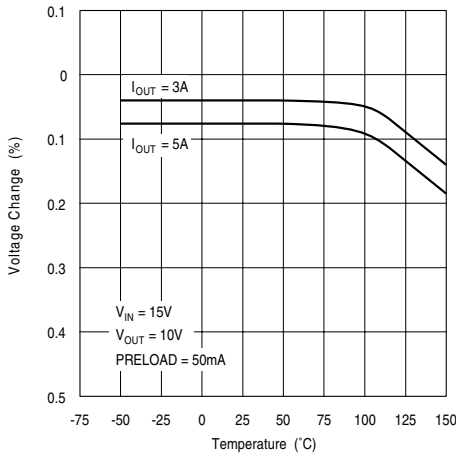

**Output Impedance**

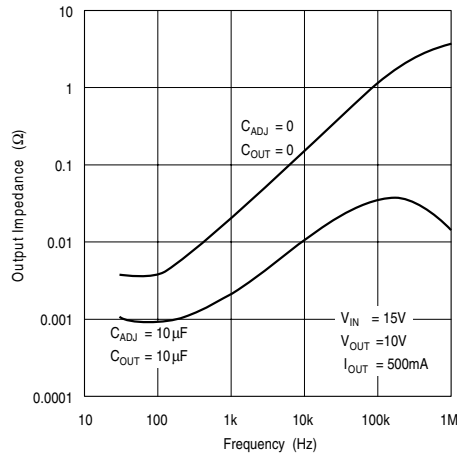

**Adjustment Current**

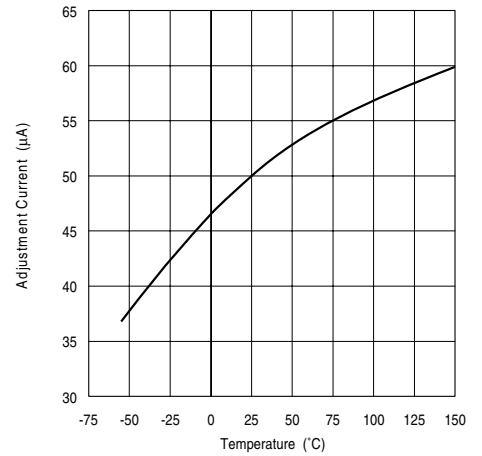

**Dropout Voltage**

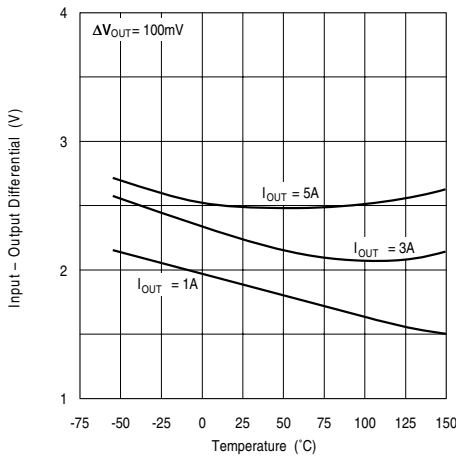

**Temperature Stability**

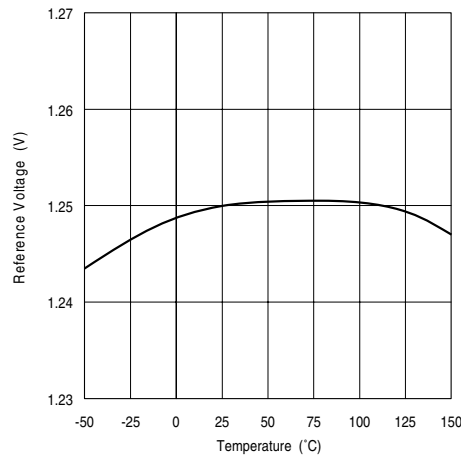

**Minimum Operating Current**

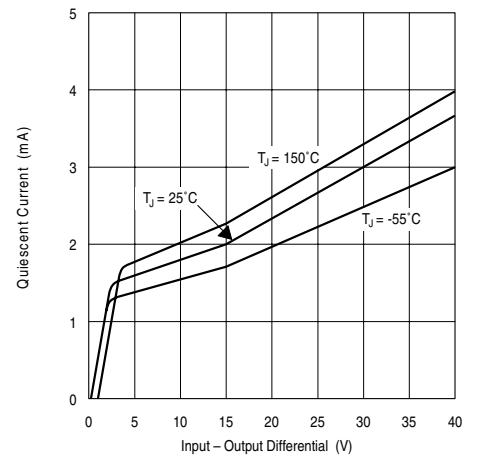

**Ripple Rejection**

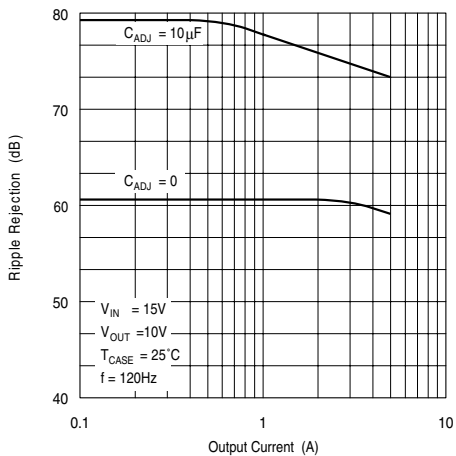

**Ripple Rejection**

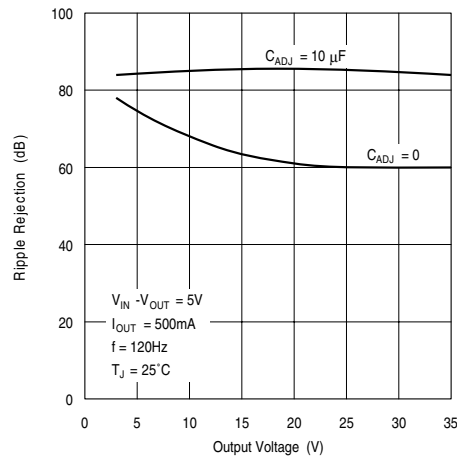

**Ripple Rejection**

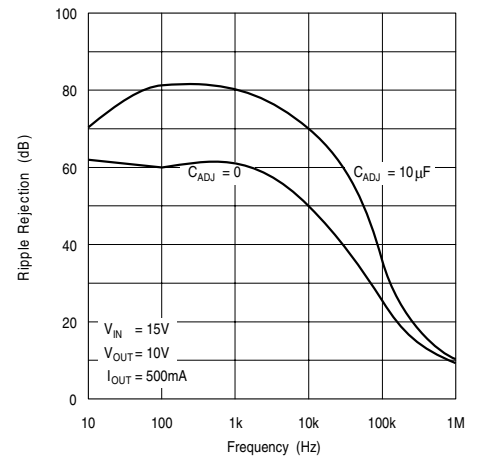

**TYPICAL PERFORMANCE CHARACTERISTICS**

**Current Limit**

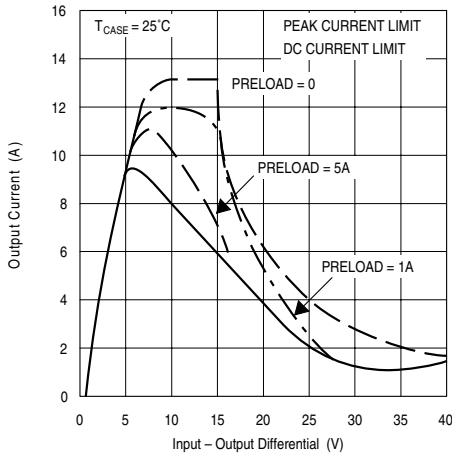

**Current Limit**

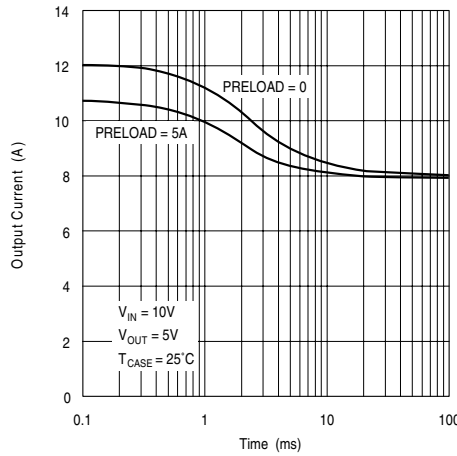

**Current Limit**

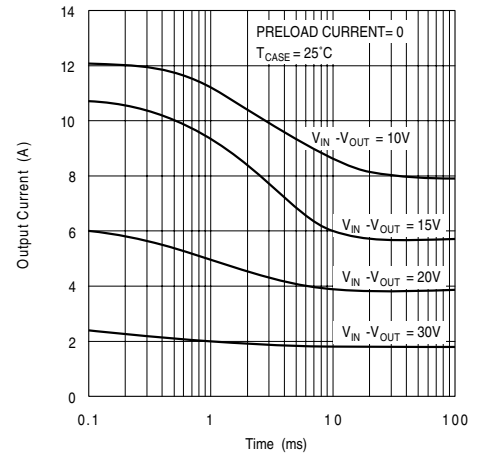

**Line Transient Response**

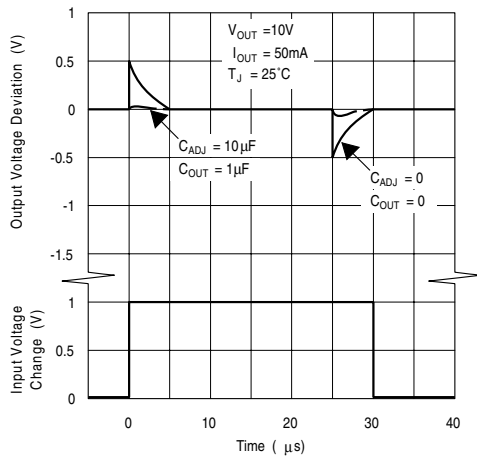

**Load Transient Response**

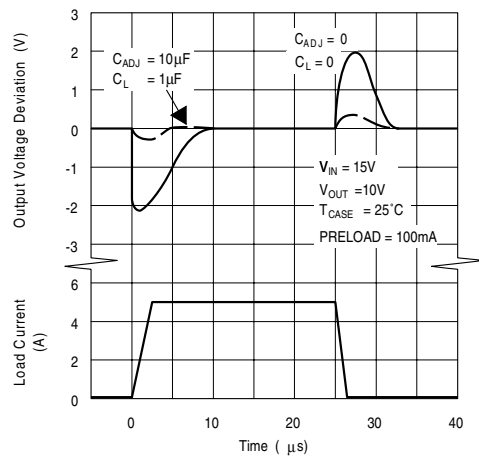

**APPLICATIONS INFORMATION**

**Remote Sensing**

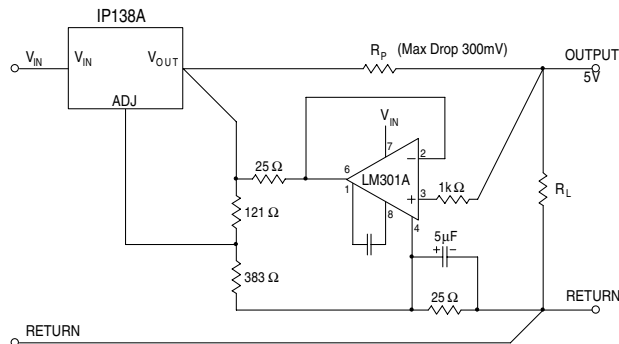

**5V Regulator with Shut Down**

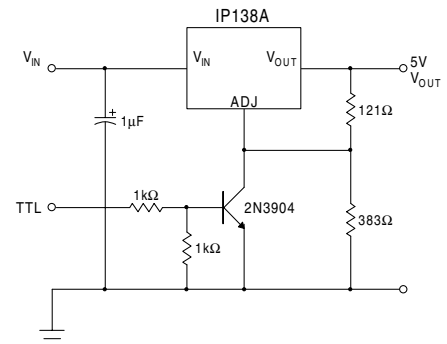

**2816 EEPROM Supply Programmer for Read/Write Control**

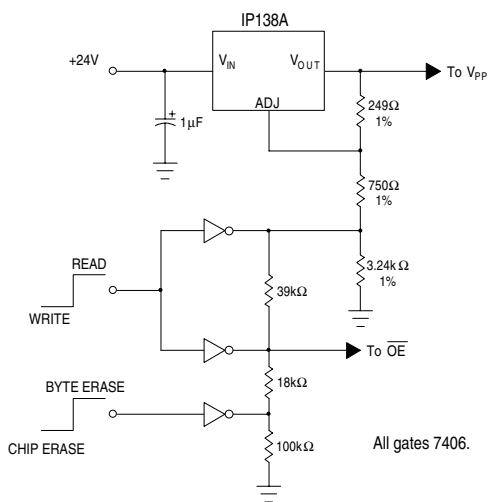

	$\overline{OE}$	$V_{PP}$
READ	0V	5V
WRITE		
BYTE ERASE	5V	21V
CHIP ERASE	12V	21V

**Improving Ripple Rejection**

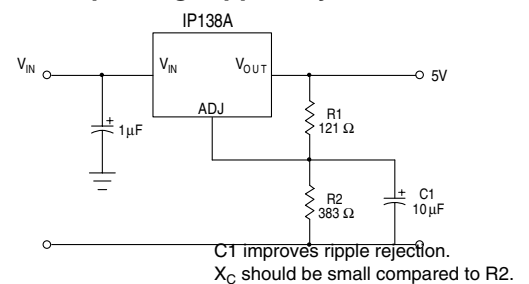

**Temperature Compensated Lead-Acid Battery Charger**

