

**MECHANICAL DATA**

Dimensions in mm(inches)

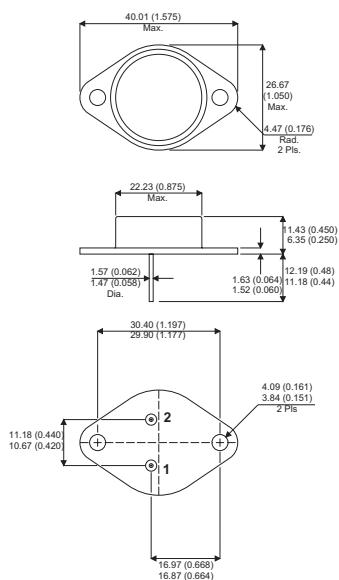

**FAST SWITCHING  
POWER TRANSISTOR**

**FEATURES**

- FAST SWITCHING TIMES
- LOW SWITCHING LOSSES
- LOW BASE CURRENT REQUIREMENTS
- VERY LOW SATURATION VOLTAGE AND HIGH GAIN

**TO-3 (TO-204AA)**

PIN 1 — Base  
PIN 2 — Emitter  
Case is Collector

**ABSOLUTE MAXIMUM RATINGS** ( $T_{case} = 25^{\circ}C$  unless otherwise stated)

$V_{CEV}$	Collector – Emitter Voltage ( $V_{BE} = -1.5V$ )	400V
$V_{CEO}$	Collector – Emitter Voltage ( $I_B = 0$ )	250V
$V_{EBO}$	Emitter – Base Voltage ( $I_C = 0$ )	7V
$I_C$	Collector Current	20A
$I_{CM}$	Peak Collector Current ( $t_p = 10$ ms)	30A
$I_B$	Base Current	4A
$I_{BM}$	Base Peak Current ( $t_p = 10$ ms)	6A
$P_{tot}$	Total Power Dissipation at $T_{case} \leq 25^{\circ}C$	150W
$T_{stg}$	Storage Temperature	-65 to 200°C
$T_j$	Junction Temperature	200°C

Semelab Plc reserves the right to change test conditions, parameter limits and package dimensions without notice. Information furnished by Semelab is believed to be both accurate and reliable at the time of going to press. However Semelab assumes no responsibility for any errors or omissions discovered in its use. Semelab encourages customers to verify that datasheets are current before placing orders.

**ELECTRICAL CHARACTERISTICS** ( $T_{case} = 25^{\circ}C$  unless otherwise stated)

Parameter	Test Conditions	Min.	Typ.	Max.	Unit
$V_{CEO(sus)*}$ Collector - Emitter Sustaining Voltage	$I_C = 200mA$ $L = 25mH$ $I_B = 0$	300			V
$V_{(BR)EBO}$ Emitter – Base Voltage	$I_E = 50mA$	7			
$V_{CE(sat)*}$ Collector Emitter Saturation Voltage	$I_C = 7A$ $I_B = 0.7A$ $T_J = 100^{\circ}C$			0.9 1.9	
$V_{BE(sat)*}$ Base Emitter Saturation Voltage	$I_C = 7A$ $I_B = 0.7A$			1.3	mA
$I_{CER}$ Collector Cut-off Current	$V_{CE} = 400V$ $(R_{BE} = 10\Omega)$			0.5	
$I_{CEV}$ Collector Cut-off Current	$V_{CE} = 400V$ $V_{BE} = -1.5V$ $T_C = 125^{\circ}C$			0.5 2.0	
$I_{EBO}$ Emitter Cut-off Current	$I_C = 0$ $V_{EB} = 5V$			1	

**NOTES**

\* Pulse Test:  $t_p = 300\mu s$ ,  $\delta \leq 2\%$

**THERMAL CHARACTERISTICS**

$R_{\theta JC}$ Thermal Resistance Junction to Case			1.17	$^{\circ}C/W$
---	--	--	------	---------------