

MECHANICAL DATA

Dimensions in mm(inches)

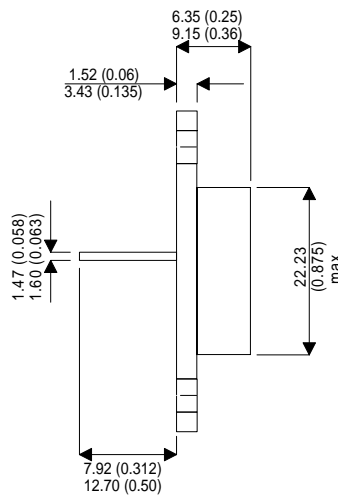
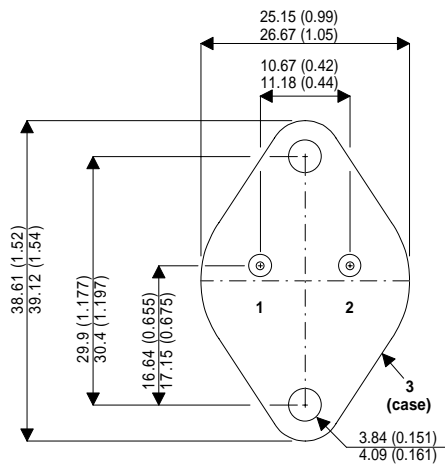

TO3 (TO204AE)

Pin 1 = Base Pin 2 = Emitter Case = Collector

**HIGH CURRENT
NPN SILICON
TRANSISTOR**

FEATURES

- FAST SWITCHING
- HIGH PULSE POWER

APPLICATIONS

- POWER SWITCHING CIRCUITS
- MOTOR CONTROL

ABSOLUTE MAXIMUM RATINGS ($T_{case} = 25^{\circ}C$ unless otherwise stated)

V_{CBO}	Collector – Base Voltage ($I_E = 0V$)	350V
V_{CEO}	Collector – Emitter Voltage ($I_B = 0V$)	250V
V_{EBO}	Collector – Emitter Voltage ($I_C = 0V$)	10V
I_C	Collector Current	60A
I_{CM}	Peak Collector Current ($t_p = 10\text{ ms}$)	80A
I_B	Base Current	16A
P_{tot}	Total Power Dissipation at $T_{case} \leq 25^{\circ}C$	350W
T_{stg}	Storage Temperature	-65°C to +200°C
T_j	Max. Operating Junction Temperature	200°C
$R_{\theta JC}$	Junction to Case Thermal Resistance	0.5°C/W

Semelab Plc reserves the right to change test conditions, parameter limits and package dimensions without notice. Information furnished by Semelab is believed to be both accurate and reliable at the time of going to press. However Semelab assumes no responsibility for any errors or omissions discovered in its use. Semelab encourages customers to verify that datasheets are current before placing orders.

ELECTRICAL CHARACTERISTICS ($T_{case} = 25^{\circ}C$ unless otherwise stated)

Parameter	Test Conditions	Min.	Typ.	Max.	Unit
$V_{(BR)CEO}^*$ Collector - Emitter Breakdown Voltage	$I_C = 200mA$ $I_B = 0$	250			V
$V_{(BR)EBO}$ Emitter – Base Breakdown Voltage	$I_C = 0$ $I_E = 10mA$	10			V
I_{CEO} Collector Emitter Cut-off Current	$V_{CE} = 250V$ $I_B = 0$			1.0	mA
I_{CBO} Collector -Base Cut-off Current	$V_{CE} = 350V$ $I_E = 0$ $T_C = 125^{\circ}C$			0.2	mA
				2	
I_{EBO} Emitter–Base Cut-off Current	$I_C = 0$ $V_{EB} = 7V$			0.2	mA
$V_{CE(sat)}^*$ Collector – Emitter Saturation Voltage	$I_C = 25A$ $I_B = 2A$			1.0	V
	$I_C = 40A$ $I_B = 4A$		0.7	1.5	
$V_{BE(sat)}^*$ Base – Emitter Saturation Voltage	$I_C = 25A$ $I_B = 2A$			1.8	V
	$I_C = 40A$ $I_B = 4A$		1.5	2	
h_{FE} DC Current Gain	$I_C = 5A$ $V_{CE} = 4V$	20		100	—
	$I_C = 40A$ $V_{CE} = 4V$	15			
$I_{S/b}$ Second Breakdown Collector Current	$V_{CE} = 20V$ $t = 1s$	17.5			A
f_t Transition Frequency	$I_C = 1.0A$ $V_{CE} = 5V$ $f = 1MHz$		10	16	MHz
t_{on} Turn–On Time	$I_C = 40A$ $I_B = 4A$ $V_{CC} = 100V$		0.3	1.0	μs
t_f Fall Time	$I_C = 40A$ $I_{B1} = 4A$ $I_{B2} = 4A$ $V_{CC} = 100V$		0.2	0.6	
t_s Storage Time	$I_C = 40A$ $I_{B1} = 4A$ $I_{B2} = 4A$ $V_{CC} = 100V$		1.2	2	

*Pulsed $t_p = 300\mu s$ @ < 1%

Semelab Plc reserves the right to change test conditions, parameter limits and package dimensions without notice. Information furnished by Semelab is believed to be both accurate and reliable at the time of going to press. However Semelab assumes no responsibility for any errors or omissions discovered in its use. Semelab encourages customers to verify that datasheets are current before placing orders.