

Frequency Synthesizer

KSN-807A-119+

50Ω 776 to 807 MHz

The Big Deal

- Low phase noise and spurious
- Robust design and construction
- Small size 0.80" x 0.58" x 0.15"



CASE STYLE: DK801

Product Overview

The KSN-807A-119+ is a Frequency Synthesizer, designed to operate from 776 to 807 MHz for base station application. The KSN-807A-119+ is packaged in a metal case (size of 0.80" x 0.58" x 0.15") to shield against unwanted signals and noise.

Key Features

Feature	Advantages
Low phase noise and spurious: <ul style="list-style-type: none">• Phase Noise: -111 dBc/Hz typ. @ 10 kHz offset• Comparison Spurious: -85 dBc typ.• Reference Spurious: -110 dBc typ.	Low phase noise and spurious improve system EVM (Error Vector Magnitude).
Robust design and construction	To enhance the robustness of KSN-807A-119+, each internal component is secured to the substrate with chip bonder, thereby eliminating the risk of tombstoning during subsequent solder reflow operations by the customer.
Small size, 0.80" x 0.58" x 0.15"	The small size enables the KSN-807A-119+ to be used in compact designs.



ISO 9001 ISO 14001 AS 9100 CERTIFIED



Provides ACTUAL Data Instantly at minicircuits.com

IFIRF MICROWAVE COMPONENTS

For detailed performance specs & shopping online see web site

P.O. Box 350166, Brooklyn, New York 11235-0003 (718) 934-4500 Fax (718) 332-4661

Notes: 1. Performance and quality attributes and conditions not expressly stated in this specification sheet are intended to be excluded and do not form a part of this specification sheet. 2. Electrical specifications and performance data contained herein are based on Mini-Circuit's applicable established test performance criteria and measurement instructions. 3. The parts covered by this specification sheet are subject to Mini-Circuits standard limited warranty and terms and conditions (collectively, "Standard Terms"); Purchasers of this part are entitled to the rights and benefits contained therein. For a full statement of the Standard Terms and the exclusive rights and remedies thereunder, please visit Mini-Circuits' website at www.minicircuits.com/MCLStore/terms.jsp.

50Ω 776 to 807 MHz

Features

- Integrated VCO + PLL
- Low phase noise and spurious
- Robust design and construction
- Low operating voltage (VCC VCO=+5V, VCC PLL=+5V)
- Small size 0.80" x 0.58" x 0.15"

Applications

- Base station

General Description

The KSN-807A-119+ is a Frequency Synthesizer, designed to operate from 776 to 807 MHz for base station application. The KSN-807A-119+ is packaged in a metal case (size of 0.80" x 0.58" x 0.15") to shield against unwanted signals and noise. To enhance the robustness of KSN-807A-119+, each internal component is secured to the substrate with chip bonder, thereby eliminating the risk of tombstoning during subsequent solder reflow operations by the customer.



CASE STYLE: DK801
PRICE: \$29.95 ea. QTY (1-9)

+ RoHS compliant in accordance with EU Directive (2002/95/EC)

The +Suffix has been added in order to identify RoHS Compliance. See our web site for RoHS Compliance methodologies and qualifications.

Simplified Schematic



Electrical Specifications (over operating temperature -40°C to +85°C)

Parameters		Test Conditions	Min.	Typ.	Max.	Units	
Frequency Range		-	776	-	807	MHz	
Step Size		-	-	50	-	kHz	
Settling Time		Within ± 1 kHz	-	20	-	mSec	
Output Power		-	-2.5	+0.3	+2.5	dBm	
SSB Phase Noise		@ 100 Hz offset	-	-76	-	dBc/Hz	
		@ 1 kHz offset	-	-81	-76		
		@ 10 kHz offset	-	-111	-108		
		@ 100 kHz offset	-	-135	-129		
		@ 1 MHz offset	-	-153	-147		
Integrated SSB Phase Noise		@ 100 Hz to 1 MHz	-	-44	-33	dBc	
Reference Spurious Suppression		Ref. Freq. 15 MHz	-	-110	-86	dBc	
Comparison Spurious Suppression		Step Size 50 kHz	-	-85	-65		
Non - Harmonic Spurious Suppression		-	-	-90	-		
Harmonic Suppression		-	-	-27	-21		
VCO Supply Voltage		5.00	4.75	5.00	5.25		V
PLL Supply Voltage		5.00	4.75	5.00	5.25		
VCO Supply Current		-	-	33	40	mA	
PLL Supply Current		-	-	9	18		
Reference Input (External)		Frequency	15 (square wave)	-	15	-	MHz
		Amplitude	1.0	0.8	1.0	1.2	V_{P-P}
		Input impedance	-	-	100	-	K Ω
		Phase Noise @ 1 kHz offset	-	-	-140	-	dBc/Hz
RF Output port Impedance		-	-	50	-	Ω	
Input Logic Level		Input high voltage	-	4.20	-	-	V
		Input low voltage	-	-	-	0.95	V
Digital Lock Detect		Locked	-	4.35	-	5.25	V
		Unlocked	-	-	-	0.40	V
Frequency Synthesizer PLL		-	ADF4113				
PLL Programming		-	3-wire serial 5V CMOS				
Register Map @ 807 MHz		F_Register	-	(MSB) 010111111000000010010011 (LSB)			
		N_Register	-	(MSB) 000000111111000000110001 (LSB)			
		R_Register	-	(MSB) 000100000000010010110000 (LSB)			

Absolute Maximum Ratings

Parameters	Ratings
VCO Supply Voltage	6V
PLL Supply Voltage	6V
VCO Supply Voltage to PLL Supply Voltage	N.A.
Reference Frequency Voltage	-0.3Vmin, VCC PLL +0.3Vmax
Data, Clock, LE Levels	-0.3Vmin, VCC PLL +0.3Vmax
Operating Temperature	-40°C to +85°C
Storage Temperature	-55°C to +100°C

Permanent damage may occur if any of these limits are exceeded



IF/RF MICROWAVE COMPONENTS • ISO 9001 ISO 14001 AS 9100 CERTIFIED RoHS compliant

P.O. Box 350166, Brooklyn, New York 11235-0003 (718) 934-4500 Fax (718) 332-4661



The Design Engineers Search Engine finds the model you need, Instantly • For detailed performance specs & shopping online see



Notes: 1. Performance and quality attributes and conditions not expressly stated in this specification sheet are intended to be excluded and do not form a part of this specification sheet. 2. Electrical specifications and performance data contained herein are based on Mini-Circuit's applicable established test performance criteria and measurement instructions. 3. The parts covered by this specification sheet are subject to Mini-Circuits standard limited warranty and terms and conditions (collectively, "Standard Terms"); Purchasers of this part are entitled to the rights and benefits contained therein. For a full statement of the Standard Terms and the exclusive rights and remedies thereunder, please visit Mini-Circuits' website at www.minicircuits.com/MCLStore/terms.jsp.

Typical Performance Data

FREQUENCY (MHz)	POWER OUTPUT (dBm)			VCO CURRENT (mA)			PLL CURENT (mA)		
	-45°C	+25°C	+85°C	-45°C	+25°C	+85°C	-45°C	+25°C	+85°C
	776.0	0.05	0.34	0.20	31.49	33.16	34.35	8.83	8.93
778.6	0.04	0.33	0.19	31.48	33.16	34.36	8.84	8.94	12.86
784.8	0.02	0.30	0.18	31.47	33.16	34.38	8.84	8.94	12.87
791.0	-0.01	0.28	0.15	31.45	33.15	34.39	8.85	8.94	12.89
797.2	-0.03	0.25	0.13	31.43	33.15	34.39	8.86	8.95	12.89
803.4	-0.05	0.23	0.10	31.40	33.13	34.40	8.87	8.95	12.90
807.0	-0.06	0.21	0.09	31.39	33.12	34.39	8.87	8.96	12.91

FREQUENCY (MHz)	HARMONICS (dBc)					
	F2			F3		
	-45°C	+25°C	+85°C	-45°C	+25°C	+85°C
776.0	-25.58	-27.16	-27.81	-43.78	-44.27	-48.63
778.6	-25.72	-27.24	-27.92	-43.98	-44.93	-48.94
784.8	-26.32	-27.26	-28.53	-43.81	-45.78	-48.79
791.0	-26.45	-27.72	-28.75	-44.02	-46.32	-49.14
797.2	-26.58	-27.85	-28.86	-43.66	-45.61	-49.07
803.4	-27.16	-27.34	-29.40	-44.95	-45.31	-50.31
807.0	-27.30	-27.27	-29.55	-45.48	-45.79	-50.64

FREQUENCY (MHz)	PHASE NOISE (dBc/Hz) @ OFFSETS				
	+25°C				
	100Hz	1kHz	10kHz	100kHz	1MHz
776.0	-75.44	-82.08	-111.64	-135.57	-151.21
778.6	-76.10	-80.76	-111.97	-135.57	-151.92
784.8	-76.05	-82.16	-112.09	-135.80	-152.81
791.0	-76.15	-81.95	-111.65	-135.70	-153.57
797.2	-77.91	-81.16	-111.58	-135.61	-154.73
803.4	-75.04	-81.34	-111.54	-135.62	-153.95
807.0	-76.14	-81.75	-111.61	-134.85	-156.10

FREQUENCY (MHz)	PHASE NOISE (dBc/Hz) @ OFFSETS				
	-45°C				
	100Hz	1kHz	10kHz	100kHz	1MHz
776.0	-72.52	-80.56	-112.50	-134.81	-150.30
778.6	-76.19	-81.45	-112.33	-134.97	-152.80
784.8	-74.08	-81.48	-113.04	-135.43	-152.05
791.0	-73.94	-82.56	-113.33	-135.54	-150.90
797.2	-73.04	-83.08	-113.35	-135.49	-152.84
803.4	-75.86	-81.26	-113.55	-136.03	-150.34
807.0	-72.12	-81.43	-113.37	-135.88	-152.24

FREQUENCY (MHz)	PHASE NOISE (dBc/Hz) @ OFFSETS				
	+85°C				
	100Hz	1kHz	10kHz	100kHz	1MHz
776.0	-74.20	-81.27	-111.38	-132.82	-151.22
778.6	-74.49	-80.98	-111.10	-133.31	-150.91
784.8	-79.02	-80.45	-111.65	-133.69	-150.88
791.0	-73.97	-82.00	-112.00	-133.62	-151.61
797.2	-73.08	-80.91	-111.45	-133.50	-152.05
803.4	-72.50	-80.93	-111.40	-133.74	-154.15
807.0	-72.89	-81.80	-111.35	-132.60	-153.63



IF/RF MICROWAVE COMPONENTS • ISO 9001 ISO 14001 AS9100 CERTIFIED RoHS compliant
 P.O. Box 350166, Brooklyn, New York 11235-0003 (718) 934-4500 Fax (718) 332-4661



The Design Engineers Search Engine finds the model you need, Instantly • For detailed performance specs & shopping online see



Notes: 1. Performance and quality attributes and conditions not expressly stated in this specification sheet are intended to be excluded and do not form a part of this specification sheet. 2. Electrical specifications and performance data contained herein are based on Mini-Circuit's applicable established test performance criteria and measurement instructions. 3. The parts covered by this specification sheet are subject to Mini-Circuits standard limited warranty and terms and conditions (collectively, "Standard Terms"); Purchasers of this part are entitled to the rights and benefits contained therein. For a full statement of the Standard Terms and the exclusive rights and remedies thereunder, please visit Mini-Circuits' website at www.minicircuits.com/MCLStore/terms.jsp.

COMPARISON SPURIOUS ORDER	COMPARISON SPURIOUS @Fcarrier 776MHz+(n*Fcomparison) (dBc) note 1			COMPARISON SPURIOUS @Fcarrier 791MHz+(n*Fcomparison) (dBc) note 1			COMPARISON SPURIOUS @Fcarrier 807MHz+(n*Fcomparison) (dBc) note 1		
	n	-45°C	+25°C	+85°C	-45°C	+25°C	+85°C	-45°C	+25°C
-5	-87.18	-88.71	-98.84	-92.15	-93.08	-97.70	-98.79	-100.28	-98.68
-4	-95.58	-89.01	-97.60	-91.86	-97.04	-93.59	-98.57	-95.59	-98.16
-3	-85.72	-86.28	-93.73	-88.06	-92.45	-91.07	-89.94	-87.53	-93.44
-2	-85.32	-84.99	-86.37	-83.63	-84.36	-84.14	-86.45	-84.17	-82.89
-1	-81.42	-80.69	-80.67	-81.73	-84.59	-82.86	-84.08	-89.49	-83.38
0 note 2	-	-	-	-	-	-	-	-	-
+1	-81.36	-76.55	-81.50	-83.22	-81.68	-85.03	-85.18	-105.97	-84.47
+2	-86.55	-81.67	-85.80	-87.10	-81.49	-88.53	-88.70	-107.49	-85.81
+3	-91.72	-88.25	-91.99	-93.26	-86.09	-89.73	-93.20	-108.28	-91.18
+4	-91.23	-89.00	-95.10	-93.58	-96.91	-99.36	-97.09	-112.95	-97.06
+5	-90.24	-89.55	-94.26	-92.43	-92.05	-98.54	-94.21	-114.04	-100.12

Note 1: Comparison frequency 50 kHz

Note 2: All spurs are referenced to carrier signal (n=0).

REFERENCE SPURIOUS ORDER	REFERENCE SPURIOUS @Fcarrier 776MHz+(n*Freference) (dBc) note 3			REFERENCE SPURIOUS @Fcarrier 791MHz+(n*Freference) (dBc) note 3			REFERENCE SPURIOUS @Fcarrier 807MHz+(n*Freference) (dBc) note 3		
	n	-45°C	+25°C	+85°C	-45°C	+25°C	+85°C	-45°C	+25°C
-5	-113.13	-114.21	-114.54	-113.54	-115.91	-115.07	-116.04	-114.30	-117.62
-4	-102.20	-101.93	-103.88	-101.56	-102.39	-103.90	-102.05	-102.56	-103.89
-3	-117.02	-124.51	-116.63	-126.73	-126.22	-119.98	-126.89	-123.38	-115.96
-2	-105.69	-107.05	-108.86	-105.80	-108.32	-108.57	-106.91	-108.12	-109.13
-1	-113.05	-116.71	-124.94	-114.14	-118.71	-120.69	-115.88	-115.53	-124.06
0 note 4	-	-	-	-	-	-	-	-	-
+1	-117.53	-119.83	-117.78	-119.57	-126.62	-120.86	-123.36	-119.52	-115.83
+2	-108.25	-108.23	-110.84	-107.71	-126.75	-110.44	-107.70	-108.64	-109.59
+3	-113.45	-118.50	-118.57	-115.07	-130.07	-118.94	-117.81	-118.86	-118.39
+4	-104.05	-103.64	-104.62	-103.04	-128.75	-104.11	-103.91	-103.97	-105.06
+5	-115.25	-117.38	-116.36	-115.33	-127.18	-117.05	-115.09	-115.52	-115.64

Note 3: Reference frequency 15 MHz

Note 4: All spurs are referenced to carrier signal (n=0).



IF/RF MICROWAVE COMPONENTS • ISO 9001 ISO 14001 AS9100 CERTIFIED RoHS compliant

P.O. Box 350166, Brooklyn, New York 11235-0003 (718) 934-4500 Fax (718) 332-4661



The Design Engineers Search Engine finds the model you need, Instantly • For detailed performance specs & shopping online see



Notes: 1. Performance and quality attributes and conditions not expressly stated in this specification sheet are intended to be excluded and do not form a part of this specification sheet. 2. Electrical specifications and performance data contained herein are based on Mini-Circuit's applicable established test performance criteria and measurement instructions. 3. The parts covered by this specification sheet are subject to Mini-Circuits standard limited warranty and terms and conditions (collectively, "Standard Terms"); Purchasers of this part are entitled to the rights and benefits contained therein. For a full statement of the Standard Terms and the exclusive rights and remedies thereunder, please visit Mini-Circuits' website at www.minicircuits.com/MCLStore/terms.jsp.

Typical Performance Curves

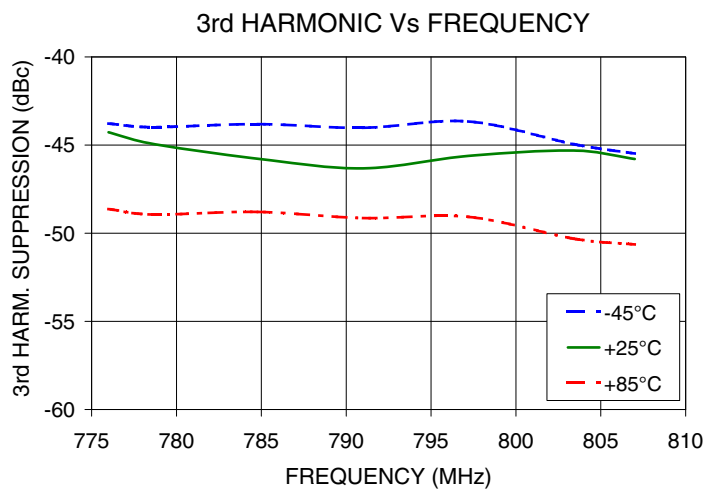
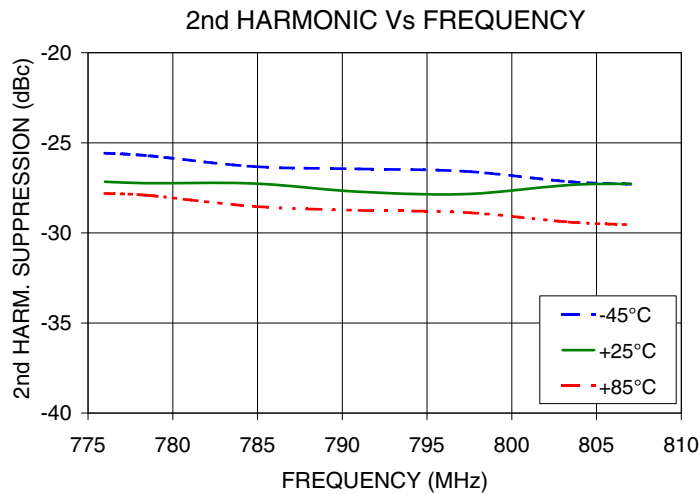
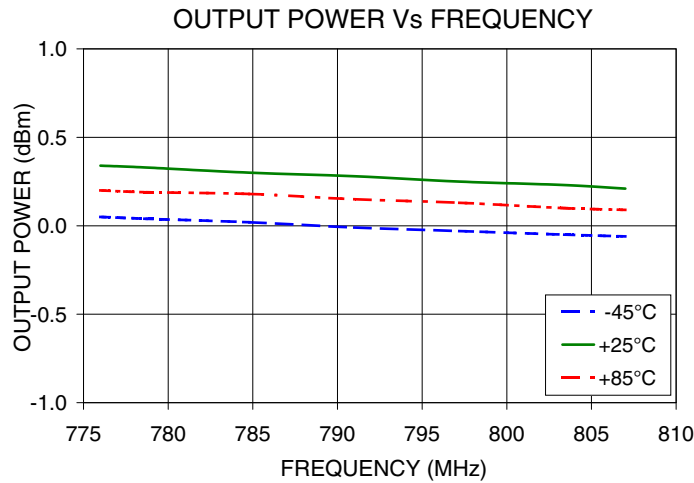

IF/RF MICROWAVE COMPONENTS • ISO 9001 ISO 14001 AS9100 CERTIFIED RoHS compliant
 P.O. Box 350166, Brooklyn, New York 11235-0003 (718) 934-4500 Fax (718) 332-4661



The Design Engineers Search Engine finds the model you need, Instantly • For detailed performance specs & shopping online see



Notes: 1. Performance and quality attributes and conditions not expressly stated in this specification sheet are intended to be excluded and do not form a part of this specification sheet. 2. Electrical specifications and performance data contained herein are based on Mini-Circuit's applicable established test performance criteria and measurement instructions. 3. The parts covered by this specification sheet are subject to Mini-Circuits standard limited warranty and terms and conditions (collectively, "Standard Terms"); Purchasers of this part are entitled to the rights and benefits contained therein. For a full statement of the Standard Terms and the exclusive rights and remedies thereunder, please visit Mini-Circuits' website at www.minicircuits.com/MCLStore/terms.jsp.

PHASE NOISE @100Hz offset

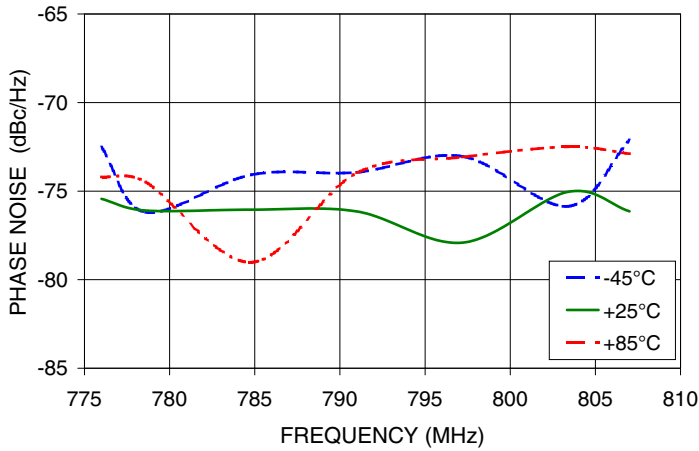

PHASE NOISE @1kHz offset

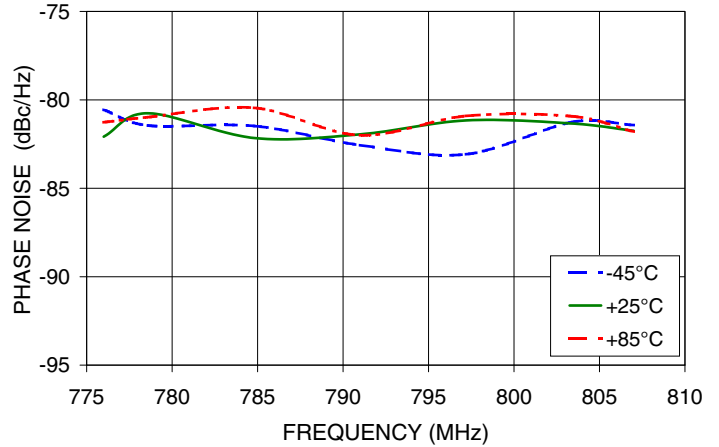

PHASE NOISE @10kHz offset

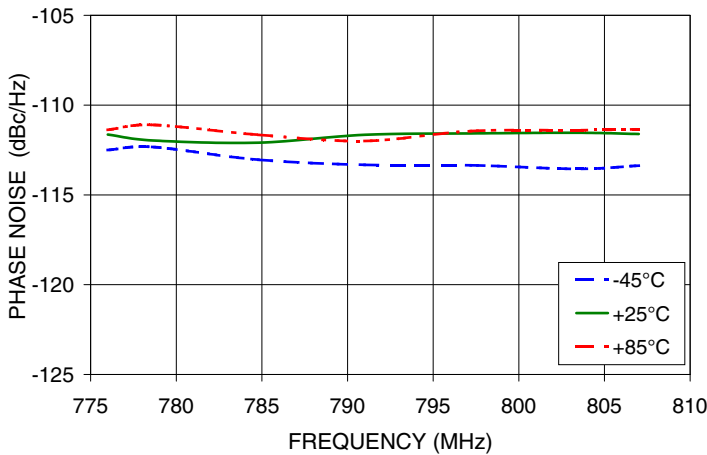

PHASE NOISE @100kHz offset

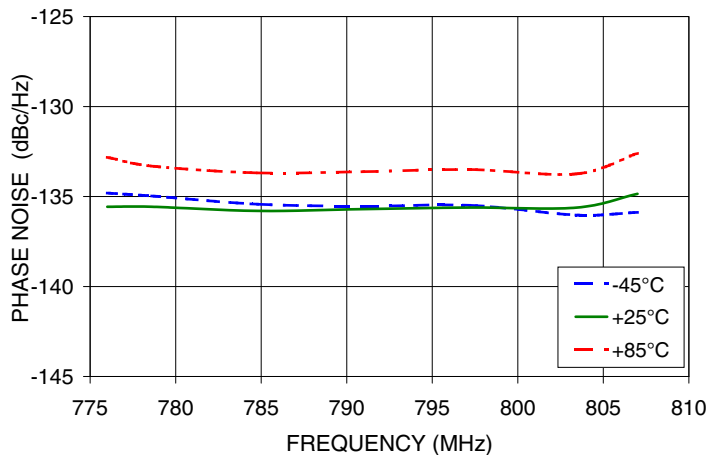

PHASE NOISE @1MHz offset

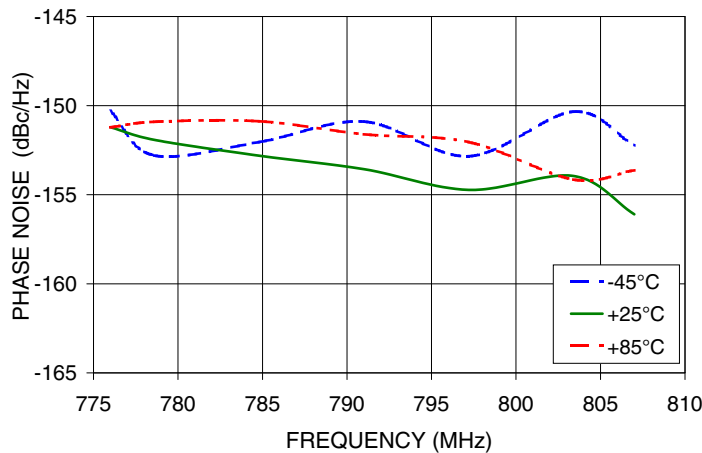

IF/RF MICROWAVE COMPONENTS • ISO 9001 ISO 14001 AS9100 CERTIFIED RoHS compliant
 P.O. Box 350166, Brooklyn, New York 11235-0003 (718) 934-4500 Fax (718) 332-4661



The Design Engineers Search Engine finds the model you need, Instantly • For detailed performance specs & shopping online see



Notes: 1. Performance and quality attributes and conditions not expressly stated in this specification sheet are intended to be excluded and do not form a part of this specification sheet. 2. Electrical specifications and performance data contained herein are based on Mini-Circuit's applicable established test performance criteria and measurement instructions. 3. The parts covered by this specification sheet are subject to Mini-Circuits standard limited warranty and terms and conditions (collectively, "Standard Terms"); Purchasers of this part are entitled to the rights and benefits contained therein. For a full statement of the Standard Terms and the exclusive rights and remedies thereunder, please visit Mini-Circuits' website at www.minicircuits.com/MCLStore/terms.jsp.

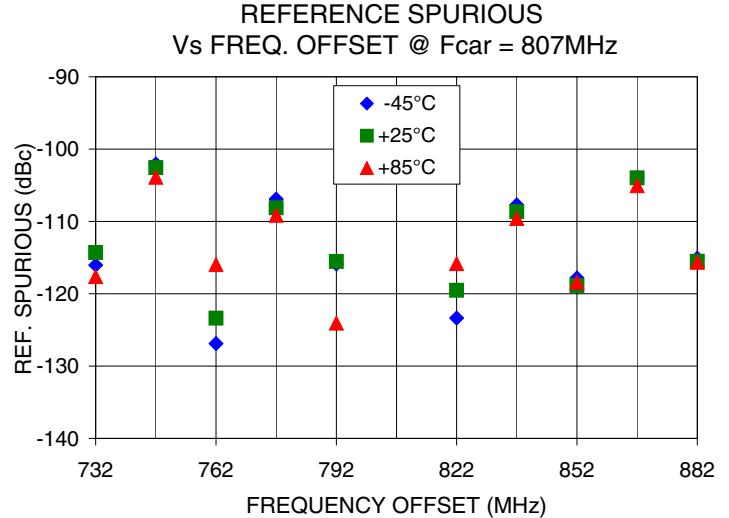
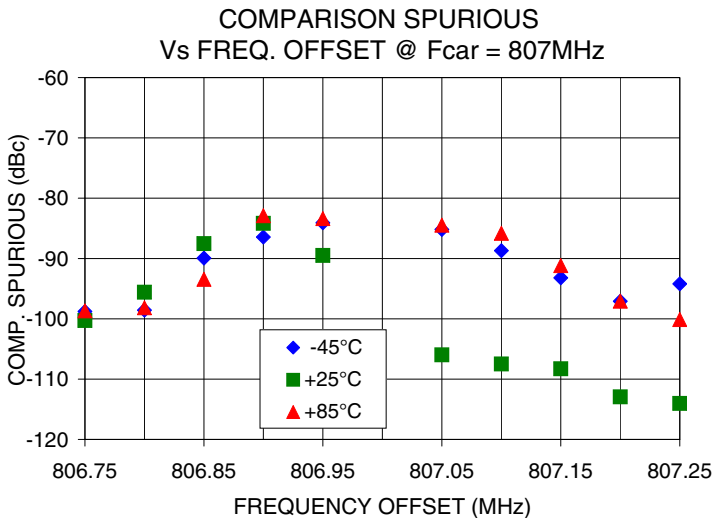
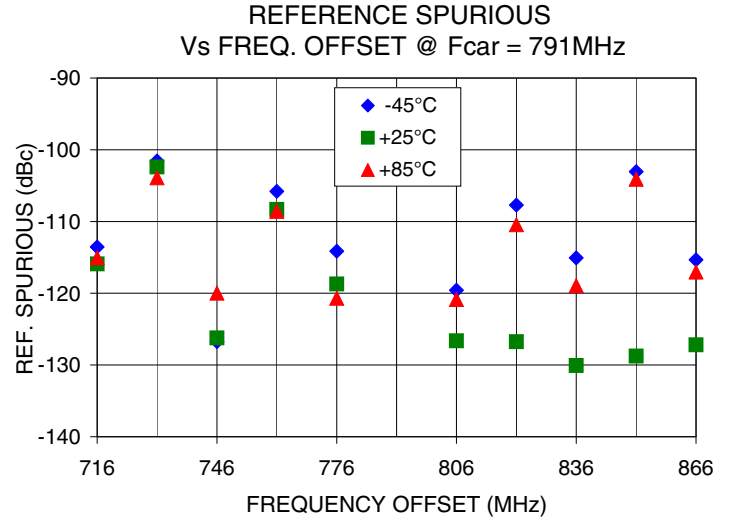
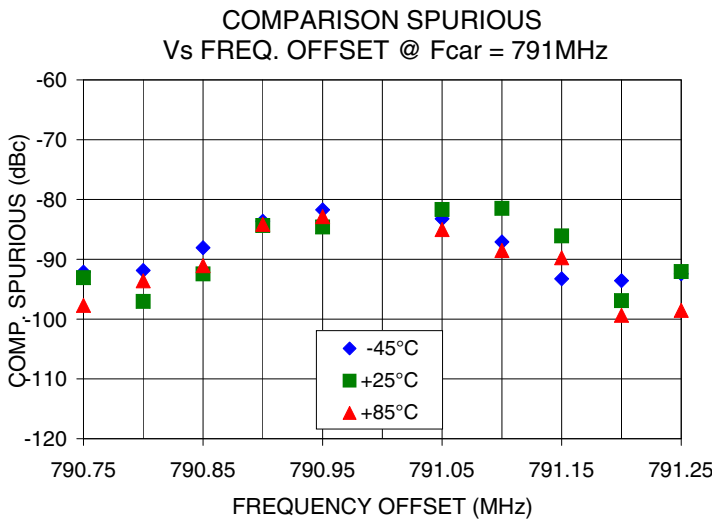
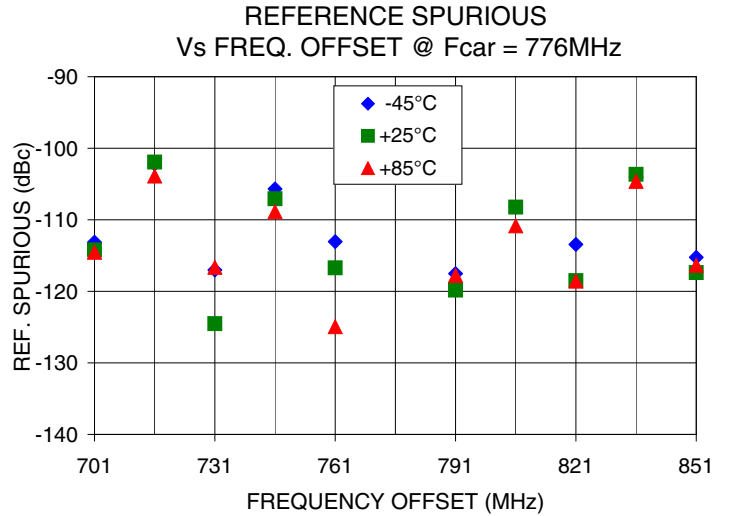
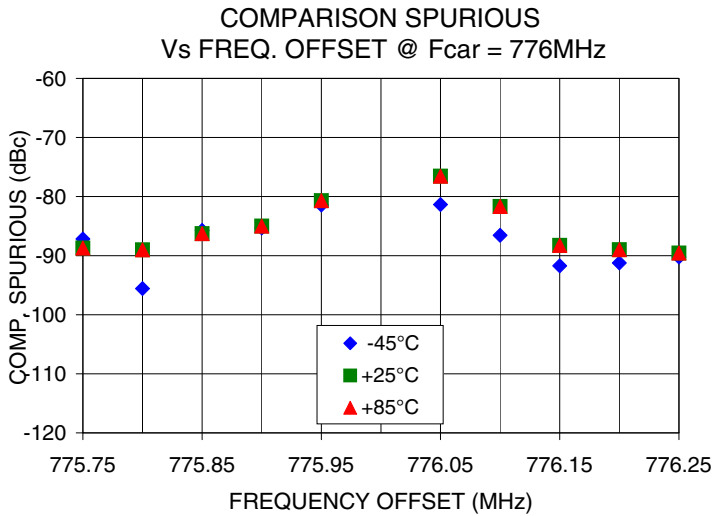

IF/RF MICROWAVE COMPONENTS • ISO 9001 ISO 14001 AS9100 CERTIFIED RoHS compliant
P.O. Box 350166, Brooklyn, New York 11235-0003 (718) 934-4500 Fax (718) 332-4661



The Design Engineers Search Engine finds the model you need, Instantly • For detailed performance specs & shopping online see



Notes: 1. Performance and quality attributes and conditions not expressly stated in this specification sheet are intended to be excluded and do not form a part of this specification sheet. 2. Electrical specifications and performance data contained herein are based on Mini-Circuit's applicable established test performance criteria and measurement instructions. 3. The parts covered by this specification sheet are subject to Mini-Circuits standard limited warranty and terms and conditions (collectively, "Standard Terms"); Purchasers of this part are entitled to the rights and benefits contained therein. For a full statement of the Standard Terms and the exclusive rights and remedies thereunder, please visit Mini-Circuits' website at www.minicircuits.com/MCLStore/terms.jsp.

Pin Configuration

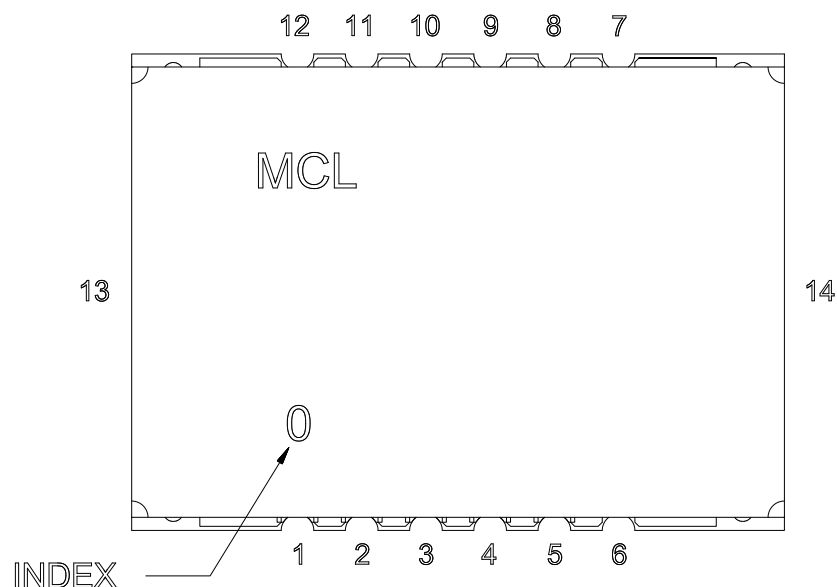

Pin Connection

Pin Number	Function
1	VCC PLL
2	GND
3	REF IN
4	GND
5	VCC VCO
6	GND
7	RF OUT
8	GND
9	LOCK DET
10	CLOCK
11	DATA
12	LE
13	GND
14	GND

Recommended Application Circuit

Note: REF IN and RF OUT ports are internally AC coupled.

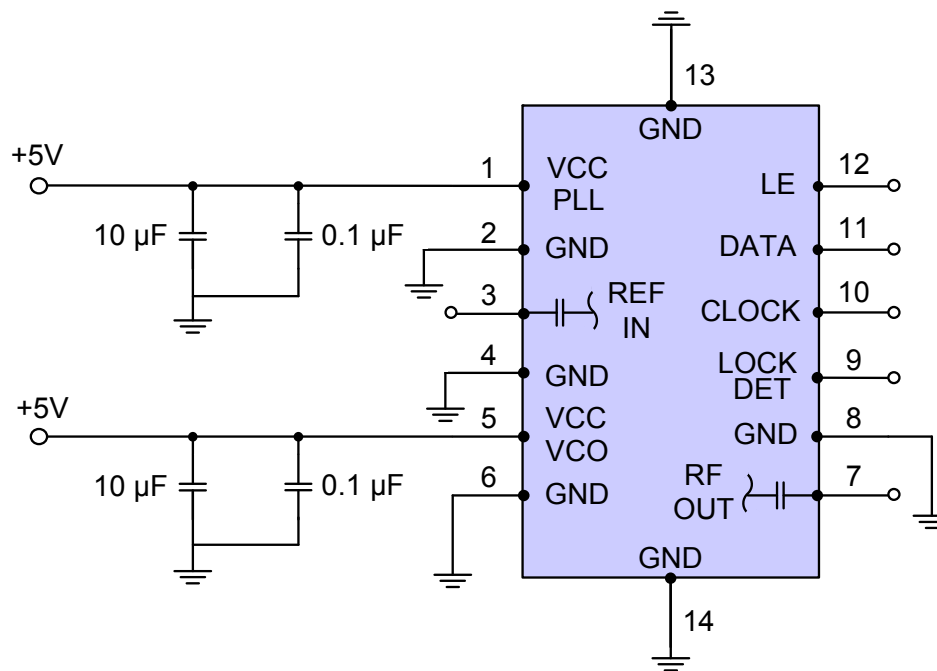

IF/RF MICROWAVE COMPONENTS • ISO 9001 ISO 14001 AS9100 CERTIFIED RoHS compliant
 P.O. Box 350166, Brooklyn, New York 11235-0003 (718) 934-4500 Fax (718) 332-4661



The Design Engineers Search Engine finds the model you need, Instantly • For detailed performance specs & shopping online see



Notes: 1. Performance and quality attributes and conditions not expressly stated in this specification sheet are intended to be excluded and do not form a part of this specification sheet. 2. Electrical specifications and performance data contained herein are based on Mini-Circuit's applicable established test performance criteria and measurement instructions. 3. The parts covered by this specification sheet are subject to Mini-Circuits standard limited warranty and terms and conditions (collectively, "Standard Terms"); Purchasers of this part are entitled to the rights and benefits contained therein. For a full statement of the Standard Terms and the exclusive rights and remedies thereunder, please visit Mini-Circuits' website at www.minicircuits.com/MCLStore/terms.jsp.

Device Marking

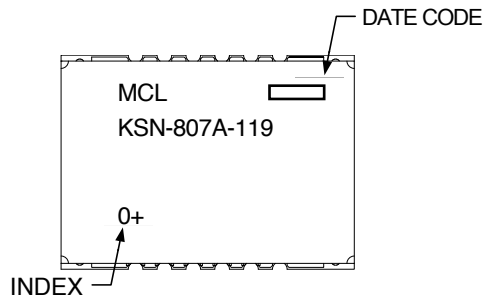

Additional Detailed Technical Information

Additional information is available on our web site. To access this information enter the model number on our web site home page.

Case Style: DK801

Tape & Reel: TR-F28

Suggested Layout for PCB Design: PL-249

Evaluation Board: TB-567+

Environment Ratings: ENV03T2



IF/RF MICROWAVE COMPONENTS • ISO 9001 ISO 14001 AS9100 CERTIFIED RoHS compliant
P.O. Box 350166, Brooklyn, New York 11235-0003 (718) 934-4500 Fax (718) 332-4661



The Design Engineers Search Engine finds the model you need, Instantly • For detailed performance specs & shopping online see



Notes: 1. Performance and quality attributes and conditions not expressly stated in this specification sheet are intended to be excluded and do not form a part of this specification sheet. 2. Electrical specifications and performance data contained herein are based on Mini-Circuit's applicable established test performance criteria and measurement instructions. 3. The parts covered by this specification sheet are subject to Mini-Circuits standard limited warranty and terms and conditions (collectively, "Standard Terms"); Purchasers of this part are entitled to the rights and benefits contained therein. For a full statement of the Standard Terms and the exclusive rights and remedies thereunder, please visit Mini-Circuits' website at www.minicircuits.com/MCLStore/terms.jsp.