

Frequency Synthesizer

KSN-578A-119+

50Ω 567.52 to 577.52 MHz

The Big Deal

- Low phase noise and spurious
- Robust design and construction
- Small size 0.80" x 0.58" x 0.15"



CASE STYLE: DK801

Product Overview

The KSN-578A-119+ is a Frequency Synthesizer, designed to operate from 567.52 to 577.52 MHz for CDMA application. The KSN-578A-119+ is packaged in a metal case (size of 0.80" x 0.58" x 0.15") to shield against unwanted signals and noise.

Key Features

Feature	Advantages
Low phase noise and spurious: <ul style="list-style-type: none">• Phase Noise: -112 dBc/Hz typ. @ 10 kHz offset• Comparison Spurious: -68 dBc typ.• Reference Spurious: -119 dBc typ.	Low phase noise and spurious improve system EVM (Error Vector Magnitude).
Robust design and construction.	To enhance the robustness of KSN-578A-119+, each internal component is secured to the substrate with chip bonder, thereby eliminating the risk of tombstoning during subsequent solder reflow operations by the customer.
Small size, 0.80" x 0.58" x 0.15"	The small size enables the KSN-578A-119+ to be used in compact designs.



IF/RF MICROWAVE COMPONENTS • ISO 9001 ISO 14001 AS9100 CERTIFIED RoHS compliant
P.O. Box 350166, Brooklyn, New York 11235-0003 (718) 934-4500 Fax (718) 332-4661



The Design Engineers Search Engine finds the model you need, Instantly • For detailed performance specs & shopping online see



Notes: 1. Performance and quality attributes and conditions not expressly stated in this specification sheet are intended to be excluded and do not form a part of this specification sheet. 2. Electrical specifications and performance data contained herein are based on Mini-Circuit's applicable established test performance criteria and measurement instructions. 3. The parts covered by this specification sheet are subject to Mini-Circuits standard limited warranty and terms and conditions (collectively, "Standard Terms"); Purchasers of this part are entitled to the rights and benefits contained therein. For a full statement of the Standard Terms and the exclusive rights and remedies thereunder, please visit Mini-Circuits' website at www.minicircuits.com/MCLStore/terms.jsp.

50Ω 567.52 to 577.52 MHz

Features

- Integrated VCO + PLL
- Low phase noise and spurious
- Robust design and construction
- Low operating voltage (VCC VCO=+5V, VCC PLL=+3.3V)
- Small size 0.80" x 0.58" x 0.15"

Applications

- CDMA

General Description

The KSN-578A-119+ is a Frequency Synthesizer, designed to operate from 567.52 to 577.52 MHz for CDMA application. The KSN-578A-119+ is packaged in a metal case (size of 0.80" x 0.58" x 0.15") to shield against unwanted signals and noise. To enhance the robustness of KSN-578A-119+, each internal component is secured to the substrate with chip bonder, thereby eliminating the risk of tombstoning during subsequent solder reflow operations by the customer.



CASE STYLE: DK801
PRICE: \$29.95 ea. QTY (1-9)

+ RoHS compliant in accordance with EU Directive (2002/95/EC)

The +Suffix has been added in order to identify RoHS Compliance. See our web site for RoHS Compliance methodologies and qualifications.

Simplified Schematic

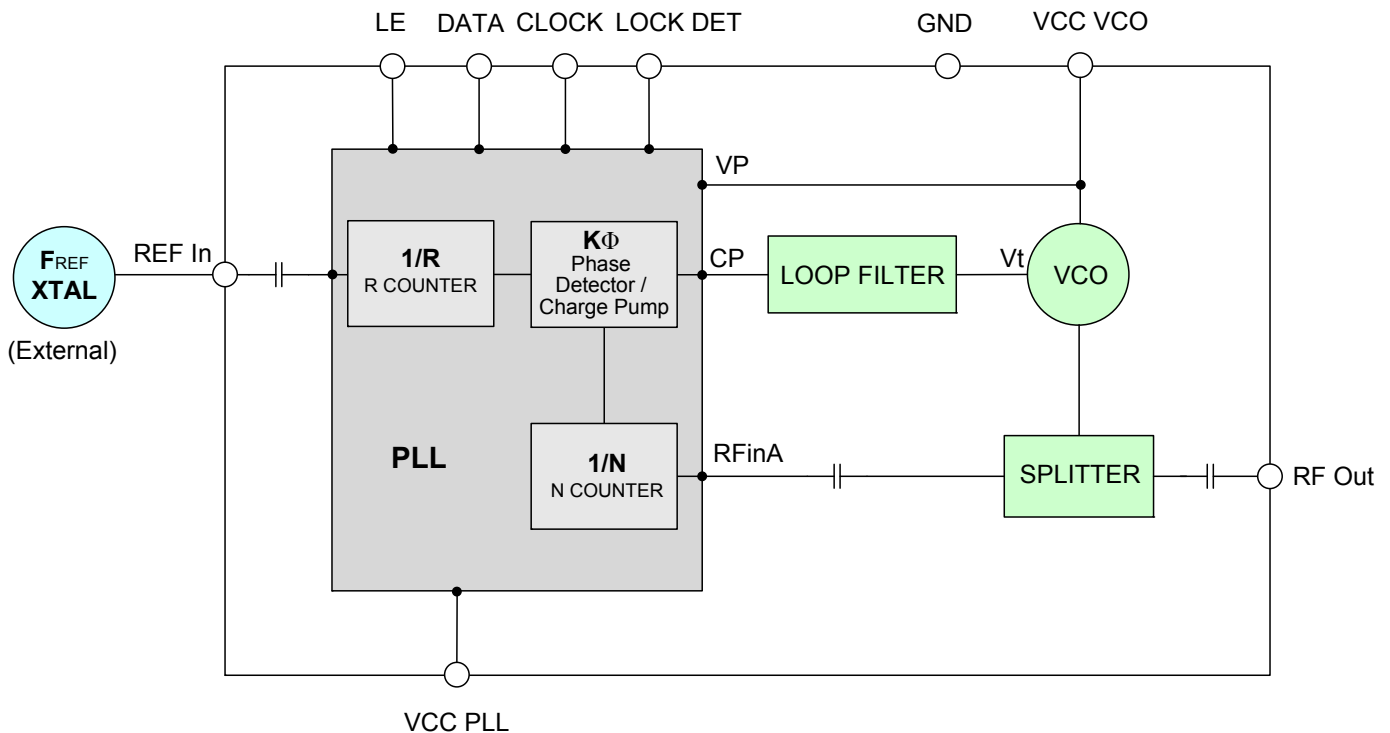

IF/RF MICROWAVE COMPONENTS • ISO 9001 ISO 14001 AS9100 CERTIFIED RoHS compliant
P.O. Box 350166, Brooklyn, New York 11235-0003 (718) 934-4500 Fax (718) 332-4661



The Design Engineers Search Engine finds the model you need, Instantly • For detailed performance specs & shopping online see



Notes: 1. Performance and quality attributes and conditions not expressly stated in this specification sheet are intended to be excluded and do not form a part of this specification sheet. 2. Electrical specifications and performance data contained herein are based on Mini-Circuit's applicable established test performance criteria and measurement instructions. 3. The parts covered by this specification sheet are subject to Mini-Circuits standard limited warranty and terms and conditions (collectively, "Standard Terms"); Purchasers of this part are entitled to the rights and benefits contained therein. For a full statement of the Standard Terms and the exclusive rights and remedies thereunder, please visit Mini-Circuits' website at www.minicircuits.com/MCLStore/terms.jsp.

Electrical Specifications (over operating temperature -10°C to +85°C)

Parameters	Test Conditions	Min.	Typ.	Max.	Units
Frequency Range	-	567.52	-	577.52	MHz
Step Size	-	-	5	-	kHz
Settling Time	Within ± 1 kHz	-	140	-	mSec
Output Power	-	-3	0.2	+3	dBm
SSB Phase Noise	@ 100 Hz offset	-	-68	-	dBc/Hz
	@ 1 kHz offset	-	-79	-75	
	@ 10 kHz offset	-	-112	-108	
	@ 100 kHz offset	-	-134	-130	
	@ 1 MHz offset	-	-154	-149	
Reference Spurious Suppression	Ref. Freq. 15 MHz	-	-119	-90	dBc
Comparison Spurious Suppression	Step Size 5 kHz	-	-68	-50	
Non - Harmonic Spurious Suppression	-	-	-90	-	
Harmonic Suppression	-	-	-26	-22	
VCO Supply Voltage	+5.00	+4.75	+5.00	+5.25	
PLL Supply Voltage	+3.30	+3.15	+3.30	+3.45	
VCO Supply Current	-	-	21	28	mA
PLL Supply Current	-	-	9	17	
Reference Input (External)	Frequency	15 (square wave)	-	15	MHz
	Amplitude	1	-	1	V _{P-P}
	Input impedance	-	-	100	KΩ
	Phase Noise @ 1 kHz offset	-	-	-140	dBc/Hz
RF Output port Impedance	-	-	50	-	Ω
Input Logic Level	Input high voltage	-	2.60	-	V
	Input low voltage	-	-	0.55	V
Digital Lock Detect	Locked	-	2.50	-	V
	Unlocked	-	-	0.40	V
Frequency Synthesizer PLL	-	ADF4113			
PLL Programming	-	3-wire serial 3.1V CMOS			
Register Map@ 577.52 MHz	F_Register	-	(MSB) 01011111100000010010011 (LSB)		
	N_Register	-	(MSB) 001111000011001100000001 (LSB)		
	R_Register	-	(MSB) 00000000010111011100000 (LSB)		

Absolute Maximum Ratings

Parameters	Ratings
VCO Supply Voltage	6V
PLL Supply Voltage	7V
VCO Supply Voltage to PLL Supply Voltage	N.A.
Reference Frequency Voltage	-0.3V min, +3.2V max
Data, Clock, LE Levels	-0.3V min, +3.2V max
Operating Temperature	-40°C to +85°C
Storage Temperature	-55°C to +100°C

Permanent damage may occur if any of these limits are exceeded



IF/RF MICROWAVE COMPONENTS • ISO 9001 ISO 14001 AS9100 CERTIFIED RoHS compliant
 P.O. Box 350166, Brooklyn, New York 11235-0003 (718) 934-4500 Fax (718) 332-4661
 The Design Engineers Search Engine finds the model you need, Instantly • For detailed performance specs & shopping online see minicircuits.com

Notes: 1. Performance and quality attributes and conditions not expressly stated in this specification sheet are intended to be excluded and do not form a part of this specification sheet. 2. Electrical specifications and performance data contained herein are based on Mini-Circuit's applicable established test performance criteria and measurement instructions. 3. The parts covered by this specification sheet are subject to Mini-Circuits standard limited warranty and terms and conditions (collectively, "Standard Terms"); Purchasers of this part are entitled to the rights and benefits contained therein. For a full statement of the Standard Terms and the exclusive rights and remedies thereunder, please visit Mini-Circuits' website at www.minicircuits.com/MCLStore/terms.jsp.

Typical Performance Data

FREQUENCY (MHz)	POWER OUTPUT (dBm)			VCO CURRENT (mA)			PLL CURENT (mA)		
	-15°C	+25°C	+85°C	-15°C	+25°C	+85°C	-15°C	+25°C	+85°C
	567.52	0.34	0.52	0.68	20.22	21.28	22.24	8.25	8.98
569.00	0.32	0.50	0.66	20.24	21.29	22.25	8.25	8.98	10.73
572.50	0.29	0.45	0.60	20.28	21.32	22.28	8.25	8.98	10.73
576.00	0.25	0.40	0.54	20.32	21.35	22.31	8.25	8.99	10.74
577.52	0.23	0.38	0.52	20.33	21.36	22.33	8.25	8.98	10.74

FREQUENCY (MHz)	HARMONICS (dBc)					
	F2			F3		
	-15°C	+25°C	+85°C	-15°C	+25°C	+85°C
567.52	-25.94	-26.31	-26.72	-34.39	-34.88	-35.29
569.00	-25.89	-26.35	-26.62	-34.42	-34.76	-34.87
572.50	-26.08	-26.46	-26.79	-34.16	-34.43	-34.88
576.00	-26.07	-26.51	-26.84	-34.03	-34.10	-34.76
577.52	-26.06	-26.44	-26.81	-33.92	-34.16	-34.40

FREQUENCY (MHz)	PHASE NOISE (dBc/Hz) @ OFFSETS				
	+25°C				
	100Hz	1kHz	10kHz	100kHz	1MHz
567.52	-70.04	-80.27	-111.69	-134.51	-154.97
569.00	-70.82	-79.60	-111.73	-134.41	-154.85
572.50	-72.39	-81.14	-111.70	-134.44	-154.79
576.00	-73.68	-79.95	-111.58	-134.38	-154.81
577.52	-70.71	-79.18	-111.57	-134.30	-154.73

FREQUENCY (MHz)	PHASE NOISE (dBc/Hz) @ OFFSETS				
	-15°C				
	100Hz	1kHz	10kHz	100kHz	1MHz
567.52	-73.82	-78.08	-110.64	-134.31	-154.48
569.00	-71.50	-77.95	-110.83	-134.50	-154.43
572.50	-73.67	-79.70	-110.08	-134.66	-154.48
576.00	-73.92	-78.46	-110.19	-134.84	-154.38
577.52	-74.63	-78.76	-110.90	-134.85	-155.27

FREQUENCY (MHz)	PHASE NOISE (dBc/Hz) @ OFFSETS				
	+85°C				
	100Hz	1kHz	10kHz	100kHz	1MHz
567.52	-69.38	-78.56	-111.13	-133.24	-153.47
569.00	-73.75	-79.47	-111.09	-133.20	-153.42
572.50	-71.82	-77.10	-111.24	-133.06	-153.36
576.00	-70.90	-77.35	-111.18	-133.10	-154.37
577.52	-70.44	-78.15	-111.18	-133.25	-154.02



IF/RF MICROWAVE COMPONENTS • ISO 9001 ISO 14001 AS9100 CERTIFIED RoHS compliant
 P.O. Box 350166, Brooklyn, New York 11235-0003 (718) 934-4500 Fax (718) 332-4661



The Design Engineers Search Engine finds the model you need, Instantly • For detailed performance specs & shopping online see



Notes: 1. Performance and quality attributes and conditions not expressly stated in this specification sheet are intended to be excluded and do not form a part of this specification sheet. 2. Electrical specifications and performance data contained herein are based on Mini-Circuit's applicable established test performance criteria and measurement instructions. 3. The parts covered by this specification sheet are subject to Mini-Circuits standard limited warranty and terms and conditions (collectively, "Standard Terms"); Purchasers of this part are entitled to the rights and benefits contained therein. For a full statement of the Standard Terms and the exclusive rights and remedies thereunder, please visit Mini-Circuits' website at www.minicircuits.com/MCLStore/terms.jsp.

COMPARISON SPURIOUS ORDER	COMPARISON SPURIOUS @Fcarrier 567.52MHz+(n*Fcomparison) (dBc) note 1			COMPARISON SPURIOUS @Fcarrier 572.52MHz+(n*Fcomparison) (dBc) note 1			COMPARISON SPURIOUS @Fcarrier 577.52MHz+(n*Fcomparison) (dBc) note 1		
	n			n			n		
	-15°C	+25°C	+85°C	-15°C	+25°C	+85°C	-15°C	+25°C	+85°C
-5	-96.09	-91.19	-85.05	-96.83	-91.03	-85.24	-96.46	-91.28	-86.14
-4	-91.68	-86.95	-83.52	-93.08	-88.52	-81.07	-80.59	-84.57	-80.79
-3	-89.08	-83.68	-77.73	-88.84	-86.16	-77.83	-89.46	-84.15	-83.96
-2	-83.13	-76.40	-72.51	-82.82	-81.15	-72.04	-81.47	-75.48	-76.62
-1	-74.00	-70.49	-60.20	-72.29	-69.92	-59.95	-74.58	-70.03	-59.37
0 note 2	-	-	-	-	-	-	-	-	-
+1	-74.37	-69.94	-58.26	-71.04	-67.78	-60.09	-73.63	-68.18	-59.20
+2	-82.33	-77.11	-70.52	-82.46	-79.50	-72.29	-81.74	-77.46	-72.54
+3	-89.10	-84.33	-80.38	-87.68	-86.62	-78.41	-88.56	-82.22	-82.38
+4	-90.90	-89.53	-82.93	-92.71	-86.94	-85.99	-83.02	-82.79	-78.91
+5	-95.29	-91.67	-88.09	-94.52	-88.48	-86.08	-97.06	-89.04	-85.54

Note 1: Comparison frequency 5 kHz
 Note 2: All spurs are referenced to carrier signal (n=0).

REFERENCE SPURIOUS ORDER	REFERENCE SPURIOUS @Fcarrier 567.52MHz+(n*Freference) (dBc) note 3			REFERENCE SPURIOUS @Fcarrier 572.52MHz+(n*Freference) (dBc) note 3			REFERENCE SPURIOUS @Fcarrier 577.52MHz+(n*Freference) (dBc) note 3		
	n			n			n		
	-15°C	+25°C	+85°C	-15°C	+25°C	+85°C	-15°C	+25°C	+85°C
-5	-126.29	-124.23	-123.39	-126.67	-127.79	-122.50	-126.17	-125.47	-125.58
-4	-125.11	-122.18	-123.89	-125.61	-126.80	-122.03	-126.60	-124.09	-127.59
-3	-123.95	-124.59	-126.07	-126.18	-126.38	-123.11	-127.49	-120.34	-124.96
-2	-124.86	-122.79	-125.80	-128.13	-122.23	-122.29	-127.04	-126.22	-123.86
-1	-125.23	-118.26	-118.37	-126.35	-121.77	-117.04	-126.29	-122.41	-116.36
0 note 4	-	-	-	-	-	-	-	-	-
+1	-118.05	-117.93	-124.65	-117.19	-121.15	-121.05	-116.57	-117.71	-117.95
+2	-130.24	-123.97	-123.18	-128.68	-123.90	-124.52	-127.66	-122.03	-124.87
+3	-128.21	-123.17	-125.10	-127.93	-123.26	-130.95	-128.47	-127.63	-122.55
+4	-128.13	-122.02	-126.21	-127.15	-124.93	-121.01	-127.91	-120.87	-123.07
+5	-126.33	-120.55	-129.36	-128.95	-125.23	-125.24	-128.68	-122.61	-123.47

Note 3: Reference frequency 15 MHz
 Note 4: All spurs are referenced to carrier signal (n=0).



IF/RF MICROWAVE COMPONENTS • ISO 9001 ISO 14001 AS9100 CERTIFIED RoHS compliant
 P.O. Box 350166, Brooklyn, New York 11235-0003 (718) 934-4500 Fax (718) 332-4661



Notes: 1. Performance and quality attributes and conditions not expressly stated in this specification sheet are intended to be excluded and do not form a part of this specification sheet. 2. Electrical specifications and performance data contained herein are based on Mini-Circuit's applicable established test performance criteria and measurement instructions. 3. The parts covered by this specification sheet are subject to Mini-Circuits standard limited warranty and terms and conditions (collectively, "Standard Terms"); Purchasers of this part are entitled to the rights and benefits contained therein. For a full statement of the Standard Terms and the exclusive rights and remedies thereunder, please visit Mini-Circuits' website at www.minicircuits.com/MCLStore/terms.jsp.

Typical Performance Curves

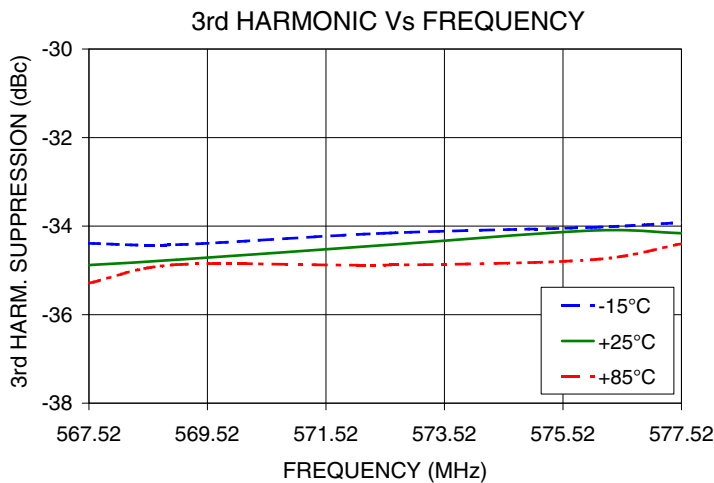
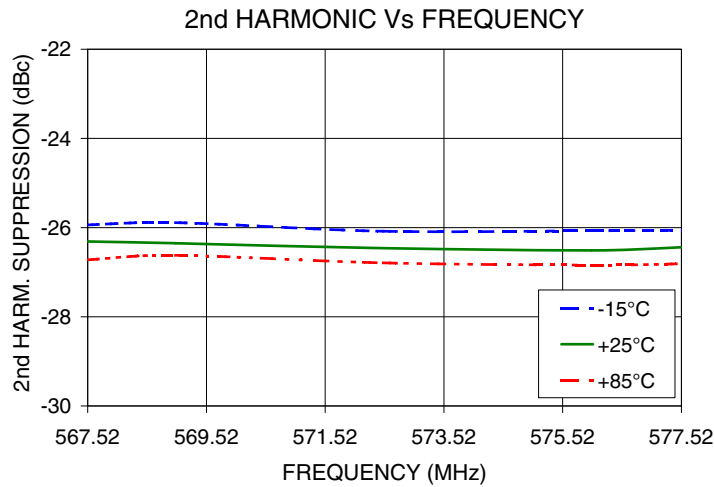
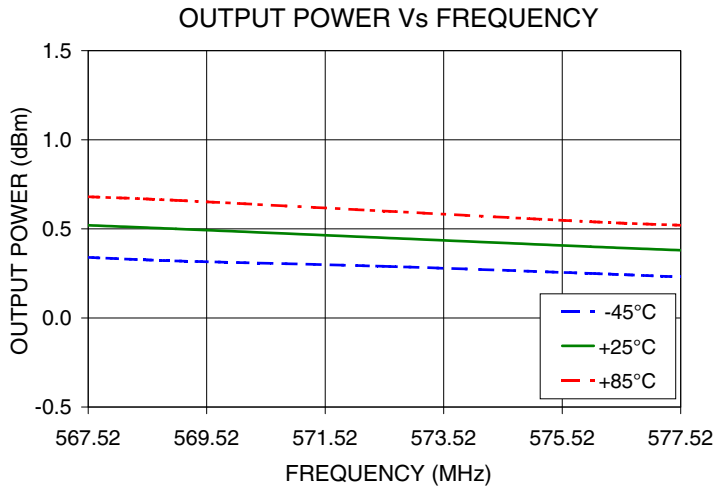

IF/RF MICROWAVE COMPONENTS • ISO 9001 ISO 14001 AS9100 CERTIFIED RoHS compliant
 P.O. Box 350166, Brooklyn, New York 11235-0003 (718) 934-4500 Fax (718) 332-4661



The Design Engineers Search Engine finds the model you need, Instantly • For detailed performance specs & shopping online see



Notes: 1. Performance and quality attributes and conditions not expressly stated in this specification sheet are intended to be excluded and do not form a part of this specification sheet. 2. Electrical specifications and performance data contained herein are based on Mini-Circuit's applicable established test performance criteria and measurement instructions. 3. The parts covered by this specification sheet are subject to Mini-Circuits standard limited warranty and terms and conditions (collectively, "Standard Terms"); Purchasers of this part are entitled to the rights and benefits contained therein. For a full statement of the Standard Terms and the exclusive rights and remedies thereunder, please visit Mini-Circuits' website at www.minicircuits.com/MCLStore/terms.jsp.

PHASE NOISE @100Hz offset

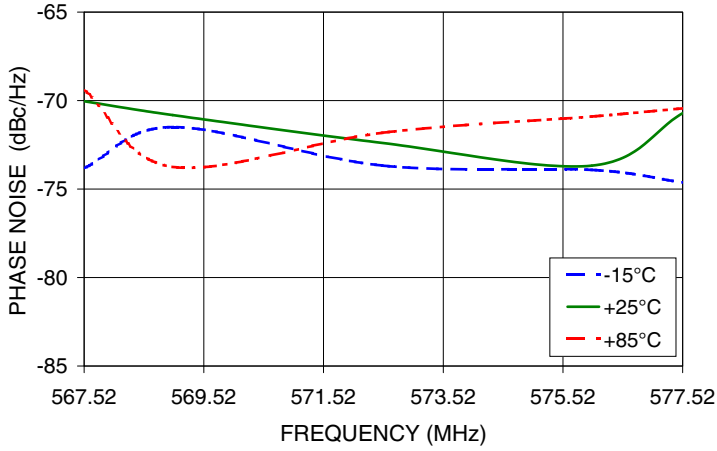

PHASE NOISE @1kHz offset

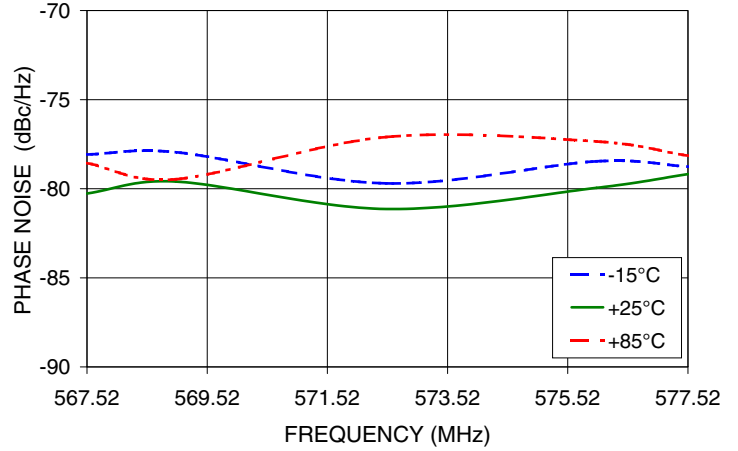

PHASE NOISE @10kHz offset

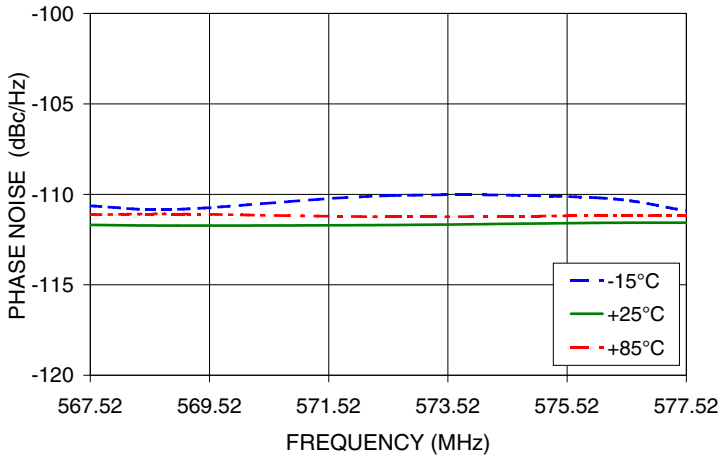

PHASE NOISE @100kHz offset

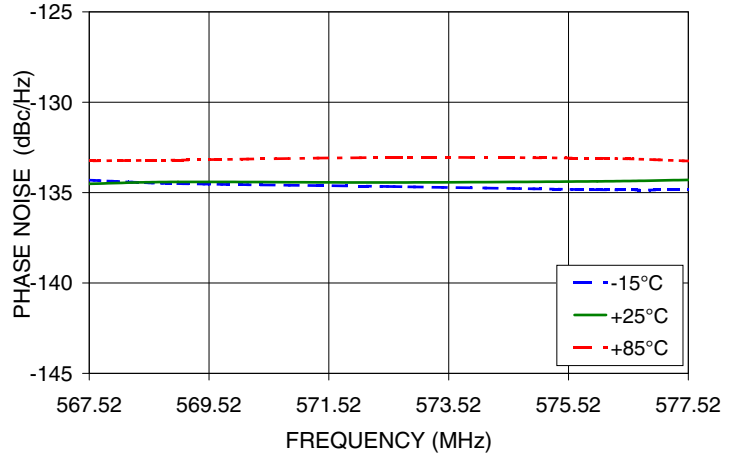

PHASE NOISE @1MHz offset

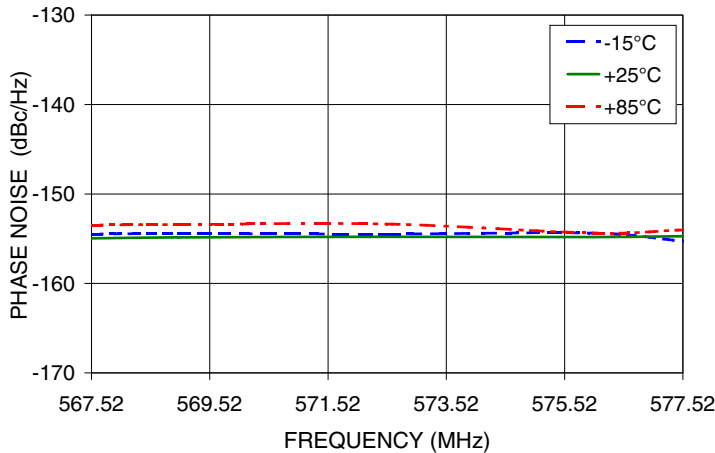

IF/RF MICROWAVE COMPONENTS • ISO 9001 ISO 14001 AS9100 CERTIFIED RoHS compliant
 P.O. Box 350166, Brooklyn, New York 11235-0003 (718) 934-4500 Fax (718) 332-4661



The Design Engineers Search Engine finds the model you need, Instantly • For detailed performance specs & shopping online see



Notes: 1. Performance and quality attributes and conditions not expressly stated in this specification sheet are intended to be excluded and do not form a part of this specification sheet. 2. Electrical specifications and performance data contained herein are based on Mini-Circuit's applicable established test performance criteria and measurement instructions. 3. The parts covered by this specification sheet are subject to Mini-Circuits standard limited warranty and terms and conditions (collectively, "Standard Terms"); Purchasers of this part are entitled to the rights and benefits contained therein. For a full statement of the Standard Terms and the exclusive rights and remedies thereunder, please visit Mini-Circuits' website at www.minicircuits.com/MCLStore/terms.jsp.

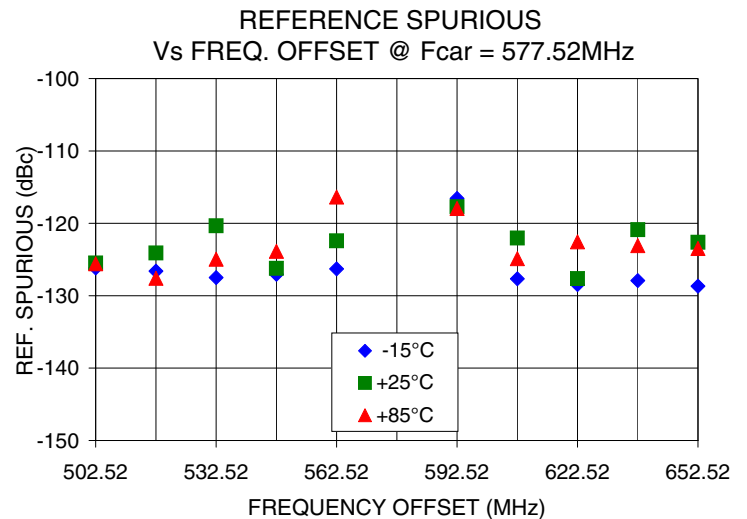
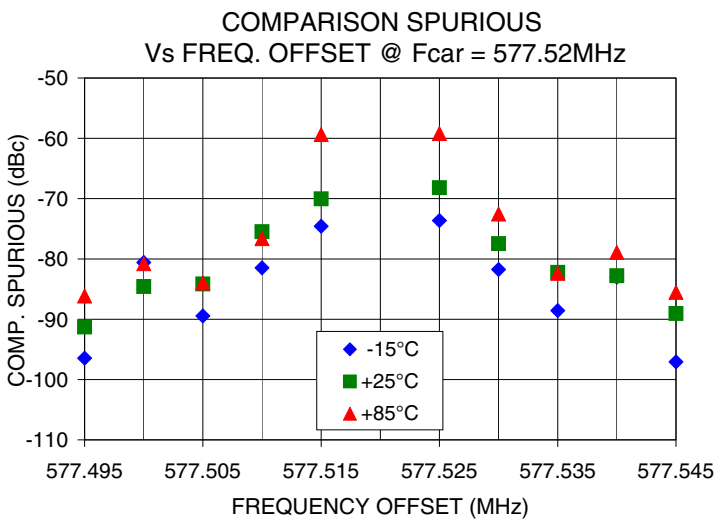
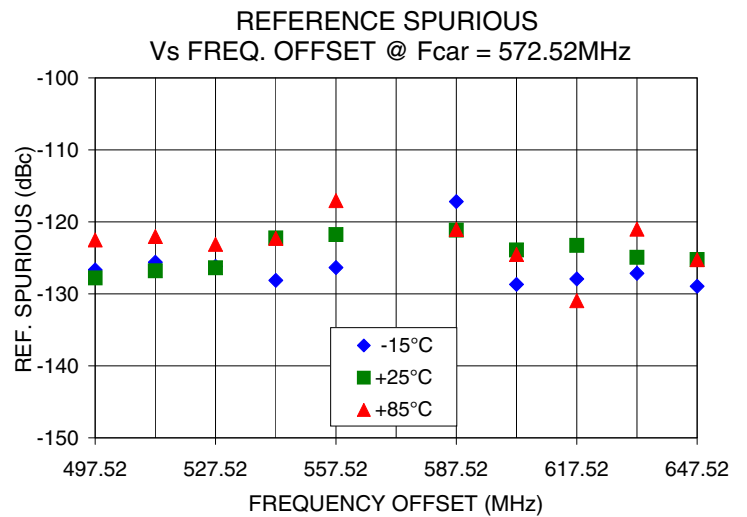
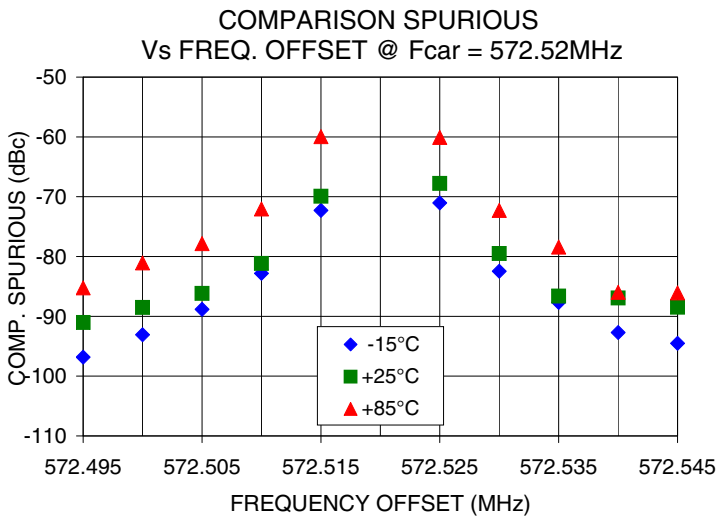
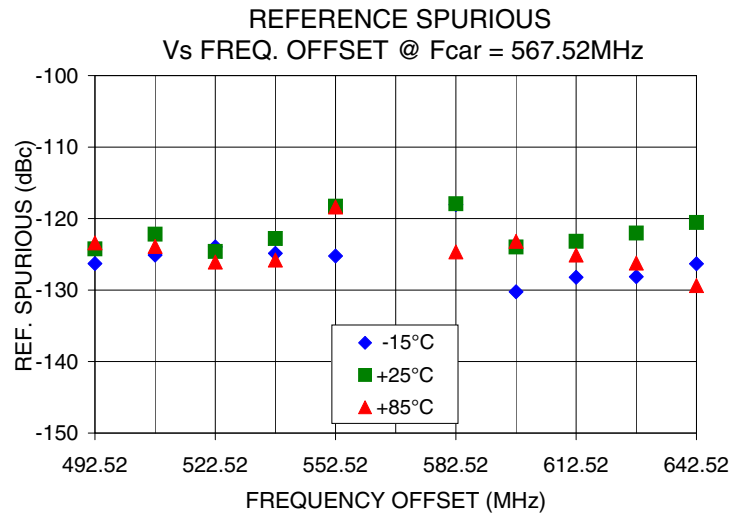
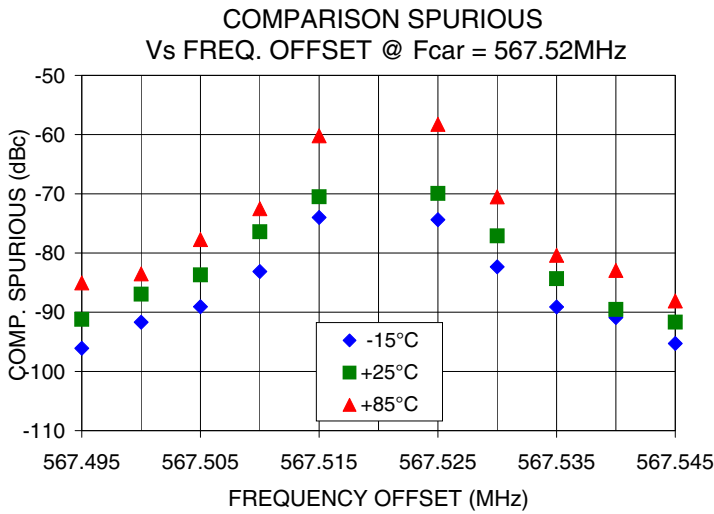

IF/RF MICROWAVE COMPONENTS • ISO 9001 ISO 14001 AS9100 CERTIFIED RoHS compliant
P.O. Box 350166, Brooklyn, New York 11235-0003 (718) 934-4500 Fax (718) 332-4661



The Design Engineers Search Engine finds the model you need, Instantly • For detailed performance specs & shopping online see



Notes: 1. Performance and quality attributes and conditions not expressly stated in this specification sheet are intended to be excluded and do not form a part of this specification sheet. 2. Electrical specifications and performance data contained herein are based on Mini-Circuit's applicable established test performance criteria and measurement instructions. 3. The parts covered by this specification sheet are subject to Mini-Circuits standard limited warranty and terms and conditions (collectively, "Standard Terms"); Purchasers of this part are entitled to the rights and benefits contained therein. For a full statement of the Standard Terms and the exclusive rights and remedies thereunder, please visit Mini-Circuits' website at www.minicircuits.com/MCLStore/terms.jsp.

Pin Configuration

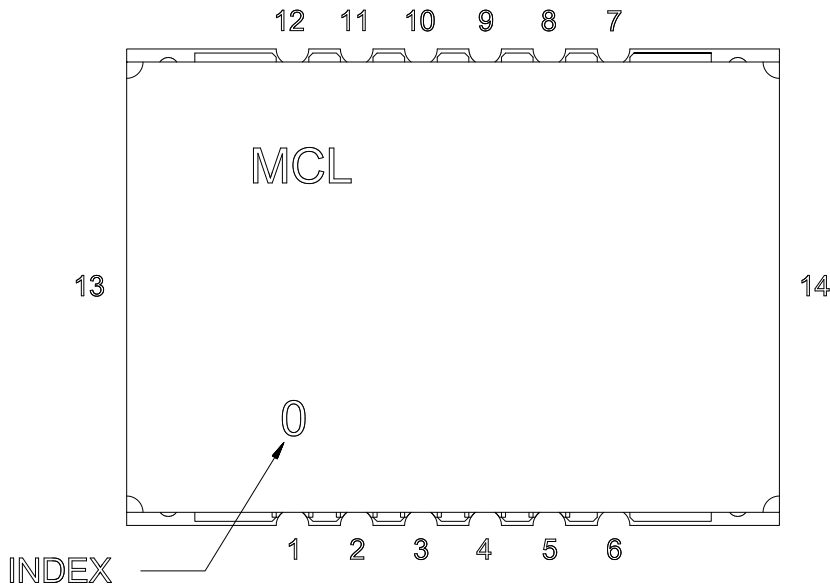

Pin Connection

Pin Number	Function
1	VCC PLL
2	GND
3	REF IN
4	GND
5	VCC VCO
6	GND
7	RF OUT
8	GND
9	LOCK DET
10	CLOCK
11	DATA
12	LE
13	GND
14	GND

Recommended Application Circuit

Note: REF IN and RF OUT ports are internally AC coupled.

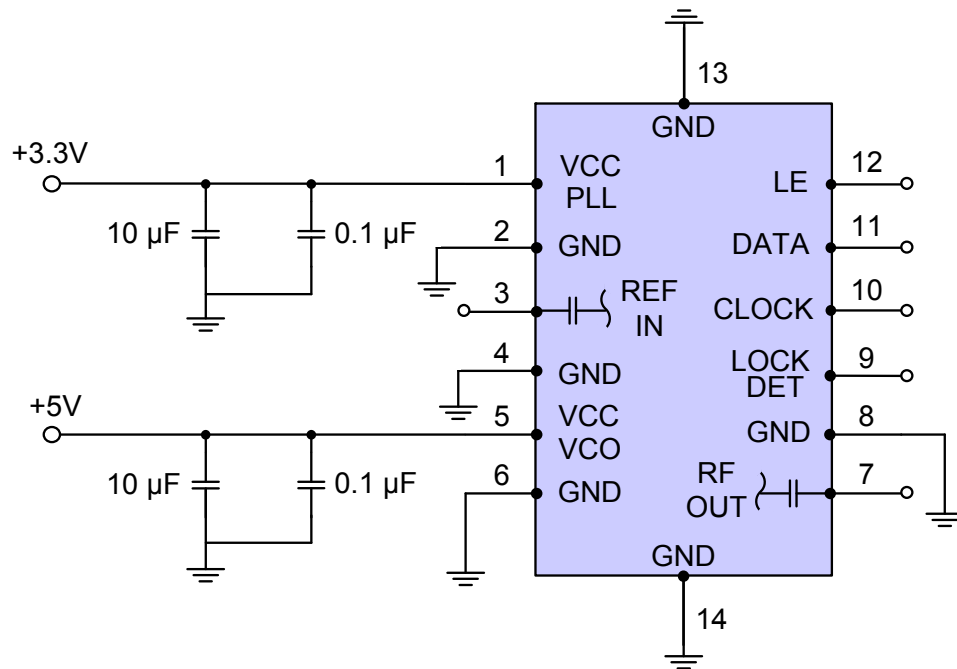

IF/RF MICROWAVE COMPONENTS • ISO 9001 ISO 14001 AS9100 CERTIFIED RoHS compliant
 P.O. Box 350166, Brooklyn, New York 11235-0003 (718) 934-4500 Fax (718) 332-4661



The Design Engineers Search Engine finds the model you need, Instantly • For detailed performance specs & shopping online see



Notes: 1. Performance and quality attributes and conditions not expressly stated in this specification sheet are intended to be excluded and do not form a part of this specification sheet. 2. Electrical specifications and performance data contained herein are based on Mini-Circuit's applicable established test performance criteria and measurement instructions. 3. The parts covered by this specification sheet are subject to Mini-Circuits standard limited warranty and terms and conditions (collectively, "Standard Terms"); Purchasers of this part are entitled to the rights and benefits contained therein. For a full statement of the Standard Terms and the exclusive rights and remedies thereunder, please visit Mini-Circuits' website at www.minicircuits.com/MCLStore/terms.jsp.

Device Marking

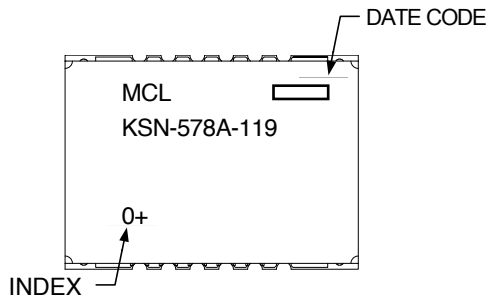
**Additional Detailed Technical Information**

Additional information is available on our web site. To access this information enter the model number on our web site home page.

Case Style: DK801

Tape & Reel: TR-F28

Suggested Layout for PCB Design: PL-249

Evaluation Board: TB-567-1+

Environment Ratings: ENV03T2



IF/RF MICROWAVE COMPONENTS • ISO 9001 ISO 14001 AS9100 CERTIFIED RoHS compliant
P.O. Box 350166, Brooklyn, New York 11235-0003 (718) 934-4500 Fax (718) 332-4661



The Design Engineers Search Engine finds the model you need, Instantly • For detailed performance specs & shopping online see minicircuits.com

Notes: 1. Performance and quality attributes and conditions not expressly stated in this specification sheet are intended to be excluded and do not form a part of this specification sheet. 2. Electrical specifications and performance data contained herein are based on Mini-Circuit's applicable established test performance criteria and measurement instructions. 3. The parts covered by this specification sheet are subject to Mini-Circuits standard limited warranty and terms and conditions (collectively, "Standard Terms"); Purchasers of this part are entitled to the rights and benefits contained therein. For a full statement of the Standard Terms and the exclusive rights and remedies thereunder, please visit Mini-Circuits' website at www.minicircuits.com/MCLStore/terms.jsp.