

# Coaxial High Isolation Switch

50Ω SPDT, TTL Driver, Reflective DC to 5000 MHz

## ZASW-2-50DR+



CASE STYLE: CY353

Connectors	Model	Price	Qty.
SMA	ZASW-2-50DR+	\$89.95	(1-9)

**+RoHS Compliant**

The +Suffix identifies RoHS Compliance. See our web site for RoHS Compliance methodologies and qualifications

### Maximum Ratings

Operating Temperature	-20°C to 85°C
Storage Temperature	-55°C to 150°C
Input Power	see Table & Note 2
Supply V	see Table
Permanent damage may occur if any of these limits are exceeded.	

### Coaxial Connections

RF IN	1
RF OUT 1	3
RF OUT 2	6
TTL IN	4
+5V	2
-5V	5

### Features

- wideband, DC to 5 GHz
- integral TTL driver
- high isolation, 82 dB typ. at 2 GHz

### Applications

- transmitter receiver isolation
- automated switching networks

### Electrical Specifications

FREQ. (MHz)	INSERTION LOSS (dB)						1dB COMPR. (dBm)				IN-OUT ISOLATION (dB)												
	DC-100 MHz		100-1000 MHz		1000-2000 MHz		2000-5000 MHz		DC-100 MHz		10-1000 MHz		1000-2000 MHz		2000-5000 MHz		DC-100 MHz		100-1000 MHz		1000-2000 MHz		2000-5000 MHz
f <sub>L</sub>	f <sub>U</sub>	Typ.	Max.	Typ.	Max.	Typ.	Max.	Typ.	Max.	Typ.	Typ.	Typ.	Typ.	Typ.	Min.	Typ.	Min.	Typ.	Min.	Typ.	Min.	Typ.	Min.
DC	5000	1.3	2.0	1.7	2.5	1.8	3.0	3.0	4.5	17	20	20	19	100	80	90	75	82	65	68	68	46	

### Outline Drawing

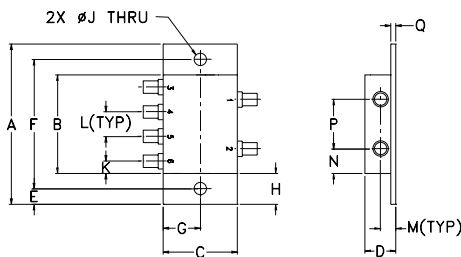

### Outline Dimensions (inch/mm)

A	B	C	D	E	F	G	H
3.24	2.00	1.50	.62	.31	2.620	.75	.62
82.30	50.80	38.10	15.75	7.87	66.55	19.05	15.75
J	K	L	M	N	P	Q	wt
.250	.25	.50	.31	.50	1.00	.13	grams
6.35	6.35	12.70	7.87	12.70	25.40	3.30	65.0

### Additional Specifications

Low Threshold, V	0 Min., 0.8 Max.
High Threshold, V	2 Min., 5 Max.
Control Current, mA	High V, 5 Max. Low V, 0.2 Max.
Positive Supply, V	+5±0.5/-0.1
Negative Supply, V	-5-0.5/+0.1
Positive Supply Current, mA	22 Typ., 60 Max.
Negative Supply Current, mA	22 Typ., 60 Max.
Video Leakage <sup>1</sup> , mVp-p	140 Typ.
RF Power Input <sup>2</sup>	250mW
VSWR (:1)	
ON, all ports	1.3 Typ.
OFF, Input	1.3 Typ.
OFF, Output	3.3 Typ.
Rise/Fall Time (10%-90%), ns	5 Typ., 15 Max.
Switching Time, 50% of control to 90% RF (Turn-on), ns	10 Typ., 20 Max.
10% RF (Turn-off), ns	10 Typ., 20 Max.

### CONTROL LOGIC

TTL Control Port	RF outputs	
	1	2
HIGH	OFF	ON
LOW	ON	OFF

1. Video leakage or break through is defined as leakage of TTL switching signal to RF output ports.
2. Above 20° derate power linearly to zero at 150°C
3. All RF connections must be DC blocked or held at 0V DC.

### Electrical Schematic

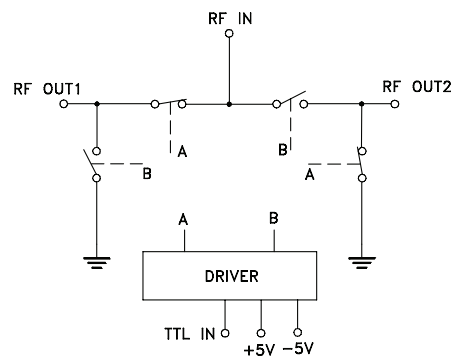

### Notes

- Performance and quality attributes and conditions not expressly stated in this specification document are intended to be excluded and do not form a part of this specification document.
- Electrical specifications and performance data contained in this specification document are based on Mini-Circuit's applicable established test performance criteria and measurement instructions.
- The parts covered by this specification document are subject to Mini-Circuits standard limited warranty and terms and conditions (collectively, "Standard Terms"); Purchasers of this part are entitled to the rights and benefits contained therein. For a full statement of the Standard Terms and the exclusive rights and remedies thereunder, please visit Mini-Circuits' website at [www.minicircuits.com/MCLStore/terms.jsp](http://www.minicircuits.com/MCLStore/terms.jsp)



## Typical Performance Data

FREQ. (MHz)	ON INSERTION LOSS (dB)		OFF ISOLATION (dB)		VSWR IN	VSWR ON	VSWR OUT
	$\bar{x}$	$\sigma$	$\bar{x}$	$\sigma$			
1.00	1.06	0.01	109.17	3.64	1.20	1.23	5.70
10.00	1.08	0.01	108.91	10.51	1.19	1.23	5.70
50.00	1.28	0.01	104.03	5.94	1.17	1.18	5.63
100.00	1.38	0.00	105.82	7.43	1.16	1.17	5.61
300.00	1.53	0.01	97.50	4.30	1.25	1.25	5.56
500.00	1.64	0.02	93.26	3.56	1.34	1.35	5.59
700.00	1.71	0.03	89.84	2.64	1.40	1.43	5.68
1000.00	1.80	0.05	86.55	2.68	1.37	1.42	5.89
1400.00	1.73	0.02	85.22	3.42	1.20	1.20	6.26
1800.00	1.83	0.07	80.22	1.20	1.13	1.09	6.68
2000.00	1.98	0.07	75.82	0.90	1.24	1.24	6.86
2400.00	2.15	0.06	70.36	0.67	1.39	1.38	7.25
2800.00	2.46	0.05	69.10	0.43	1.36	1.18	7.53
3000.00	2.60	0.13	68.74	0.75	1.34	1.17	7.53
3400.00	3.13	0.04	71.45	4.25	1.33	1.41	7.38
3600.00	2.96	0.08	76.78	3.43	1.36	1.53	7.28
4000.00	2.70	0.13	62.02	0.76	1.43	1.41	6.83
4500.00	2.55	0.17	55.47	0.73	1.43	1.36	5.87
4800.00	2.71	0.22	53.70	0.67	1.78	1.58	5.34
5000.00	2.90	0.16	53.70	0.76	1.85	1.68	4.99

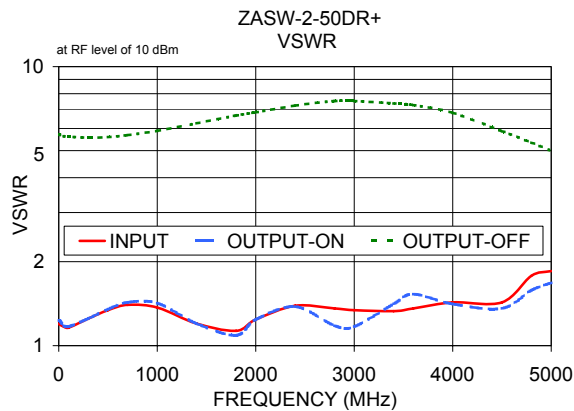
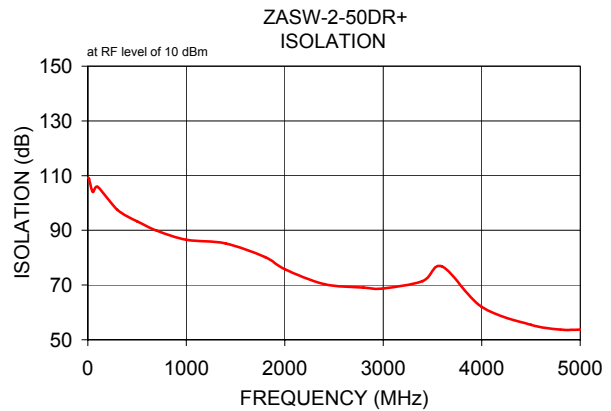
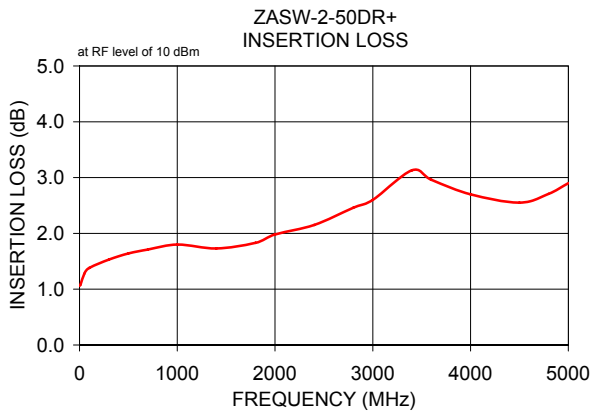

### Notes

- Performance and quality attributes and conditions not expressly stated in this specification document are intended to be excluded and do not form a part of this specification document.
- Electrical specifications and performance data contained in this specification document are based on Mini-Circuit's applicable established test performance criteria and measurement instructions.
- The parts covered by this specification document are subject to Mini-Circuits standard limited warranty and terms and conditions (collectively, "Standard Terms"); Purchasers of this part are entitled to the rights and benefits contained therein. For a full statement of the Standard Terms and the exclusive rights and remedies thereunder, please visit Mini-Circuits' website at [www.minicircuits.com/MCLStore/terms.jsp](http://www.minicircuits.com/MCLStore/terms.jsp)

