

Surface Mount Switch

50Ω Transfer, DC to 2.0 GHz Low Video Leakage

MSWT-4-20+



Maximum Ratings

Operating Temperature	-40°C to 85°C
Storage Temperature	-55°C to 100°C
Input Power	see Note 1
Control Current	see Note 2
Permanent damage may occur if any of these limits are exceeded.	

Pin Connections

Tx	2
Rx	6
J1	4
J2	8
CONTROL 1	1
CONTROL 2	3
CONTROL 3	5
CONTROL 4	7

Outline Drawing

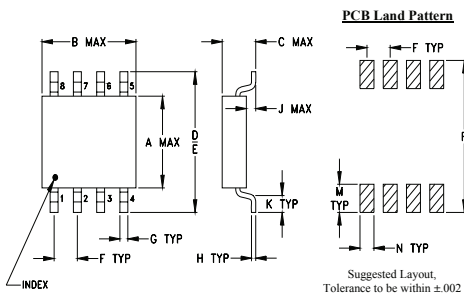

Outline Dimensions (inch/mm)

A	B	C	D	E	F	G
.163	.210	.077	.250	.220	.050	.017
4.14	5.33	1.96	6.35	5.59	1.27	0.43

H	J	K	M	N	P	wt
.009	.025	.030	.050	.030	.270	grams
0.23	0.64	0.76	1.27	0.76	6.86	0.10

Demo Board MCL P/N: TB-202 Suggested PCB Layout (PL-220)

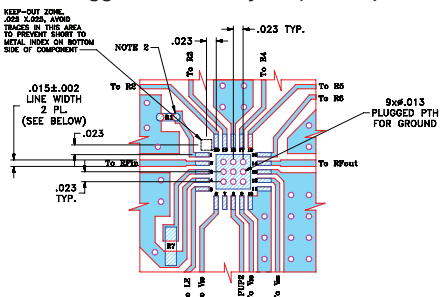

- NOTES**
- TRACE WIDTH IS SHOWN FOR FR4 WITH DIELECTRIC THICKNESS .002"±.001". COPPER 1/2 OZ. EACH SIDE. FOR OTHER MATERIALS TRACE WIDTH MAY NEED TO BE MODIFIED.
 - 0603, 0402 SIZES CHIP FOOT PRINTS SHOWN FOR REFERENCE. VALUES OF RESISTORS WILL VARY BASED ON APPLICATION.
 - BOTTOM SIDE OF THIS PCB IS CONTINUOUS GROUND PLANE.
- DENOTES PCB COPPER LAYOUT WITH SMOBC (SOLDER MASK OVER BARE COPPER)
- DENOTES COPPER LAND PATTERN FREE OF SOLDERMASK

Notes

- Performance and quality attributes and conditions not expressly stated in this specification document are intended to be excluded and do not form a part of this specification document.
- Electrical specifications and performance data contained in this specification document are based on Mini-Circuit's applicable established test performance criteria and measurement instructions.
- The parts covered by this specification document are subject to Mini-Circuits standard limited warranty and terms and conditions (collectively, "Standard Terms"); Purchasers of this part are entitled to the rights and benefits contained therein. For a full statement of the Standard Terms and the exclusive rights and remedies thereunder, please visit Mini-Circuits' website at www.minicircuits.com/MCLStore/terms.jsp

Features

- wideband, DC to 2.0 GHz
- low video leakage, 15 mVp-p typ.
- excellent VSWR, 1.2:1 typ.

CASE STYLE: XX211-1
PRICE: \$3.95 ea. QTY (10)

Applications

- transmitter/receiver
- automatic test equipment

+RoHS Compliant
The +Suffix identifies RoHS Compliance. See our web site for RoHS Compliance methodologies and qualifications

Electrical Specifications

FREQ. (GHz)	Path	INSERTION LOSS (dB)								1dB COMPR. (dBm)				ISOLATION (dB)							
		DC-100 MHz		100-500 MHz		500-1000 MHz		1000-2000 MHz		DC-100 MHz		100-500 MHz		500-1000 MHz		1000-2000 MHz					
		Typ.	Max.	Typ.	Max.	Typ.	Max.	Typ.	Max.	Typ.	Min.	Typ.	Min.	Typ.	Min.	Typ.	Min.				
DC	Tx-J1/J2	0.9	1.2	1.1	1.5	1.25	1.8	1.45	2.2	18	25	28	29	51	44	34	27	26	21	19	15
	J1/J2-Rx	1.1	1.4	1.3	1.7	1.5	2.0	1.6	2.2	16	18	20	22	52	46	37	31	29	24	21	17
	Tx-Rx	—	—	—	—	—	—	—	—	—	—	—	—	—	60	53	41	36	34	27	28

Additional Specifications

Control Current, mA	0.2 max to -8V, 0.02 max at 0 to -0.2V				
VSWR(:1)	DC-.1GHz 1.2 typ. 1.65 max.	.1-.5GHz 1.25 typ. 1.8 max.	.5-1GHz 1.4 typ. 1.9 max.	1-2GHz 1.4 typ. 1.7 max.	
Rise/Fall time (10%-90%), ns	2 typ.				
Switching time, 50% of Control to 90% RF (Turn-on), ns	4 typ				
10% RF (Turn-off), ns	4 typ				
**Video Leakage, mVp-p 0/-5V Control	15 typ.				

- ** Video leakage or break through is defined as leakage of switching signal to RF output ports.
- RF Power Input (dBm), Max.

DC-100MHz	100-500 MHz	500-2000MHz
24	27	33

 - Steady State Control 0/-8V
 - As a Modulator
 - Control Current, 500µA (occurs at -9V to -12V typ.)

24	27	33
12	17	23

Control Ports				"On" Path (other paths are "OFF")
1	2	3	4	
0	-v	-v	-v	T _x -J ₂
-v	0	-v	-v	T _x -J ₁
-v	-v	0	-v	R _x -J ₁
-v	-v	-v	0	R _x -J ₂
0	-v	0	-v	T _x -J ₂ & R _x -J ₁
-v	0	-v	0	T _x -J ₁ & R _x -J ₂

Application Note for MSWT-4-20 Transmit-Receive Switch:

The functional schematic diagram for a diversity application of the switch is shown in Figure 1, with the required external components including 4 independent drivers at the control ports. When operation as a transfer switch is desired only 2 drivers are needed, one connected to the V1 and V3 ports together, and the other connected to the V2 and V4 ports. In either case, two DC return paths are needed for the control voltages, represented by the ground symbols in the diagram. These returns must be via oppositely situated RF ports (Tx and Rx or J1 and J2), and can be furnished incidentally by the user's RF terminating devices themselves. However, if those devices are AC-coupled (that is, they contain DC blocking capacitors), then the shunt resistors shown in the diagram are needed. The resistor should be installed either at the Tx and Rx ports (connection shown as solid), or at J1 and J2 (shown dotted), with equal effect. If one external RF device has a DC return to ground, for example, then only one resistor is needed; it must be installed at the opposite RF port of the switch. The resistance of each of the external DC returns should be 20K ohms or less, for proper ON/OFF FETs.

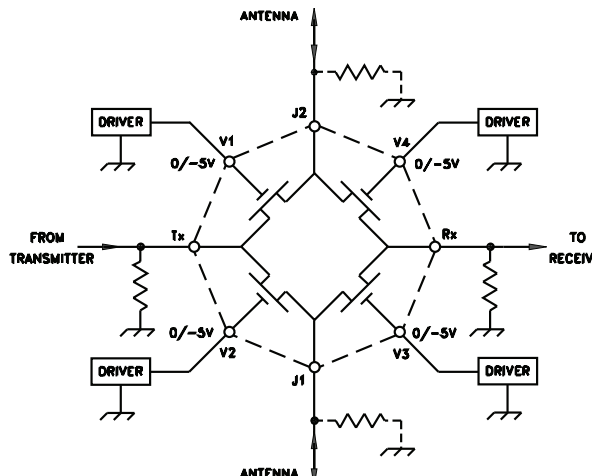
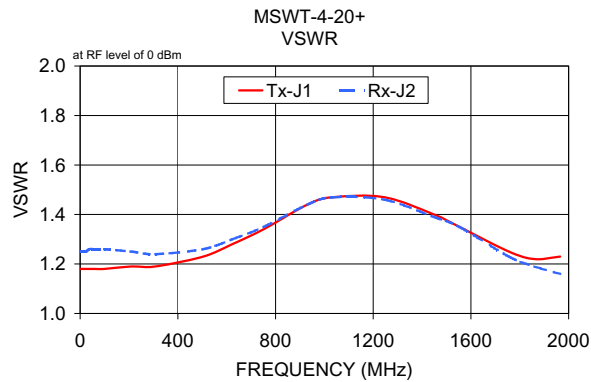
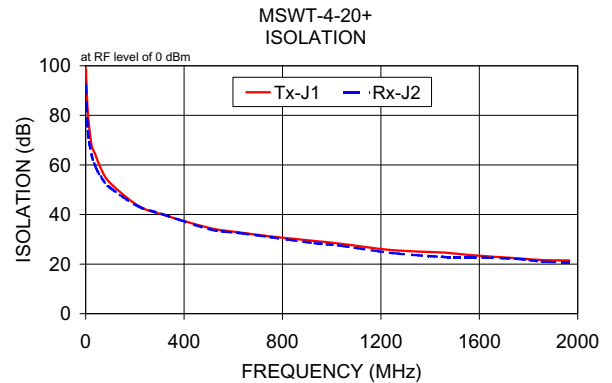
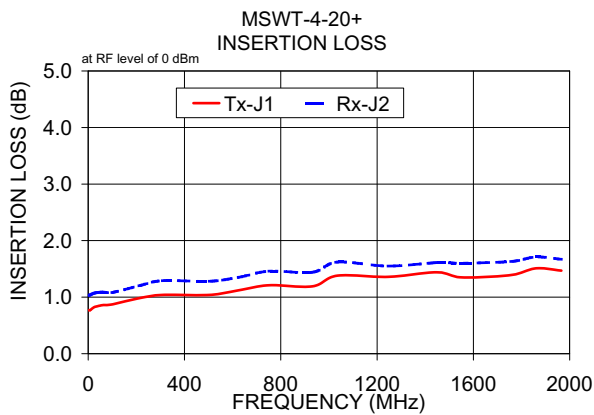

Figure 1. Functional Schematic Diagram



Typical Performance Data

FREQ. (MHz)	ON INSERTION LOSS (dB) (CTRL ₁ @-8V, CTRL ₂ @0V) (CTRL ₃ @-8V, CTRL ₄ @0V)				AMPLITUDE UNBALANCE				OFF ISOLATION (dB) (CTRL ₁ @0V, CTRL ₂ @-8V) (CTRL ₃ @0V, CTRL ₄ @-8V)				VSWR ON	
	Tx-J ₁		Rx-J ₂						Tx-J ₁		Rx-J ₂			
	\bar{x}	σ	\bar{x}	σ	\bar{x}	σ	\bar{x}	σ	\bar{x}	σ	\bar{x}	σ	$\frac{T_{x-J_1}}{\bar{x}}$	$\frac{R_{x-J_2}}{\bar{x}}$
1.00	0.77	0.01	1.03	0.02	0.27	0.03	98.89	2.58	92.52	7.65	1.18	1.25		
8.49	0.77	0.01	1.04	0.02	0.27	0.03	81.64	2.04	73.58	0.79	1.18	1.25		
23.49	0.82	0.01	1.07	0.02	0.25	0.02	68.21	1.03	64.25	0.16	1.18	1.25		
38.48	0.84	0.02	1.08	0.01	0.24	0.01	64.34	0.08	59.52	0.25	1.18	1.26		
60.98	0.86	0.04	1.09	0.01	0.23	0.00	58.77	0.40	55.31	0.17	1.18	1.26		
98.46	0.87	0.01	1.08	0.02	0.21	0.02	52.85	0.01	50.90	0.08	1.18	1.26		
210.93	0.98	0.01	1.20	0.02	0.22	0.03	43.69	0.14	43.46	0.31	1.19	1.25		
308.39	1.04	0.03	1.29	0.01	0.25	0.01	40.09	0.12	40.29	0.05	1.19	1.24		
503.33	1.04	0.04	1.28	0.02	0.25	0.01	34.58	0.17	34.09	0.32	1.23	1.26		
623.29	1.12	0.03	1.35	0.02	0.25	0.02	32.82	0.07	32.54	0.08	1.28	1.30		
750.75	1.21	0.04	1.46	0.02	0.25	0.02	31.17	0.06	30.89	0.08	1.34	1.35		
930.69	1.19	0.03	1.44	0.02	0.28	0.02	29.33	0.09	28.45	0.21	1.44	1.44		
1035.65	1.38	0.03	1.62	0.02	0.26	0.03	28.25	0.16	27.42	0.11	1.47	1.47		
1245.58	1.36	0.03	1.55	0.02	0.22	0.05	25.64	0.15	24.47	0.09	1.47	1.46		
1448.01	1.44	0.02	1.61	0.01	0.24	0.05	24.70	0.15	22.92	0.24	1.40	1.39		
1552.98	1.35	0.01	1.60	0.02	0.28	0.02	23.72	0.06	22.75	0.12	1.35	1.35		
1755.41	1.39	0.03	1.63	0.02	0.24	0.03	22.32	0.11	22.09	0.15	1.25	1.23		
1860.38	1.51	0.02	1.71	0.02	0.22	0.02	21.60	0.13	20.95	0.12	1.22	1.19		
1965.34	1.47	0.04	1.67	0.01	0.22	0.06	21.50	0.19	20.84	0.12	1.23	1.16		



Notes

- Performance and quality attributes and conditions not expressly stated in this specification document are intended to be excluded and do not form a part of this specification document.
- Electrical specifications and performance data contained in this specification document are based on Mini-Circuits' applicable established test performance criteria and measurement instructions.
- The parts covered by this specification document are subject to Mini-Circuits standard limited warranty and terms and conditions (collectively, "Standard Terms"); Purchasers of this part are entitled to the rights and benefits contained therein. For a full statement of the Standard Terms and the exclusive rights and remedies thereunder, please visit Mini-Circuits' website at www.minicircuits.com/MCLStore/terms.jsp Page 2 of 2

