

Coaxial Power Splitter/Combiner

4 Way-0° 50Ω 850 to 930 MHz

ZB4PD1-930+ ZB4PD1-930



SMA version shown
CASE STYLE: UU188

Connectors	Model	Price	Qty.
SMA	ZB4PD1-930-S(+)	\$99.95	(1-9)
N-TYPE	ZB4PD1-930-N(+)	\$99.95	(1-9)

+ RoHS compliant in accordance with EU Directive (2002/95/EC)

The +Suffix identifies RoHS Compliance. See our web site for RoHS Compliance methodologies and qualifications.

Maximum Ratings

Operating Temperature	-55°C to 100°C
Storage Temperature	-55°C to 100°C
Power Input (as a splitter)	10W max.
Internal Dissipation	0.375W max.

Permanent damage may occur if any of these limits are exceeded.

Coaxial Connections

SUM PORT	S
PORT 1	1
PORT 2	2
PORT 3	3
PORT 4	4

Features

- high isolation, 30 dB typ.
- rugged shielded case
- very good VSWR, 1.10:1 typ.
- up to 10W power input as a splitter

Applications

- cellular
- communication systems
- receivers/transmitters

Electrical Specifications

FREQ. RANGE (MHz)	ISOLATION (dB)		INSERTION LOSS (dB) ABOVE 6.0 dB		PHASE UNBALANCE (Degrees)	AMPLITUDE UNBALANCE (dB)	VSWR (:1)			
	Typ.	Min.	Typ.	Max.			S		OUT	
f_L - f_U					Max.	Max.	Typ.	Max.	Typ.	Max.
850-930	30	20	0.3	0.5	5	0.25	1.10	1.25	1.09	1.25

Outline Drawing

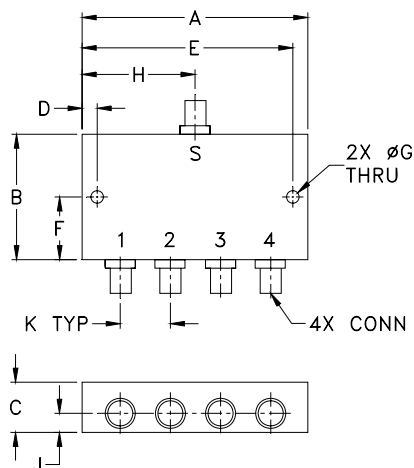

Outline Dimensions (inch/mm)

A	B	C	D	E	F
3.50	2.13	.88	.150	3.350	1.06
88.90	54.10	22.35	3.81	85.09	26.92
G	H	J	K		wt
.125	1.75	.44	.89		grams
3.18	44.45	11.18	22.61		260

Typical Performance Data

Freq. (MHz)	Total Loss ¹ (dB)				Amp. Unbal. (dB)	Isolation (dB)			VSWR				
	S-1	S-2	S-3	S-4		1-2	2-3	3-4	S	1	2	3	4
850.00	6.14	6.11	6.10	6.13	0.04	28.39	33.26	27.78	1.01	1.10	1.06	1.06	1.10
857.44	6.13	6.09	6.10	6.09	0.04	29.23	34.16	28.57	1.01	1.10	1.06	1.06	1.10
862.31	6.16	6.12	6.11	6.12	0.05	29.70	34.73	28.96	1.02	1.10	1.06	1.05	1.10
867.19	6.12	6.10	6.11	6.09	0.04	30.23	35.31	29.44	1.02	1.09	1.06	1.05	1.09
876.94	6.15	6.12	6.13	6.11	0.03	30.97	36.38	30.21	1.03	1.09	1.05	1.04	1.09
885.06	6.10	6.09	6.08	6.08	0.03	31.29	36.88	30.57	1.04	1.09	1.05	1.04	1.09
886.69	6.13	6.10	6.09	6.09	0.04	31.31	37.08	30.60	1.04	1.09	1.05	1.04	1.09
891.56	6.10	6.09	6.08	6.07	0.03	31.38	37.36	30.70	1.04	1.08	1.04	1.04	1.08
899.69	6.09	6.08	6.08	6.06	0.03	31.11	37.41	30.49	1.05	1.08	1.04	1.03	1.08
907.00	6.08	6.08	6.07	6.05	0.03	30.52	37.21	30.02	1.06	1.08	1.04	1.03	1.08
911.88	6.06	6.06	6.08	6.06	0.02	30.19	36.93	29.68	1.07	1.08	1.03	1.03	1.08
920.00	6.06	6.07	6.07	6.04	0.03	29.34	36.13	28.90	1.08	1.07	1.03	1.03	1.07
924.88	6.06	6.07	6.09	6.04	0.05	28.82	35.64	28.37	1.09	1.07	1.03	1.03	1.07
927.31	6.07	6.05	6.06	6.03	0.04	28.52	35.30	28.12	1.09	1.07	1.03	1.03	1.07
930.00	6.06	6.07	6.07	6.03	0.05	28.22	35.11	27.88	1.10	1.07	1.03	1.03	1.07

1. Total Loss = Insertion Loss + 6dB splitter loss.

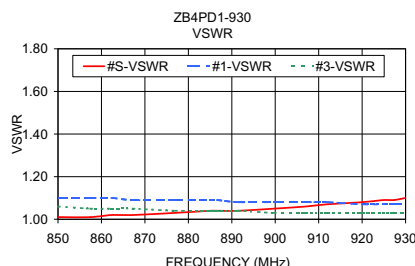
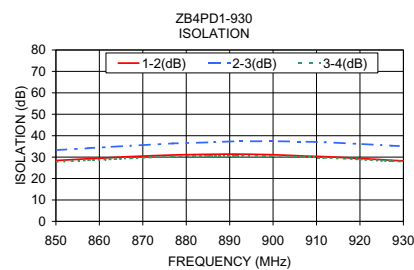
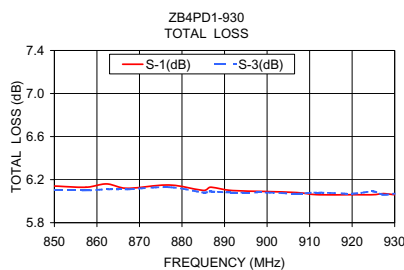

electrical schematic



Mini-Circuits®
ISO 9001 ISO 14001 AS 9100 CERTIFIED
The Design Engineers Search Engine **360°** Provides ACTUAL Data Instantly at minicircuits.com
IF/RF MICROWAVE COMPONENTS

For detailed performance specs & shopping online see web site

P.O. Box 350166, Brooklyn, New York 11235-0003 (718) 934-4500 Fax (718) 332-4661

Notes: 1. Performance and quality attributes and conditions not expressly stated in this specification sheet are intended to be excluded and do not form a part of this specification sheet. 2. Electrical specifications and performance data contained herein are based on Mini-Circuit's applicable established test performance criteria and measurement instructions. 3. The parts covered by this specification sheet are subject to Mini-Circuits standard limited warranty and terms and conditions (collectively, "Standard Terms"); Purchasers of this part are entitled to the rights and benefits contained therein. For a full statement of the Standard Terms and the exclusive rights and remedies thereunder, please visit Mini-Circuits' website at www.minicircuits.com/MCLStore/terms.jsp.

REV. D
M127604
ZB4PD1-930
HY/TD/CP/AM
100617