

Coaxial Power Splitter/Combiner

ZB4PD1-32-75+

4 Way-0° 75Ω 0.25 to 300 MHz



CASE STYLE: UU188

Connectors	Model	Price	Qty.
BNC	ZB4PD1-32-75+	\$89.95 ea.	(1-9)

+ RoHS compliant in accordance with EU Directive (2002/95/EC)

The +Suffix identifies RoHS Compliance. See our web site for RoHS Compliance methodologies and qualifications.

Maximum Ratings

Operating Temperature	-55°C to 100°C
Storage Temperature	-55°C to 100°C
Power Input (as a splitter)	1W max.
Internal Dissipation	0.250W max.

Permanent damage may occur if any of these limits are exceeded.

Coaxial Connections

SUM PORT	S
PORT 1	1
PORT 2	2
PORT 3	3
PORT 4	4

Features

- wideband, 0.25 to 300 MHz
- high isolation, 36 dB typ.
- excellent amplitude unbalance, 0.05 dB typ.
- excellent phase unbalance, 0.5 deg. typ.
- rugged, shielded case

Applications

- VHF/UHF
- radio communication

Electrical Specifications

FREQ. RANGE (MHz)	ISOLATION (dB)						INSERTION LOSS (dB) ABOVE 6.0 dB						PHASE UNBALANCE (Degrees)			AMPLITUDE UNBALANCE (dB)		
	L		M		U		L		M		U		L	M	U	L	M	U
	Typ.	Min.	Typ.	Min.	Typ.	Min.	Typ.	Max.	Typ.	Max.	Typ.	Max.	Max.	Max.	Max.	Max.	Max.	Max.
0.25-300	34	20	36	25	28	22	0.2	0.6	0.3	0.6	0.5	1.0	1	2	3	0.15	0.20	0.25

L = low range [f_L to $10 f_L$] M = mid range [$10 f_L$ to $f_U/2$] U = upper range [$f_U/2$ to f_U]

Typical Performance Data

Freq. (MHz)	Total Loss ¹ (dB)				Amp. Unbal. (dB)	Isolation (dB)			Phase Unbal. (deg.)	VSWR	VSWR	VSWR	VSWR	VSWR
	S-1	S-2	S-3	S-4		1-2	2-3	3-4		S	1	2	3	4
0.25	6.21	6.21	6.21	6.20	0.01	31.09	62.13	32.62	0.02	1.10	1.16	1.16	1.15	1.15
1.00	6.18	6.17	6.18	6.17	0.01	37.39	61.06	37.94	0.03	1.04	1.07	1.07	1.07	1.07
2.50	6.15	6.14	6.15	6.14	0.01	40.66	58.82	41.03	0.02	1.10	1.16	1.16	1.15	1.15
10.00	6.16	6.15	6.16	6.16	0.01	41.88	51.47	41.75	0.02	1.02	1.03	1.03	1.03	1.03
40.00	6.22	6.22	6.23	6.22	0.01	37.93	41.96	37.69	0.09	1.01	1.04	1.04	1.04	1.04
60.00	6.26	6.25	6.26	6.25	0.01	35.92	39.03	35.69	0.13	1.01	1.06	1.06	1.06	1.06
80.00	6.29	6.28	6.29	6.28	0.01	34.47	36.97	34.22	0.17	1.01	1.08	1.07	1.07	1.07
100.00	6.32	6.31	6.32	6.31	0.01	33.37	35.36	33.09	0.21	1.01	1.09	1.09	1.09	1.09
150.00	6.39	6.38	6.39	6.38	0.01	31.11	32.52	30.80	0.31	1.02	1.15	1.14	1.14	1.14
200.00	6.46	6.46	6.47	6.45	0.02	29.83	30.59	29.42	0.42	1.04	1.20	1.20	1.20	1.20
220.00	6.49	6.49	6.50	6.48	0.02	29.19	29.99	28.74	0.46	1.05	1.23	1.22	1.22	1.22
240.00	6.52	6.52	6.53	6.50	0.02	28.69	29.45	28.20	0.52	1.06	1.25	1.24	1.24	1.24
260.00	6.55	6.55	6.56	6.53	0.03	28.31	29.00	27.76	0.55	1.08	1.28	1.26	1.27	1.26
280.00	6.58	6.58	6.59	6.56	0.03	27.84	28.58	27.24	0.56	1.09	1.30	1.29	1.29	1.28
300.00	6.62	6.62	6.63	6.60	0.03	27.21	28.21	26.56	0.60	1.10	1.32	1.31	1.31	1.31

1. Total Loss = Insertion Loss + 6dB splitter loss.

Outline Drawing

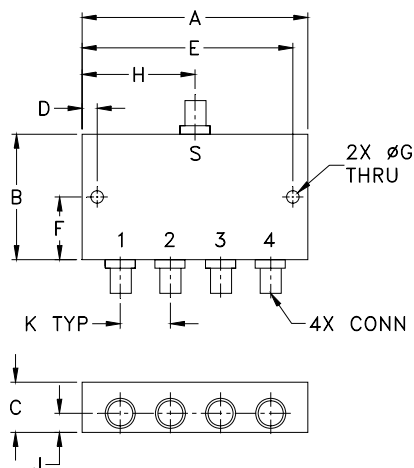

Outline Dimensions (inch/mm)

A	B	C	D	E	F	
3.50	2.13	.88	.150	3.350	1.06	
88.90	54.10	22.35	3.81	85.09	26.92	
G	H	J	K			wt
.125	1.75	.44	.89			grams
3.18	44.45	11.18	22.61			260

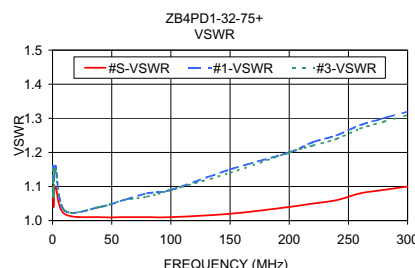
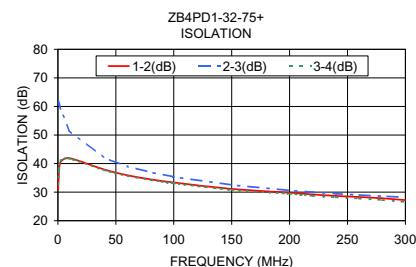
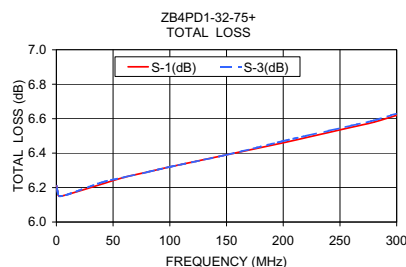

electrical schematic



Mini-Circuits
 ISO 9001 ISO 14001 AS 9100 CERTIFIED
 IFIRF MICROWAVE COMPONENTS

For detailed performance specs & shopping online see web site

P.O. Box 350166, Brooklyn, New York 11235-0003 (718) 934-4500 Fax (718) 332-4661 The Design Engineers Search Engine Provides ACTUAL Data Instantly at minicircuits.com

Notes: 1. Performance and quality attributes and conditions not expressly stated in this specification sheet are intended to be excluded and do not form a part of this specification sheet. 2. Electrical specifications and performance data contained herein are based on Mini-Circuit's applicable established test performance criteria and measurement instructions. 3. The parts covered by this specification sheet are subject to Mini-Circuits standard limited warranty and terms and conditions (collectively, "Standard Terms"); Purchasers of this part are entitled to the rights and benefits contained therein. For a full statement of the Standard Terms and the exclusive rights and remedies thereunder, please visit Mini-Circuits' website at www.minicircuits.com/MCLStore/terms.jsp.

REV. A
 M127604
 ZB4PD1-32-75+
 ED-13159/1
 HY/CP
 100617