

Power Splitter/Combiner

SCPJ-2-750-75

2 Way-180° 75Ω

30 to 750 MHz



CASE STYLE: YY161
PRICE: \$27.95 ea. QTY (1-9)

Maximum Ratings

Operating Temperature	-40°C to 85°C
Storage Temperature	-55°C to 100°C
Power Input (as a splitter)	0.5W max.
Internal Dissipation	0.125W max.

Permanent damage may occur if any of these limits are exceeded.

Pin Connections

SUM PORT	1
PORT 1	5
PORT 2	6
GROUND	2,3,4,7,8

Features

- wideband, 30 to 750 MHz
- good isolation, 26 dB typ.

Applications

- catv
- VHF/UHF
- communication systems
- instrumentation

Electrical Specifications

FREQ. RANGE (MHz)	ISOLATION (dB)		INSERTION LOSS (dB) ABOVE 3 dB		PHASE UNBALANCE (Degrees)		AMPLITUDE UNBALANCE (dB)					
	L	U	L	U	L	U	L	U				
f_L - f_U	Typ. Min.	Typ. Min.	Typ. Max.	Typ. Max.	Max.	Max.	Max.	Max.				
30-750	26	20	26	16	1.0	1.5	1.5	2.2	3	6	0.8	0.9

L = 30-375 MHz U = 375-750 MHz

Outline Drawing

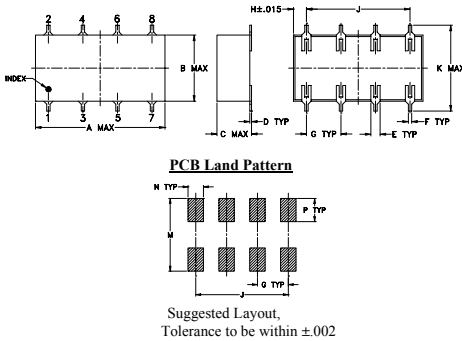

Outline Dimensions (inch/mm)

A	B	C	D	E	F	G
0.75	0.38	0.28	0.01	0.05	0.02	0.2
19.05	9.65	7.11	0.25	1.27	0.51	5.08
H	J	K	M	N	P	wt
0.075	0.6	0.45	0.47	0.1	0.15	grams
1.91	15.24	11.43	11.94	2.54	3.81	1.60

Demo Board MCL P/N: TB-228 Suggested PCB Layout (PL-121)

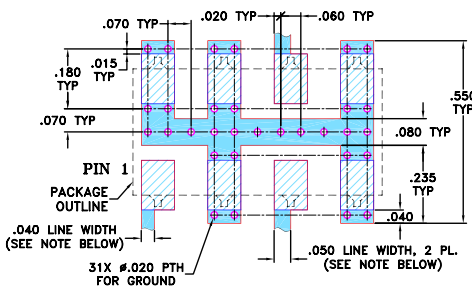

Typical Performance Data

Frequency (MHz)	Total Loss ¹ (dB) S-1	Total Loss ¹ (dB) S-2	Amplitude Unbalance (dB)	Isolation (dB)	Phase Unbalance (deg.)	VSWR S	VSWR 1	VSWR 2
30.00	3.77	3.42	0.35	25.15	180.09	1.10	1.33	1.22
50.00	3.81	3.43	0.38	25.30	179.80	1.11	1.32	1.23
70.00	3.85	3.47	0.37	25.47	179.88	1.14	1.32	1.23
100.00	3.86	3.49	0.38	25.71	179.87	1.16	1.31	1.23
130.00	3.90	3.52	0.37	26.00	179.90	1.19	1.31	1.24
160.00	3.93	3.59	0.34	26.24	179.73	1.24	1.30	1.25
190.00	3.90	3.60	0.30	26.57	179.80	1.27	1.30	1.27
225.00	3.96	3.67	0.28	27.10	179.88	1.31	1.29	1.28
300.00	3.97	3.74	0.23	28.64	179.93	1.37	1.28	1.32
375.00	3.93	3.85	0.08	31.07	180.00	1.37	1.27	1.33
450.00	3.94	3.94	0.00	33.29	180.35	1.34	1.23	1.31
550.00	3.99	4.12	0.13	29.25	180.70	1.27	1.16	1.24
650.00	4.04	4.32	0.28	23.86	181.54	1.22	1.09	1.14
700.00	4.09	4.44	0.35	21.79	177.84	1.25	1.09	1.09
750.00	4.15	4.57	0.42	20.16	177.24	1.31	1.11	1.05

1. Total Loss = Insertion Loss + 3dB splitter loss.

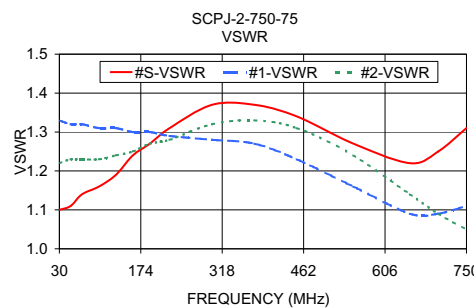
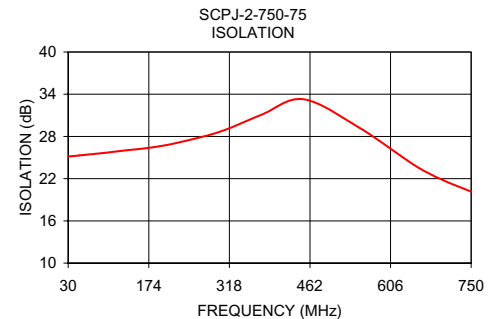
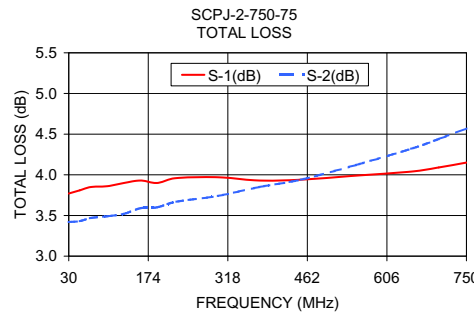

electrical schematic

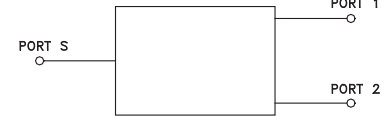

Mini-Circuits®
ISO 9001 ISO 14001 AS 9100 CERTIFIED

P.O. Box 350166, Brooklyn, New York 11235-0003 (718) 934-4500 Fax (718) 332-4661 The Design Engineers Search Engine Provides ACTUAL Data Instantly at minicircuits.com

IF/RF MICROWAVE COMPONENTS

For detailed performance specs & shopping online see web site

Notes: 1. Performance and quality attributes and conditions not expressly stated in this specification sheet are intended to be excluded and do not form a part of this specification sheet. 2. Electrical specifications and performance data contained herein are based on Mini-Circuit's applicable established test performance criteria and measurement instructions. 3. The parts covered by this specification sheet are subject to Mini-Circuits standard limited warranty and terms and conditions (collectively, "Standard Terms"); Purchasers of this part are entitled to the rights and benefits contained therein. For a full statement of the Standard Terms and the exclusive rights and remedies thereunder, please visit Mini-Circuits' website at www.minicircuits.com/MCLStore/terms.jsp.

REV. B
M127604
SCPJ-2-750-75
HY/TD/CP/AM
100621