

# USB Smart Power Sensor

## PWR-6GHS

50Ω -30 dBm to +20 dBm, 1MHz to 6000 MHz

### The Big Deal

- Low cost
- USB HID device compatible with 32/64 Bit operating systems
- Includes “Measurement Application” GUI (Graphical User Interface) software with an API-DLL com object
- High speed measurement capability



CASE STYLE: JL1504



### Product Overview

The Mini-Circuits PWR-6GHS Smart Power Sensor is a pocket-sized, 4.89” x 1.74” x 0.95”, precision test USB HID device (no driver installation required) that turns a Windows® or Linux® PC into a power meter. All specifications provided in the data sheet apply to continuous wave (CW) signals. Each unit is shipped with our N-to-SMA adapter and a quick-locking USB cable for reliable connectivity. Native software and detailed user guides are provided on the included CD, or can be downloaded from [minicircuits.com](http://minicircuits.com) anywhere an internet connection is available, providing a full range of data analysis options.

### Key Features

Feature	Advantages
USB HID (Human Interface Device)	Plug-and-Play (no need to install driver for the device).
GUI Measurement Application Software built-in	Enables the user to perform measurements on RF components such as Couplers, Filters, Amplifiers etc. and displays numerical data and graphs .
32/64 Bit operating systems	Compatible with Windows® and Linux® operating systems.
No calibration required before taking measurement	The PWR-6GHS does not require any reference signal for calibration.



For detailed performance specs & shopping online see web site

P.O. Box 350166, Brooklyn, New York 11235-0003 (718) 934-4500 Fax (718) 332-4661 [The Design Engineers Search Engine](http://www.minicircuits.com) Provides ACTUAL Data Instantly at [minicircuits.com](http://minicircuits.com)

IF/RF MICROWAVE COMPONENTS

Notes: 1. Performance and quality attributes and conditions not expressly stated in this specification sheet are intended to be excluded and do not form a part of this specification sheet. 2. Electrical specifications and performance data contained herein are based on Mini-Circuit's applicable established test performance criteria and measurement instructions. 3. The parts covered by this specification sheet are subject to Mini-Circuits standard limited warranty and terms and conditions (collectively, "Standard Terms"); Purchasers of this part are entitled to the rights and benefits contained therein. For a full statement of the Standard Terms and the exclusive rights and remedies thereunder, please visit Mini-Circuits' website at [www.minicircuits.com/MCLStore/terms.jsp](http://www.minicircuits.com/MCLStore/terms.jsp). Page 1 of 5

# USB Smart Power Sensor

PWR-6GHS

50Ω 1 MHz to 6000 MHz

### Product Features

- Wide bandwidth, 1 to 6000 MHz
- 50 dB Dynamic Range, -30 to +20 dBm
- Good VSWR, 1.1:1 typ.
- Fast measurement speed, 30 msec typ.
- Automatic frequency calibration & temperature compensation
- Multi-sensor capability (up to 24)
- Built in Application Measurement Software
- Remote operation via internet
- Effective, easy-to-use Windows® GUI
- Compatible with 32/64-bit Windows® or Linux® operating systems
- ActiveX com object and .Net class library for use with other software: C++, C#, CVI®, Delphi®, LabVIEW® 8 or newer, MATLAB® 7 or newer, Python, Agilent VEE®, Visual Basic®, Visual Studio® 6 or newer, and more<sup>1</sup>



Case Style: JL1504

Model No.	Description	Price	Qty.
<b>PWR-6GHS</b>	<b>USB smart Power Sensor</b>	\$695.00 ea.	(1-4)
<b>Included Accessories</b>			
PWR-SEN-6GHS	Power Sensor Head		
USB-CBL+	6 ft data cable (USB TType-A Plug)		1
NF-SM50+	N-Type (F) to SMA(M) Adapter		1
PWR-SEN-CD	Installation CD		1

### Typical Applications

- Turn almost any Windows or Linux PC into a Power Meter
- Pocket-sized portability for benchtop testing anywhere
- Remote location monitoring
- Automatic, scheduled data collection
- Evaluate high-power, multi-port devices with built-in virtual couplers/attenuators & other software tools

**RoHS Compliant**  
See our web site for RoHS Compliance methodologies and qualifications

### Mini-Circuits Power Meter Program for Smart USB Power Sensor

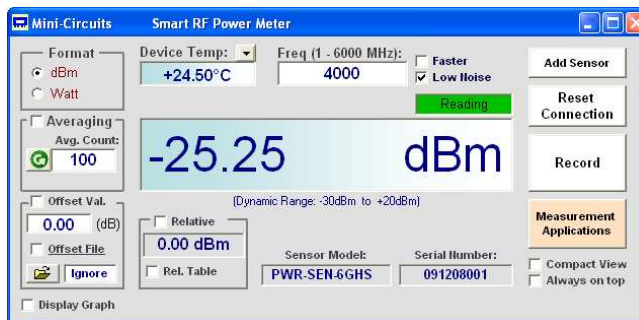

<sup>1</sup> Windows, Visual Basic, and Visual Studio are registered trademarks of Microsoft Corporation in the United States and other countries. Linux is a registered trademark of Linus Torvalds. LabVIEW and CVI are registered trademarks of National Instruments Corp. Delphi is a registered trademark of Codegear LLC. MATLAB is a registered trademark of MathWorks, Inc. Agilent VEE is a registered trademark of Agilent Technologies, Inc. Neither Mini-Circuits nor the Mini-Circuits PWR-6GHS are affiliated with or endorsed by the owners of the above referenced trademarks.

Mini-Circuits and the Mini-Circuits logo are registered trademarks of Scientific Components Corporation.



For detailed performance specs & shopping online see web site

P.O. Box 350166, Brooklyn, New York 11235-0003 (718) 934-4500 Fax (718) 332-4661 *The Design Engineers Search Engine* Provides ACTUAL Data Instantly at [minicircuits.com](http://minicircuits.com)

**Notes:** 1. Performance and quality attributes and conditions not expressly stated in this specification sheet are intended to be excluded and do not form a part of this specification sheet. 2. Electrical specifications and performance data contained herein are based on Mini-Circuit's applicable established test performance criteria and measurement instructions. 3. The parts covered by this specification sheet are subject to Mini-Circuits standard limited warranty and terms and conditions (collectively, "Standard Terms"); Purchasers of this part are entitled to the rights and benefits contained therein. For a full statement of the Standard Terms and the exclusive rights and remedies thereunder, please visit Mini-Circuits' website at [www.minicircuits.com/MCLStore/terms.jsp](http://www.minicircuits.com/MCLStore/terms.jsp).

## Electrical Specifications (CW)<sup>2</sup>, -30 dBm to +20 dBm, 1 to 6000 MHz

Parameter	Freq. Range (MHz)	Min.	Typ.	Max.	Units	
Dynamic Range	1 - 6000	-30	-	+20	dBm	
VSWR	1 - 6000	-	1.1	1.3	:1	
Uncertainty of Power Measurement @ 25°C	@ -30 to +5 dBm	1 - 3000	-	± 0.10	± 0.30	dB
		3000 - 6000	-	± 0.15	± 0.30	dB
	@ +5 to +12 dBm	1 - 3000	-	± 0.15	± 0.30	dB
		3000 - 6000	-	± 0.15	± 0.30	dB
	@ +12 to +20 dBm	1 - 3000	-	± 0.20	± 0.40	dB
		3000 - 6000	-	± 0.20	± 0.40	dB
Uncertainty of Power Measurement @ 0°C to 50°C	@ -30 to +5 dBm	1 - 3000	-	± 0.25	-	dB
		3000 - 6000	-	± 0.25	-	dB
	@ +5 to +12 dBm	1 - 3000	-	± 0.20	-	dB
		3000 - 6000	-	± 0.20	-	dB
	@ +12 to +20 dBm	1 - 3000	-	± 0.35	-	dB
		3000 - 6000	-	± 0.30	-	dB
Linearity @ 25°C	1 - 6000	-	± 3.0	-	%	
Measurement Resolution	1 - 6000	0.01	-	-	dB	
Averaging Range	1 - 6000	1	-	999	-	
Measurement Speed	@ Low Noise Mode	1 - 6000	-	100	-	mSec
	@ Faster Mode		-	30	-	
Current (via host USB)	1 - 6000	-	40	70	mA	

## System Requirements

Parameter	Requirements
Interface	USB HID
Host operating system	32 Bit operating system: Windows 98®, Windows XP®, Windows Vista®, Windows 7® 64 Bit operating system: Windows Vista®, Windows 7® Linux® support: 32/64 Bit operating system
Hardware	Pentium® II or higher, RAM 256 Mb, USB port
USB cable (supplied)	Power sensor to be used with the supplied USB cable only

**Note 2:** All specifications apply to continuous wave (CW) signals.

## Absolute Maximum Ratings

Parameter	Ratings
Operating Temperature	0°C to 50°C
Storage Temperature	-30°C to 70°C
DC Voltage at RF port	15V
CW Power	+27 dBm

Permanent damage may occur if any of these limits are exceeded.

## Typical Performance Curves

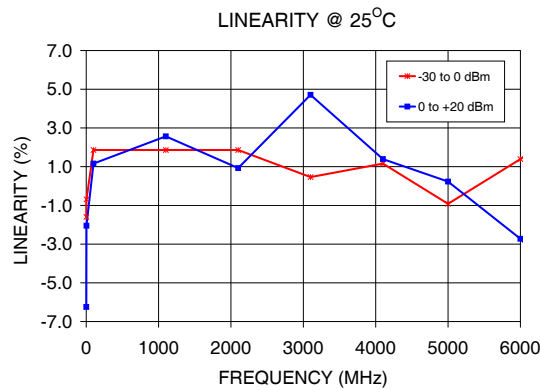
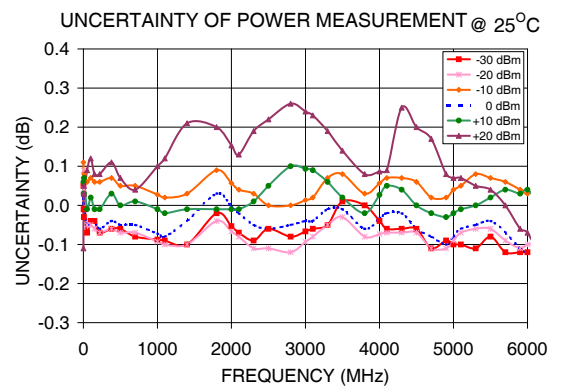
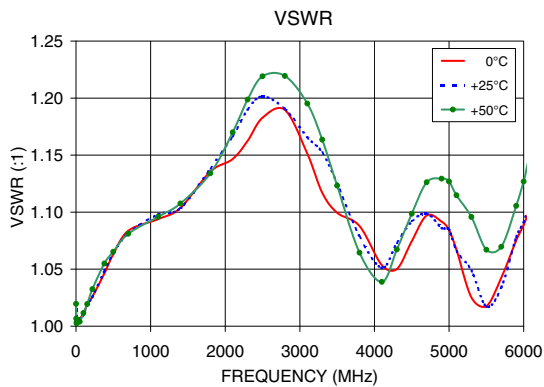

## Outline Drawing (JL1504)

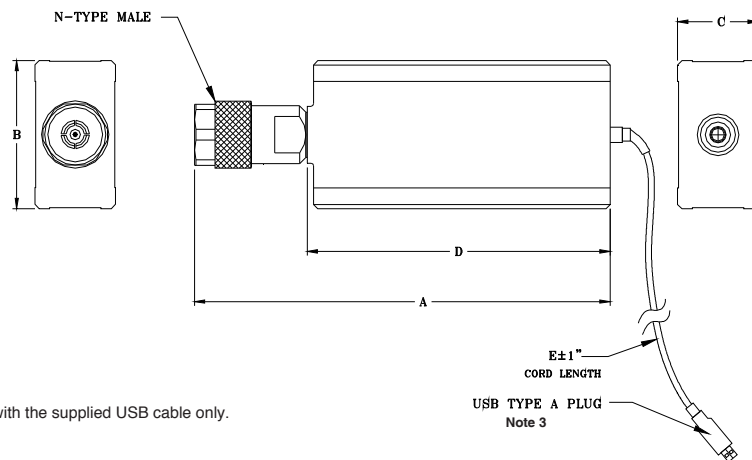

Note 3: Power sensor to be used with the supplied USB cable only.

## Outline Dimensions (inch/mm)

A	B	C	D	E	WT. GRAMS
4.89	1.74	.95	3.50	72.0	250
124.2	44.2	24.1	88.9	1829	



For detailed performance specs & shopping online see web site

P.O. Box 350166, Brooklyn, New York 11235-0003 (718) 934-4500 Fax (718) 332-4661 The Design Engineers Search Engine Provides ACTUAL Data Instantly at [minicircuits.com](http://minicircuits.com)

IF/RF MICROWAVE COMPONENTS

Notes: 1. Performance and quality attributes and conditions not expressly stated in this specification sheet are intended to be excluded and do not form a part of this specification sheet. 2. Electrical specifications and performance data contained herein are based on Mini-Circuit's applicable established test performance criteria and measurement instructions. 3. The parts covered by this specification sheet are subject to Mini-Circuits standard limited warranty and terms and conditions (collectively, "Standard Terms"); Purchasers of this part are entitled to the rights and benefits contained therein. For a full statement of the Standard Terms and the exclusive rights and remedies thereunder, please visit Mini-Circuits' website at [www.minicircuits.com/MCLStore/terms.jsp](http://www.minicircuits.com/MCLStore/terms.jsp).

## Warranty

For a full statement of the limited warranty offered by Mini-Circuits for the PWR-6GHS and the non-exclusive license for the software provided with the PWR-6GHS and the exclusive rights and remedies thereunder, together with Mini-Circuit's limitations of warranties and limitation of liability, please refer to Mini-Circuits User Guide for the PWR-6GHS and Mini-Circuits standard terms of sale found on its standard purchase order acknowledgment form, which are incorporated herein by reference. If you do not have these documents, please contact a Mini-Circuits representative and these documents will be provided promptly. Alternatively, for a copy of Mini-Circuits' standard terms of sale, visit Mini-Circuits' website at [www.minicircuits.com/MCLStore/terms.jsp](http://www.minicircuits.com/MCLStore/terms.jsp).

THE SOFTWARE IS PROVIDED "AS IS", "WITH ALL FAULTS", AND WITHOUT ANY EXPRESS OR IMPLIED WARRANTY OF ANY KIND, ALL OF WHICH ARE HEREBY WAIVED.

## Ordering, Pricing & Availability Information see our web site

Model	Description
PWR-6GHS	USB <i>Smart</i> Power Sensor

Included Accessories	Description
PWR-SEN-6GHS	Power Sensor Head
USB-CBL+ <sup>4</sup>	6 ft data cable with USB Type-A plug connector
NF-SM50+	N-Type Female to SMA Male Adapter.
PWR-SEN-CD	Installation CD

**Note 4:** Power sensor to be used with the supplied USB cable only.

## Calibration

Model	Description
CALSEN-6GHS	Calibration Service



Click Here