

Narrow Band Phase Shifter

50Ω 180° Voltage Variable 8 to 12 MHz

JSPHS-12+ JSPHS-12

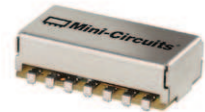

CASE STYLE: BK276
PRICE: \$29.95 ea. QTY (1-9)

+RoHS Compliant
The +Suffix identifies RoHS Compliance. See our web site for RoHS Compliance methodologies and qualifications

Maximum Ratings

Operating Temperature	-40°C to 85°C
Storage Temperature	-55°C to 100°C
RF Input Power	20 dBm max.
Control Voltage	20V

Permanent damage may occur if any of these limits are exceeded.

Pin Connections

IN	1
OUT	7
BIAS	4,6^
GROUND	2,3,5,8,9,10,11,12,13,14

^ proper operation is achieved with pins 4 or 6 or both connected to BIAS.

Outline Drawing

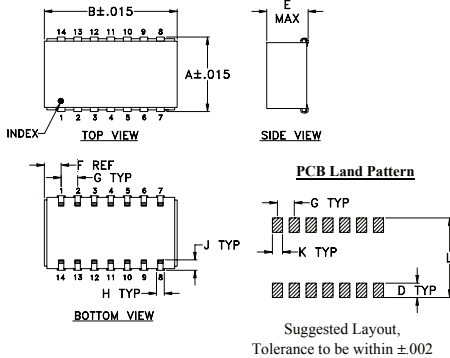

Outline Dimensions (inch/mm)

A	B	C	D	E	F	G
.450	.803	--	.100	.250	.102	.100
11.43	20.40	--	2.54	6.35	2.59	2.54
H	J	K	L	wt		
.047	.065	.065	.470	grams		
1.19	1.65	1.65	11.94	3.0		

Demo Board MCL P/N: TB-122 Suggested PCB Layout (PL-030)

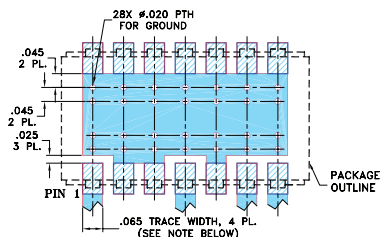

- NOTE: 1. TRACE WIDTH IS SHOWN FOR ROGERS R04350B WITH DIELECTRIC THICKNESS 0.030" ± 0.002"; COPPER: 1/2 OZ. EACH SIDE. FOR OTHER MATERIALS TRACE WIDTH MAY NEED TO BE MODIFIED.
2. BOTTOM SIDE OF THE PCB IS CONTINUOUS GROUND PLANE.
- DENOTES PCB COPPER LAYOUT WITH SMOBC (SOLDER MASK OVER BARE COPPER)
 - DENOTES COPPER LAND PATTERN FREE OF SOLDER MASK

Notes

- A. Performance and quality attributes and conditions not expressly stated in this specification document are intended to be excluded and do not form a part of this specification document.
B. Electrical specifications and performance data contained in this specification document are based on Mini-Circuit's applicable established test performance criteria and measurement instructions.
C. The parts covered by this specification document are subject to Mini-Circuits standard limited warranty and terms and conditions (collectively, "Standard Terms"); Purchasers of this part are entitled to the rights and benefits contained therein. For a full statement of the Standard Terms and the exclusive rights and remedies thereunder, please visit Mini-Circuits' website at www.minicircuits.com/MCLStore/terms.jsp

Features

- low insertion loss, 1.0 dB typ.
- good VSWR, 1.3:1 typ.
- solder-plated J-leads for excellent solderability and strain relief
- aqueous washable

Applications

- IF processing in VHF receiver

Phase Shifter Electrical Specifications

FREQUENCY (MHz)	PHASE RANGE (Degrees)	INSERTION LOSS (dB)		CONTROL VOLTAGE (V)	CONTROL BANDWIDTH (kHz)	VSWR (:1)	
		Typ.	Max.			Typ.	Max.
8-12	180	0.9	2.5	0-15	DC-50	1.2	1.8

Maximum operating power, 0 dBm

DC input resistance at Control port: 4900 ohms typ.

Typical Performance Data

Control Voltage (V)	Phase Shift* (Degrees)			VSWR (:1)			Insertion Loss (dB)		
	8 MHz	10 MHz	12 MHz	8 MHz	10 MHz	12 MHz	8 MHz	10 MHz	12 MHz
0.00	0.01	0.00	-0.02	1.47	1.16	1.17	1.10	0.86	0.99
3.00	62.78	13.87	4.72	1.37	1.22	1.20	1.24	0.93	1.02
5.00	118.62	27.87	8.71	1.21	1.27	1.22	1.09	1.03	1.06
7.00	166.45	50.85	14.20	1.26	1.33	1.26	0.88	1.18	1.09
9.00	198.98	95.55	23.07	1.25	1.34	1.30	0.75	1.40	1.17
11.00	220.91	177.11	41.70	1.20	1.28	1.39	0.68	1.31	1.34
13.00	236.63	245.09	109.31	1.15	1.39	1.47	0.65	0.96	1.94
15.00	247.74	278.45	247.24	1.11	1.31	1.34	0.64	0.81	1.25

* Normalized at control voltage = 0V

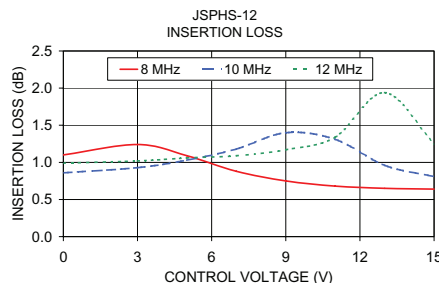
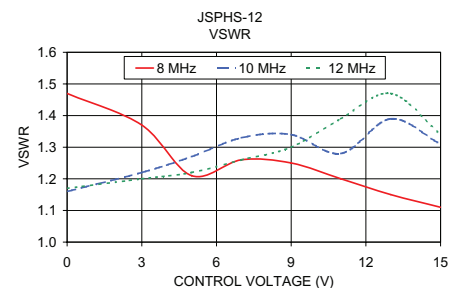
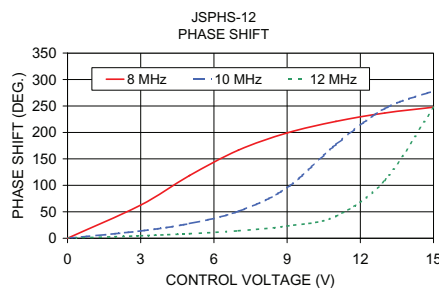

electrical schematic

