

Voltage Controlled Oscillator

ROS-2940C+

Low Noise 2935 to 2940 MHz

Features

- linear tuning characteristics
- low phase noise
- low pulling
- low pushing
- aqueous washable

Applications

- wireless communications
- military & avionics



CASE STYLE: CK1113
PRICE: \$ 25.95 ea. QTY (5-49)

+RoHS Compliant

The +Suffix identifies RoHS Compliance. See our web site for RoHS Compliance methodologies and qualifications

Electrical Specifications

| MODEL NO. | FREQ. (MHz) | | POWER OUTPUT (dBm) | PHASE NOISE dBc/Hz SSB at offset frequencies, kHz | | | | TUNING | | | | | NON HARMONIC SPURIOUS (dBc) | HARMONICS (dBc) | | PULLING pk-pk @ 12 dB (MHz) | PUSHING (MHz/V) | DC OPERATING POWER | |
|------------|-------------|------|--------------------|---|------|------|------|--------|-------------------|-----------------------|---------------|---------------------------------|-----------------------------|-----------------|------|-----------------------------|-----------------|--------------------|------|
| | Min. | Max. | | Typ. | 1 | 10 | 100 | 1000 | VOLTAGE RANGE (V) | SENSI- TIVITY (MHz/V) | PORT CAP (pF) | 3 dB MODULATION BANDWIDTH (MHz) | | Typ. | Typ. | | | Typ. | Max. |
| ROS-2940C+ | 2935 | 2940 | +3.8 | -89 | -116 | -136 | -156 | 0.5 | 5 | 14 | 18 | 75 | -90 | -17 | -10 | 0.3 | 0.7 | 7 | 40 |

Pin Connections

| | |
|--------|--------------------------------|
| RF OUT | 10 |
| VCC | 14 |
| V-TUNE | 2 |
| GROUND | 1,3,4,5,6,7,8,9,11,12,13,15,16 |

Maximum Ratings

| | |
|--------------------------------------|----------------|
| Operating Temperature | -55°C to 85°C |
| Storage Temperature | -55°C to 100°C |
| Absolute Max. Supply Voltage (Vcc) | 9V |
| Absolute Max. Tuning Voltage (Vtune) | 7V |
| All specifications | 50 ohm system |

Permanent damage may occur if any of these limits are exceeded.

Outline Drawing

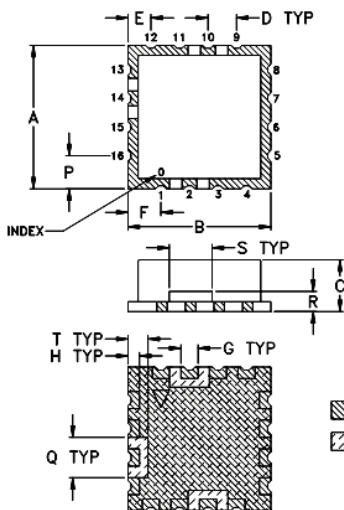

PCB Land Pattern

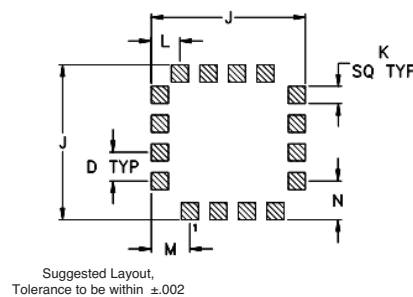

Demo Board MCL P/N: TB-10 Suggested PCB Layout (PL-012)

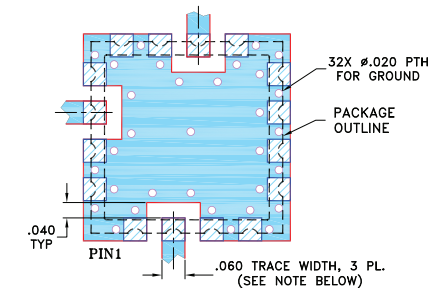

NOTES:

1. TRACE WIDTH IS SHOWN FOR FR4 WITH DIELECTRIC THICKNESS .030" ± .002"; COPPER: 1/2 OZ. EACH SIDE. FOR OTHER MATERIALS TRACE WIDTH MAY NEED TO BE MODIFIED.
 2. BOTTOM SIDE OF THE BOTTOM IS CONTINUOUS GROUND PLANE.
- DENOTES PCB COPPER LAYOUT WITH SMOBC (SOLDER MASK OVER BARE COPPER)
 DENOTES COPPER LAND PATTERN FREE OF SOLDER MASK

Outline Dimensions (inch/mm)

| A | B | C | D | E | F | G | H | J | K | L | M | N | P | Q | R | S | T | wt. |
|-------|-------|------|------|------|------|------|------|-------|------|------|------|------|------|------|------|------|------|-------|
| .500 | .500 | .220 | .100 | .080 | .115 | .060 | .040 | .540 | .060 | .100 | .135 | .135 | .115 | .140 | .070 | .150 | .070 | grams |
| 12.70 | 12.70 | 5.59 | 2.54 | 2.03 | 2.92 | 1.52 | 1.02 | 13.72 | 1.52 | 2.54 | 3.43 | 3.43 | 2.92 | 3.56 | 1.78 | 3.81 | 1.78 | 1.2 |



For detailed performance specs & shopping online see web site

P.O. Box 350166, Brooklyn, New York 11235-0003 (718) 934-4500 Fax (718) 332-4661 The Design Engineers Search Engine Provides ACTUAL Data Instantly at minicircuits.com

Notes: 1. Performance and quality attributes and conditions not expressly stated in this specification sheet are intended to be excluded and do not form a part of this specification sheet. 2. Electrical specifications and performance data contained herein are based on Mini-Circuits' applicable established test performance criteria and measurement instructions. 3. The parts covered by this specification sheet are subject to Mini-Circuits standard limited warranty and terms and conditions (collectively, "Standard Terms"); Purchasers of this part are entitled to the rights and benefits contained therein. For a full statement of the Standard Terms and the exclusive rights and remedies thereunder, please visit Mini-Circuits' website at www.minicircuits.com/MCLStore/terms.jsp.

REV. B
M139652
EDR-9363F1
ROS-2940C+
RAV
121205
Page 1 of 2

Performance Data & Curves*

ROS-2940C+

| V TUNE | TUNE SENS (MHz/V) | FREQUENCY (MHz) | | | POWER OUTPUT (dBm) | | | Icc (mA) | HARMONICS (dBc) | | | FREQ. PUSH (MHz/V) | FREQ. PULL (MHz) | PHASE NOISE (dBc/Hz) at offsets | | | | FREQ OFFSET (KHz) | PHASE NOISE at 2938 MHz (dBc/Hz) |
|--------|-------------------|-----------------|--------|--------|--------------------|-------|-------|----------|-----------------|-------|-------|--------------------|------------------|---------------------------------|--------|--------|--------|-------------------|----------------------------------|
| | | -55°C | +25°C | +85°C | -55°C | +25°C | +85°C | | F2 | F3 | F4 | | | 1kHz | 10kHz | 100kHz | 1MHz | | |
| 0.00 | 15.89 | 2919.3 | 2915.8 | 2913.3 | 4.25 | 3.79 | 3.31 | 34.94 | -17.4 | -32.0 | -37.1 | 0.55 | 0.67 | -88.7 | -116.1 | -137.3 | -155.5 | 1.0 | -88.95 |
| 0.50 | 14.41 | 2926.8 | 2923.5 | 2921.2 | 4.25 | 3.77 | 3.31 | 35.00 | -17.4 | -30.9 | -38.0 | 0.60 | 0.54 | -89.0 | -116.0 | -136.8 | -156.0 | 2.0 | -98.17 |
| 0.75 | 14.16 | 2930.3 | 2927.1 | 2924.8 | 4.27 | 3.77 | 3.30 | 35.03 | -17.5 | -30.8 | -38.1 | 0.62 | 0.46 | -88.9 | -116.0 | -137.4 | -155.6 | 3.5 | -105.30 |
| 1.00 | 14.07 | 2933.8 | 2930.7 | 2928.4 | 4.28 | 3.78 | 3.30 | 35.05 | -17.5 | -30.7 | -37.2 | 0.63 | 0.37 | -88.8 | -115.9 | -137.2 | -155.4 | 6.0 | -110.99 |
| 1.25 | 14.10 | 2937.3 | 2934.2 | 2931.9 | 4.29 | 3.79 | 3.31 | 35.08 | -17.4 | -30.4 | -36.2 | 0.63 | 0.27 | -88.5 | -115.9 | -136.9 | -155.1 | 8.5 | -114.44 |
| 1.50 | 14.23 | 2940.8 | 2937.7 | 2935.4 | 4.30 | 3.80 | 3.32 | 35.10 | -17.4 | -30.0 | -35.7 | 0.64 | 0.17 | -88.5 | -116.0 | -137.3 | -156.1 | 10.0 | -115.89 |
| 1.75 | 14.45 | 2944.3 | 2941.3 | 2938.9 | 4.30 | 3.81 | 3.33 | 35.11 | -17.4 | -29.6 | -36.5 | 0.64 | 0.14 | -88.2 | -115.8 | -137.0 | -155.3 | 20.8 | -123.35 |
| 2.00 | 14.75 | 2947.9 | 2944.9 | 2942.6 | 4.29 | 3.81 | 3.35 | 35.13 | -17.4 | -29.3 | -37.7 | 0.65 | 0.19 | -88.1 | -115.8 | -137.4 | -156.3 | 35.6 | -128.29 |
| 2.25 | 15.09 | 2951.6 | 2948.6 | 2946.2 | 4.27 | 3.80 | 3.36 | 35.13 | -17.5 | -29.3 | -37.3 | 0.65 | 0.29 | -87.7 | -115.7 | -137.8 | -156.2 | 60.8 | -132.58 |
| 2.50 | 15.45 | 2955.3 | 2952.4 | 2950.0 | 4.25 | 3.79 | 3.36 | 35.14 | -17.6 | -29.3 | -36.7 | 0.64 | 0.39 | -87.6 | -115.6 | -137.0 | -156.3 | 86.9 | -136.14 |
| 2.75 | 15.85 | 2959.2 | 2956.2 | 2953.8 | 4.22 | 3.78 | 3.36 | 35.13 | -17.8 | -29.2 | -36.6 | 0.63 | 0.48 | -87.8 | -115.6 | -137.1 | -155.8 | 100.0 | -137.24 |
| 3.00 | 16.28 | 2963.2 | 2960.2 | 2957.8 | 4.19 | 3.75 | 3.35 | 35.12 | -18.1 | -28.7 | -36.0 | 0.63 | 0.56 | -87.3 | -115.5 | -136.8 | -155.9 | 148.4 | -139.83 |
| 3.25 | 16.70 | 2967.2 | 2964.3 | 2961.8 | 4.15 | 3.73 | 3.34 | 35.11 | -18.4 | -28.1 | -35.4 | 0.61 | 0.63 | -87.3 | -115.4 | -137.2 | -156.1 | 177.4 | -140.76 |
| 3.50 | 17.10 | 2971.4 | 2968.4 | 2965.9 | 4.09 | 3.70 | 3.33 | 35.08 | -18.6 | -27.5 | -36.0 | 0.60 | 0.67 | -86.9 | -115.3 | -137.1 | -156.3 | 212.1 | -141.53 |
| 3.75 | 17.46 | 2975.7 | 2972.7 | 2970.2 | 4.05 | 3.67 | 3.32 | 35.06 | -18.8 | -27.1 | -37.8 | 0.57 | 0.70 | -86.6 | -115.2 | -137.1 | -155.7 | 303.1 | -143.76 |
| 4.00 | 17.75 | 2980.1 | 2977.1 | 2974.5 | 3.97 | 3.63 | 3.30 | 35.04 | -18.9 | -27.6 | -36.9 | 0.54 | 0.70 | -86.2 | -115.0 | -136.6 | -156.1 | 355.9 | -145.20 |
| 4.25 | 17.95 | 2984.5 | 2981.5 | 2978.9 | 3.89 | 3.57 | 3.27 | 35.01 | -18.8 | -27.4 | -36.2 | 0.50 | 0.69 | -86.5 | -115.0 | -136.9 | -155.9 | 499.7 | -148.22 |
| 4.50 | 18.02 | 2989.1 | 2986.0 | 2983.4 | 3.80 | 3.51 | 3.23 | 34.98 | -18.8 | -27.4 | -35.3 | 0.46 | 0.65 | -86.1 | -114.8 | -136.8 | -155.6 | 597.4 | -150.52 |
| 4.75 | 17.90 | 2993.6 | 2990.5 | 2987.8 | 3.71 | 3.45 | 3.19 | 34.95 | -18.7 | -27.0 | -36.1 | 0.39 | 0.59 | -86.1 | -114.5 | -136.3 | -154.9 | 984.8 | -155.84 |
| 5.00 | 17.53 | 2998.1 | 2995.0 | 2992.3 | 3.62 | 3.39 | 3.15 | 34.91 | -18.8 | -27.1 | -35.5 | 0.31 | 0.49 | -86.1 | -114.2 | -136.5 | -155.6 | 1000.0 | -155.99 |

*at 25°C unless mentioned otherwise

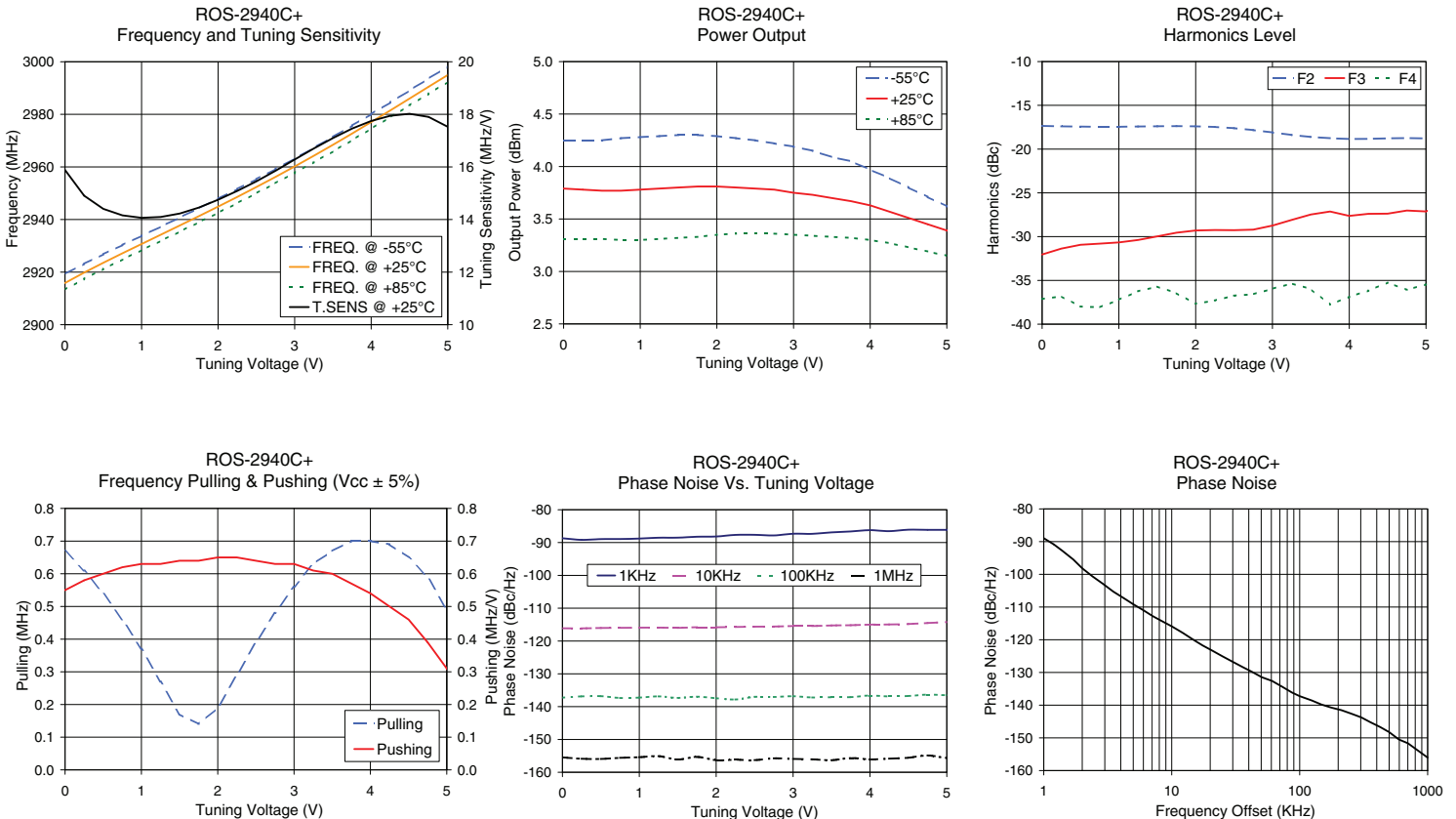

For detailed performance specs & shopping online see web site

P.O. Box 350166, Brooklyn, New York 11235-0003 (718) 934-4500 Fax (718) 332-4661 The Design Engineers Search Engine Provides ACTUAL Data Instantly at minicircuits.com

Notes: 1. Performance and quality attributes and conditions not expressly stated in this specification sheet are intended to be excluded and do not form a part of this specification sheet. 2. Electrical specifications and performance data contained herein are based on Mini-Circuit's applicable established test performance criteria and measurement instructions. 3. The parts covered by this specification sheet are subject to Mini-Circuits standard limited warranty and terms and conditions (collectively, "Standard Terms"); Purchasers of this part are entitled to the rights and benefits contained therein. For a full statement of the Standard Terms and the exclusive rights and remedies thereunder, please visit Mini-Circuits' website at www.minicircuits.com/MCLStore/terms.jsp.