

# Coaxial Frequency Mixer

Level 23 (LO Power +23 dBm) 0.1 to 500 MHz

## ZFY-1+



### Maximum Ratings

Operating Temperature	-55°C to 100°C
Storage Temperature	-55°C to 100°C
RF Power	350mW
IF Current	40mA

Permanent damage may occur if any of these limits are exceeded.

### Coaxial Connections

LO	1
RF	2
IF	3

### Features

- low conversion loss, 4.85 dB typ.
- good L-R & L-I isolation, 46 dB typ.
- rugged shielded case

### Applications

- VHF/UHF
- instrumentation
- federal & defense communications

BNC version shown  
CASE STYLE: K18

Connectors	Model	Price	Qty.
BNC	ZFY-1+	\$74.95	(1-9)
SMA	ZFY-1-S+	\$79.95	(1-9)
BRACKET (OPTION "B")		\$5.00	(1+)

+ RoHS compliant in accordance with EU Directive (2002/95/EC)

The +Suffix has been added in order to identify RoHS Compliance. See our web site for RoHS Compliance methodologies and qualifications.

### Outline Drawing

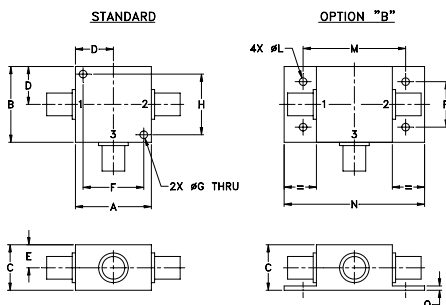

### Outline Dimensions (inch/mm)

A	B	C	D	E	F	G	H
1.25	1.25	.75	.63	.38	1.00	.125	1.000
31.75	31.75	19.05	16.00	9.65	25.40	3.18	25.40

J	K	L	M	N	P	Q	wt
--	--	.125	1.688	2.18	.75	.07	grams
--	--	3.18	42.88	55.37	19.05	1.78	70.0

### Electrical Specifications

FREQUENCY (MHz)		CONVERSION LOSS (dB)				LO-RF ISOLATION (dB)						LO-IF ISOLATION (dB)					
LO/RF $f_L-f_U$	IF	Mid-Band m		Total Range Max.	Max.	L		M		U		L		M		U	
		$\bar{X}$	$\sigma$			Typ.	Min.	Typ.	Min.	Typ.	Min.	Typ.	Min.	Typ.	Min.	Typ.	Min.
0.1-500	0.01-500*	4.85	0.18	6.0	7.5	40	20	46	35	40	30	37	23	46	35	40	30

1 dB COMP.: +20 dBm typ.

\*IF response from 0.1 to 0.01 MHz falls off 3 dB.

L = low range [ $f_L$  to  $10 f_L$ ] M = mid range [ $10 f_L$  to  $f_U/10$ ] U = upper range [ $f_U/2$  to  $f_U$ ]

m = mid band [ $2 f_L$  to  $f_U/2$ ]

### Typical Performance Data

Frequency (MHz)		Conversion Loss (dB)	Isolation L-R (dB)	Isolation L-I (dB)	VSWR RF Port (:1)	VSWR LO Port (:1)
RF	LO	LO +23dBm	LO +23dBm	LO +23dBm	LO +23dBm	LO +23dBm
0.10	30.10	5.89	25.02	25.81	1.35	1.41
1.00	31.00	5.82	46.68	47.33	1.37	1.45
10.00	40.00	5.59	47.08	47.94	1.37	1.35
20.00	50.00	5.60	46.71	47.64	1.37	1.42
34.58	64.58	5.59	45.97	46.92	1.37	1.46
69.05	99.05	5.57	45.02	46.05	1.38	1.42
100.00	70.00	5.52	43.63	44.10	1.42	1.37
120.77	90.77	5.53	42.68	43.10	1.45	1.34
155.24	125.24	5.68	40.68	41.09	1.50	1.37
189.72	159.72	5.73	39.25	39.09	1.57	1.32
224.19	194.19	5.85	39.09	38.89	1.53	1.30
241.43	211.43	5.95	38.42	38.05	1.64	1.31
258.67	228.67	6.00	37.01	36.93	1.68	1.25
293.15	263.15	5.91	36.97	35.23	1.76	1.25
327.62	297.62	5.81	37.56	34.01	1.81	1.30
362.10	332.10	5.87	40.25	33.42	1.89	1.34
396.57	366.57	5.96	41.18	33.85	1.95	1.37
431.05	401.05	6.22	41.74	36.25	1.99	1.42
465.53	435.53	6.39	43.60	37.76	2.05	1.53
500.00	470.00	6.56	42.79	37.30	2.02	1.55

### Electrical Schematic

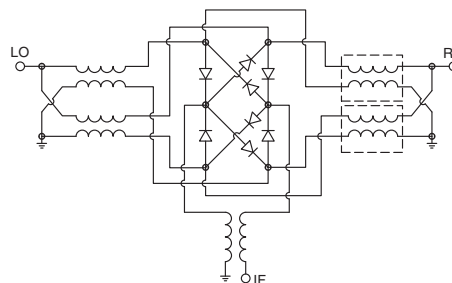

**Mini-Circuits**  
ISO 9001 ISO 14001 AS 9100 CERTIFIED

P.O. Box 350166, Brooklyn, New York 11235-0003 (718) 934-4500 Fax (718) 332-4661 The Design Engineers Search Engine [www.minicircuits.com](http://www.minicircuits.com) Provides ACTUAL Data Instantly at [minicircuits.com](http://minicircuits.com)

IF/RF MICROWAVE COMPONENTS

For detailed performance specs & shopping online see web site

Notes: 1. Performance and quality attributes and conditions not expressly stated in this specification sheet are intended to be excluded and do not form a part of this specification sheet. 2. Electrical specifications and performance data contained herein are based on Mini-Circuit's applicable established test performance criteria and measurement instructions. 3. The parts covered by this specification sheet are subject to Mini-Circuit's standard limited warranty and terms and conditions (collectively, "Standard Terms"); Purchasers of this part are entitled to the rights and benefits contained therein. For a full statement of the Standard Terms and the exclusive rights and remedies thereunder, please visit Mini-Circuit's website at [www.minicircuits.com/MCLStore/terms.jsp](http://www.minicircuits.com/MCLStore/terms.jsp).

REV. C  
M128455  
ZFY-1+  
DJ/TD/CP/AM  
110216  
Page 1 of 2

