

Coaxial Frequency Mixer

Level 7 (LO Power +7 dBm) 5 to 1250 MHz

ZFM-4+
ZFM-4



Maximum Ratings

Operating Temperature	-55°C to 100°C
Storage Temperature	-55°C to 100°C
RF Power	50mW
IF Current	40mA

Permanent damage may occur if any of these limits are exceeded.

Coaxial Connections

LO	1
RF	2
IF	3

Features

- low conversion loss, 5.70 dB typ.
- high L-R isolation, 40 dB typ, L-I, 35 dB typ.
- phase detection, positive polarity
- rugged shielded case

Applications

- VHF/UHF
- cellular
- instrumentation
- federal & defense communications

SMA version shown

CASE STYLE: K18

Connectors	Model	Price	Qty.
BNC	ZFM-4(+)	\$61.95 ea.	(1-9)
SMA	ZFM-4-S+	\$66.95 ea.	(1-9)
BRACKET (OPTION "B")		\$5.00	(1+)

+ RoHS compliant in accordance with EU Directive (2002/95/EC)

The +Suffix has been added in order to identify RoHS Compliance. See our web site for RoHS Compliance methodologies and qualifications.

Outline Drawing

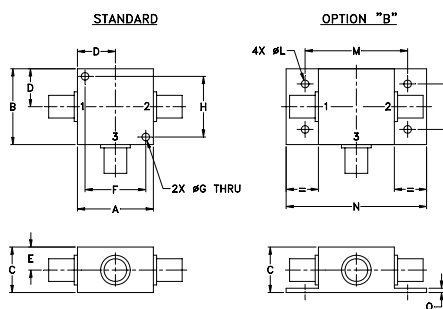

Outline Dimensions (inch/mm)

A	B	C	D	E	F	G	H
1.25	1.25	.75	.63	.38	1.00	.125	1.000
31.75	31.75	19.05	16.00	9.65	25.40	3.18	25.40

J	K	L	M	N	P	Q	wt
--	--	.125	1.688	2.18	.75	.07	grams
--	--	3.18	42.88	55.37	19.05	1.78	70.0

Electrical Specifications

FREQUENCY (MHz)		CONVERSION LOSS (dB)				LO-RF ISOLATION (dB)						LO-IF ISOLATION (dB)							
LO/RF	IF	Mid-Band m		Total Range	L			M			U			L		M		U	
f_L - f_U		\bar{X}	σ	Max.	Typ.	Min.	Typ.	Min.	Typ.	Min.	Typ.	Min.	Typ.	Min.	Typ.	Min.	Typ.	Min.	
5-1250	DC-1250	5.70	0.34	7.5	8.5	50	45	40	30	30	25	45	40	35	25	25	20	20	

1 dB COMP.: +1 dBm typ.

For phase detection: DC output has positive with in-phase LO and RF signals

L = low range [f_L to $10 f_L$]

m = mid band [$2f_L$ to $f_U/2$]

M = mid range [$10 f_U$ to $f_U/2$]

U = upper range [$f_U/2$ to f_U]

Typical Performance Data

Frequency (MHz)		Conversion Loss (dB)	Isolation L-R (dB)	Isolation L-I (dB)	VSWR RF Port (:1)	VSWR LO Port (:1)
RF	LO	LO +7dBm	LO +7dBm	LO +7dBm	LO +7dBm	LO +7dBm
5.00	35.00	7.08	67.00	62.10	1.54	3.00
20.00	50.00	6.84	67.00	59.11	1.42	2.83
50.00	80.00	6.64	50.64	49.95	1.34	2.85
100.00	70.00	6.48	44.54	43.90	1.31	2.72
138.39	108.39	6.51	38.97	38.26	1.26	2.49
227.32	197.32	6.59	37.28	36.56	1.25	2.44
271.78	241.78	6.44	34.49	34.10	1.20	2.33
360.71	330.71	6.47	32.40	32.75	1.17	2.23
449.64	419.64	6.57	31.70	31.16	1.13	2.19
538.57	508.57	6.45	31.48	30.87	1.12	2.17
583.03	553.03	6.54	30.37	30.53	1.12	2.14
671.96	641.96	6.82	29.62	29.00	1.13	2.05
760.89	730.89	6.83	29.45	27.36	1.16	2.02
849.82	819.82	6.86	29.60	26.76	1.18	2.05
894.28	864.28	7.01	30.37	25.36	1.22	2.12
983.21	953.21	7.24	29.78	23.67	1.24	2.11
1027.70	997.70	7.43	29.36	22.34	1.31	2.17
1116.60	1086.60	7.58	28.75	21.27	1.43	2.24
1200.00	1170.00	7.70	28.39	20.82	1.52	2.32
1250.00	1220.00	7.80	28.05	20.19	1.62	2.36

Electrical Schematic

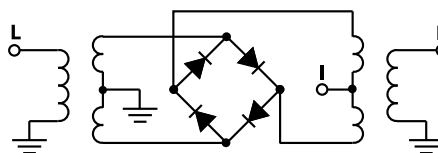

Mini-Circuits
ISO 9001 ISO 14001 AS 9100 CERTIFIED

For detailed performance specs & shopping online see web site

P.O. Box 350166, Brooklyn, New York 11235-0003 (718) 934-4500 Fax (718) 332-4661 The Design Engineers Search Engine www.minicircuits.com Provides ACTUAL Data Instantly at [minicircuits.com](http://www.minicircuits.com)

IF/RF MICROWAVE COMPONENTS

Notes: 1. Performance and quality attributes and conditions not expressly stated in this specification sheet are intended to be excluded and do not form a part of this specification sheet. 2. Electrical specifications and performance data contained herein are based on Mini-Circuit's applicable established test performance criteria and measurement instructions. 3. The parts covered by this specification sheet are subject to Mini-Circuit's standard limited warranty and terms and conditions (collectively, "Standard Terms"); Purchasers of this part are entitled to the rights and benefits contained therein. For a full statement of the Standard Terms and the exclusive rights and remedies thereunder, please visit Mini-Circuit's website at www.minicircuits.com/MCLStore/terms.jsp.

REV. B
M108294
ZFM-4
DJ/TD/CP/AM
120306
Page 1 of 2

