

# Ceramic Low Pass Filter

50Ω DC to 1800 MHz

## LFCN-1800D+



CASE STYLE: FV1206  
PRICE: \$3.49 ea. QTY (20)

**+RoHS Compliant**  
The +Suffix identifies RoHS Compliance. See our web site for RoHS Compliance methodologies and qualifications



Available Tape and Reel at no extra cost

Reel Size	Devices/Reel
7"	20, 50, 100, 200, 500, 1000, 3000

### Maximum Ratings

Operating Temperature	-55°C to 100°C
Storage Temperature	-55°C to 100°C
RF Power Input*	10W max. at 25°C
Max. DC Voltage at pins 1&3	25 VDC
DC Current Input to Output	0.5A max. at 25°C

\* Derate linearly to 3.5W at 100°C ambient.  
Permanent damage may occur if any of these limits are exceeded.

### Pin Connections

RF IN	1
RF OUT	3
GROUND	2,4

### Outline Drawing

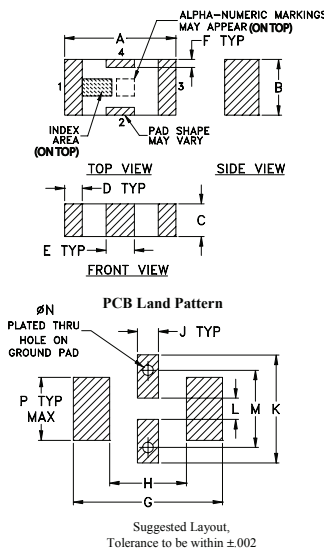

### Outline Dimensions (inch/mm)

A	B	C	D	E	F	G
.126	.063	.037	.020	.032	.009	.169
3.20	1.60	0.94	0.51	0.81	0.23	4.29

H	J	K	L	M	N	P	wt
.087	.024	.122	.024	.087	.012	.071	grams
2.21	0.61	3.10	0.61	2.21	0.30	1.80	.020

### Demo Board MCL P/N: TB-270 Suggested PCB Layout (PL-137)

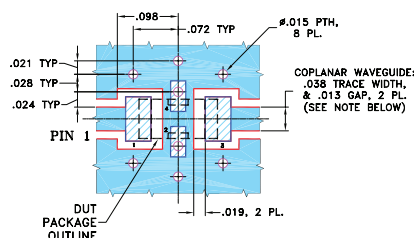

- NOTES:**
1. COPLANAR WAVEGUIDE PARAMETERS ARE SHOWN FOR ROGERS RO4350B WITH THICKNESS .020" ± .0015". COPPER: 1/2 OZ. EACH SIDE. FOR OTHER MATERIALS TRACE WIDTH & GAP MAY NEED TO BE MODIFIED.
  2. BOTTOM SIDE OF THE PCB IS CONTINUOUS GROUND PLANE.
    - DENOTES PCB COPPER LAYOUT WITH SMOBC (SOLDER MASK OVER BARE COPPER)
    - DENOTES COPPER LAND PATTERN FREE OF SOLDER MASK

#### Notes

- A. Performance and quality attributes and conditions not expressly stated in this specification document are intended to be excluded and do not form a part of this specification document.  
B. Electrical specifications and performance data contained in this specification document are based on Mini-Circuit's applicable established test performance criteria and measurement instructions.  
C. The parts covered by this specification document are subject to Mini-Circuits standard limited warranty and terms and conditions (collectively, "Standard Terms"); Purchasers of this part are entitled to the rights and benefits contained therein. For a full statement of the Standard Terms and the exclusive rights and remedies thereunder, please visit Mini-Circuits' website at [www.minicircuits.com/MCListore/terms.jsp](http://www.minicircuits.com/MCListore/terms.jsp)

### Features

- excellent power handling, 10W
- small size
- 7 sections
- temperature stable
- LTCC construction
- protected by U.S. Patent 6,943,646

### Applications

- harmonic rejection
- VHF/UHF transmitters/receivers
- lab use

### Electrical Specifications<sup>1,2</sup> at 25°C

Parameter	F#	Frequency (MHz)	Min.	Typ.	Max.	Unit	
Pass Band	Insertion Loss	DC-F1	DC-1800	—	—	1.0	dB
	Freq. Cut-Off	F2	2125	—	3.0	—	dB
	VSWR	DC-F1	DC-1800	—	1.2	—	:1
Stop Band	Rejection Loss	F3	2550	20	—	—	dB
		F4-F5	3000-7200	—	40	—	dB
		F6	8600	—	20	—	dB
	VSWR	F3-F6	2550-8650	—	20	—	:1

1. DC Resistance to ground is 100 Mohms min.
2. Measured on Mini-Circuits Characterization Test Board TB-270.

### Typical Frequency Response

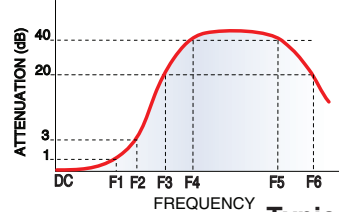

### Electrical Schematic

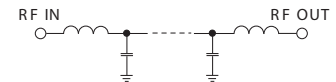

### Typical Performance Data at 25°C

Frequency (MHz)	Insertion Loss (dB)	VSWR (:1)
1.00	0.03	1.01
1000.00	0.41	1.27
1800.00	0.74	1.06
1900.00	0.86	1.06
2000.00	1.06	1.08
2100.00	1.46	1.22
2200.00	2.72	1.88
2300.00	6.84	4.29
2400.00	15.18	9.33
2500.00	28.34	14.03
3000.00	47.02	21.46
4000.00	36.22	28.03
5000.00	41.86	44.55
8000.00	25.75	15.81
9000.00	21.86	14.03

