

Fixed Amplitude Mismatch, Wideband Electronic Line Stretcher

ELS-1300

50Ω 360° Voltage Variable 750 to 1300 MHz



Maximum Ratings

Operating Temperature	0°C to 50 °C
Storage Temperature	-40°C to 100°C
RF Input Power	13dBm
Control Voltage	0.5V to 30V

Permanent damage may occur if any of these limits are exceeded.

Coaxial Connections

RF IN	1
MONITOR OUT*	2
CONTROL	3

* Monitor out port should be connected to a 50-ohm load

Outline Drawing

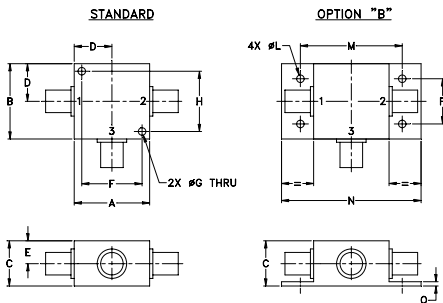

Outline Dimensions (inch/mm)

A	B	C	D	E	F	G	H
1.25	1.25	.75	.63	.38	1.00	.125	1.000
31.75	31.75	19.05	16.00	9.65	25.40	3.18	25.40

J	K	L	M	N	P	Q	wt
--	--	.125	1.688	2.18	.75	.07	grams
--	--	3.18	42.88	55.37	19.05	1.78	70.0

Features

- over 360° phase shift of the reflected signal
- normalized and stable magnitude of the reflected signal
- voltage controlled for automated applications
- protected under US Patent 6,479,977

Applications

- automated load-pull measurement of oscillators¹

Electrical Specifications

FREQUENCY RANGE (MHz)	INPUT POWER (dBm)	PHASE RANGE (Degrees)	RETURN LOSS (dB)	CONTROL VOLTAGE (V)
f_L - f_U	Max.	Min.	Typ.	
750-1300	10	360	10-12	1-25

1. See Application Note AN-45-002 on our web site.

Typical Performance Data

FREQ. (MHz)	PHASE SHIFT (Deg.)		RETURN LOSS (dBr)					
	0°C	50°C	Vc=0.5V @ 0°C	Vc=10V @ 0°C	Vc=25V @ 0°C	Vc=0.5V @ +50°C	Vc=10V @ +50°C	Vc=25V @ +50°C
600	310.91	302.56	-11.32	-10.01	-9.88	-11.15	-9.91	-9.88
700	368.80	357.25	-11.63	-10.42	-9.79	-11.33	-10.27	-9.77
740	402.57	390.39	-11.81	-10.68	-9.83	-11.50	-10.51	-9.80
820	450.97	440.76	-11.61	-11.23	-9.98	-11.17	-11.02	-9.93
900	472.51	464.41	-11.28	-11.46	-10.27	-11.14	-11.26	-10.19
980	477.28	470.45	-11.09	-11.22	-10.74	-10.96	-11.10	-10.59
1060	466.16	460.26	-11.22	-11.19	-11.33	-11.05	-11.05	-11.10
1140	430.97	424.98	-11.87	-11.38	-11.78	-11.54	-11.17	-11.60
1220	396.57	386.46	-12.73	-11.50	-11.49	-12.25	-11.28	-11.37
1260	390.00	379.35	-12.77	-11.46	-11.45	-12.35	-11.26	-11.29
1340	381.80	373.28	-12.13	-11.21	-11.51	-11.90	-11.06	-11.29
1420	367.17	361.69	-11.45	-10.99	-11.46	-11.29	-10.91	-11.23
1500	345.54	342.13	-10.95	-10.96	-11.25	-10.84	-10.91	-11.08

Maximum Phase Shift vs. Frequency at temperature extremes @ Pin = +7 dBm

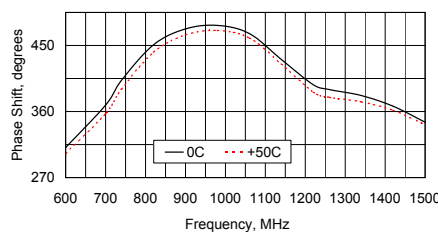

Return Loss vs. Frequency at temperature extremes @ Pin = +7 dBm

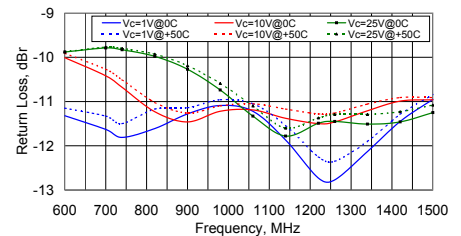

Application Block Diagram

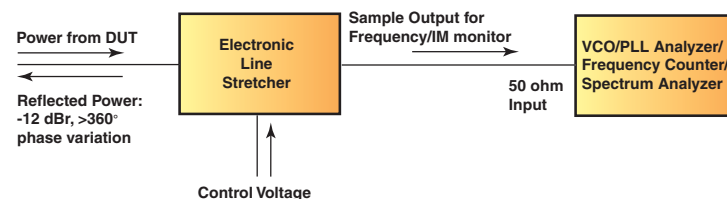

Notes

- Performance and quality attributes and conditions not expressly stated in this specification document are intended to be excluded and do not form a part of this specification document.
- Electrical specifications and performance data contained in this specification document are based on Mini-Circuits' applicable established test performance criteria and measurement instructions.
- The parts covered by this specification document are subject to Mini-Circuits standard limited warranty and terms and conditions (collectively, "Standard Terms"); Purchasers of this part are entitled to the rights and benefits contained therein. For a full statement of the Standard Terms and the exclusive rights and remedies thereunder, please visit Mini-Circuits' website at www.minicircuits.com/MCLStore/terms.jsp

