

Fixed Amplitude Mismatch, Wideband Electronic Line Stretcher

ELS-210

50Ω 360° Voltage Variable 80 to 210 MHz



Maximum Ratings

Operating Temperature	0°C to 50 °C
Storage Temperature	-40°C to 100°C
RF Input Power	13dBm
Control Voltage	0.5V to 30V

Permanent damage may occur if any of these limits are exceeded.

Coaxial Connections

RF IN	1
MONITOR OUT*	2
CONTROL	3

* Monitor out port should be connected to a 50-ohm load

Features

- over 360° phase shift of the reflected signal
- normalized and stable magnitude of the reflected signal
- voltage controlled for automated applications
- protected under US Patent 6,479,977

Applications

- automated load-pull measurement of oscillators¹

Electrical Specifications

FREQUENCY RANGE (MHz)	INPUT POWER (dBm)	PHASE RANGE (Degrees)	RETURN LOSS (dB)	CONTROL VOLTAGE (V)
$f_c - f_u$	Max.	Min.	Typ.	
80-210	10	360	10-12	0.5-25

1. See Application Note AN-45-002 on our web site.

Typical Performance Data

FREQ. (MHz)	PHASE SHIFT (Deg.)		RETURN LOSS (dBr)					
	0°C	50°C						
			Vc=0.5V @ 0°C	Vc=10V @ 0°C	Vc=25V @ 0°C	Vc=0.5V @ +50°C	Vc=10V @ +50°C	Vc=25V @ +50°C
50	214.95	222.34	-11.01	-9.86	-9.70	-11.24	-9.92	-9.70
65	359.99	370.33	-10.66	-10.08	-9.82	-10.81	-10.08	-9.91
80	417.15	424.27	-10.76	-10.21	-10.04	-10.92	-10.21	-10.04
95	502.31	519.32	-11.63	-10.23	-10.13	-12.02	-10.31	-10.13
105	558.68	570.75	-10.74	-10.16	-10.16	-10.83	-10.33	-10.16
120	586.13	591.76	-10.13	-10.25	-10.07	-10.13	-10.39	-10.13
135	591.70	594.71	-10.06	-10.70	-10.04	-10.06	-10.83	-10.06
150	590.40	592.21	-10.04	-10.91	-9.97	-10.04	-11.05	-10.04
165	583.66	584.60	-9.98	-10.62	-10.09	-9.98	-10.77	-10.09
180	568.25	567.91	-9.97	-10.52	-10.12	-9.97	-10.64	-10.20
195	533.10	530.82	-10.00	-10.38	-10.38	-10.00	-10.50	-10.50
205	486.07	482.31	-9.98	-10.32	-10.83	-10.03	-10.36	-11.01
220	390.51	387.32	-10.01	-10.18	-11.14	-10.07	-10.25	-11.31
235	333.92	332.49	-10.03	-10.22	-10.57	-10.08	-10.34	-10.63
250	306.43	306.09	-10.06	-10.32	-10.22	-10.06	-10.43	-10.22

Outline Drawing

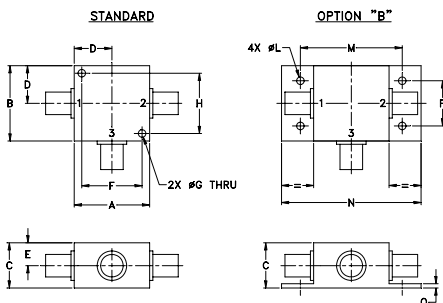

Outline Dimensions (inch/mm)

A	B	C	D	E	F	G	H
1.25	1.25	.75	.63	.38	1.00	.125	1.000
31.75	31.75	19.05	16.00	9.65	25.40	3.18	25.40

J	K	L	M	N	P	Q	wt
--	--	.125	1.688	2.18	.75	.07	grams
--	--	3.18	42.88	55.37	19.05	1.78	70.0

Maximum Phase Shift vs. Frequency at temperature extremes @ Pin = +7 dBm

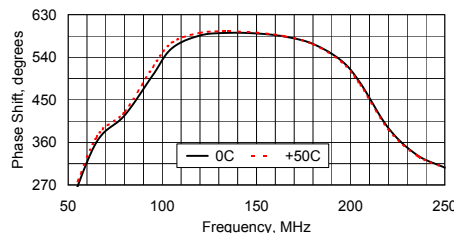

Return Loss vs. Frequency at temperature extremes @ Pin = +7 dBm

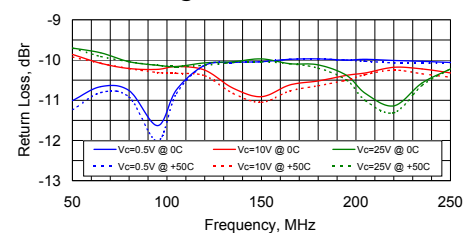

Application Block Diagram

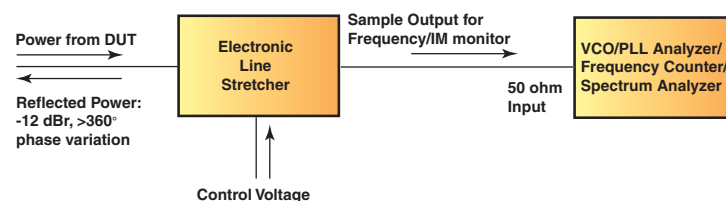

Notes

- Performance and quality attributes and conditions not expressly stated in this specification document are intended to be excluded and do not form a part of this specification document.
- Electrical specifications and performance data contained in this specification document are based on Mini-Circuits' applicable established test performance criteria and measurement instructions.
- The parts covered by this specification document are subject to Mini-Circuits standard limited warranty and terms and conditions (collectively, "Standard Terms"); Purchasers of this part are entitled to the rights and benefits contained therein. For a full statement of the Standard Terms and the exclusive rights and remedies thereunder, please visit Mini-Circuits' website at www.minicircuits.com/MCLStore/terms.jsp

