

Coaxial Directional Coupler

50Ω

10 to 1800 MHz

ZFDC-10-182+



BNC version shown
CASE STYLE: K18

Maximum Ratings

Operating Temperature	-55°C to 100°C
Storage Temperature	-55°C to 100°C

Coaxial Connections

INPUT	1
OUTPUT	2
COUPLED	3

Outline Drawing

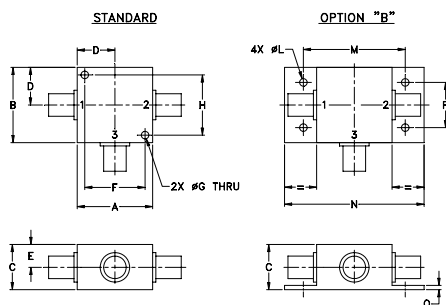

Outline Dimensions (inch/mm)

A	B	C	D	E	F	G	H
1.25	1.25	.75	.63	.38	1.00	.125	1.000
31.75	31.75	19.05	16.00	9.65	25.40	3.18	25.40
J	K	L	M	N	P	Q	wt
--	--	.125	1.688	2.18	.75	.07	grams
--	--	3.18	42.88	55.37	19.05	1.78	70.0

Electrical Schematic

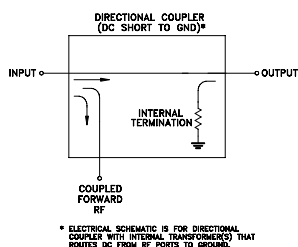

Features

- very wideband, 10 to 1800 MHz
- excellent directivity, 25 dB typ.
- rugged shielded case

Applications

- cellular
- instrumentation
- communication receivers & transmitters
- GPS

Connectors	Model	Price	Qty.
BNC	ZFDC-10-182+	\$59.95	(1-9)
SMA	ZFDC-10-182-S+	\$59.95	(1-9)
N-TYPE	ZFDC-10-182-N+	\$64.95	(1-9)
BRACKET (OPTION "B")		\$5.00	(1+)

+RoHS Compliant

The +Suffix identifies RoHS Compliance. See our web site for RoHS Compliance methodologies and qualifications

Electrical Specifications at 25°C

Parameter	Condition (MHz)	Min.	Typ.	Max.	Unit
Frequency Range		10	—	1800	MHz
Mainline Loss (above theoretical 0.46 dB)	10	—	0.8	1.4	dB
	700	—	1.0	1.7	
	1800	—	1.4	2.4	
Coupling	10-1800	—	10.4	—	dB
	10	9.7	9.9	10.2	
	700	9.8	10.5	11.2	
Coupling Flatness(±)	10-700	—	0.3	0.5	dB
	700-1800	—	0.3	0.5	
	1800	9.4	10.8	11.9	
Directivity	10	22.0	27.0	—	dB
	700	22.0	31.7	—	
	1800	18.0	24.1	—	
Return Loss (Input)	10	15.0	18.2	—	dB
	700	18.0	22.6	—	
	1800	15.0	20.0	—	
Return Loss (Output)	10	22.0	29.7	—	dB
	700	20.0	29.1	—	
	1800	15.0	19.3	—	
Return Loss (Coupling)	10	22.0	30.0	—	dB
	700	18.0	22.4	—	
	1800	10.0	12.5	—	
Input Power	10-1800	—	—	0.5	W

Typical Performance Data

Frequency (MHz)	Mainline Loss (dB) In-Out	Coupling (dB) In-Cpl	Directivity (dB)	Return Loss (dB)		
				In	Out	Cpl
10.00	1.22	9.89	27.67	18.18	31.31	32.50
50.00	1.25	9.92	28.35	18.31	34.64	39.67
100.00	1.28	9.96	28.81	18.43	34.63	36.08
500.00	1.33	10.24	33.19	20.63	34.98	27.15
700.00	1.34	10.36	37.70	22.46	33.85	26.28
1000.00	1.35	10.47	31.47	26.62	31.16	23.80
1200.00	1.37	10.51	27.39	29.41	29.15	20.72
1400.00	1.40	10.56	24.85	28.21	26.75	17.58
1500.00	1.43	10.60	24.01	26.51	25.54	16.16
1800.00	1.57	10.86	22.35	22.44	22.89	12.56

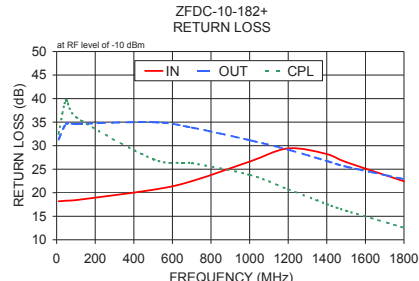
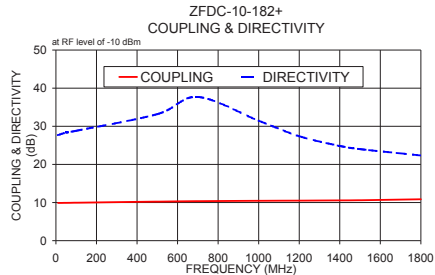
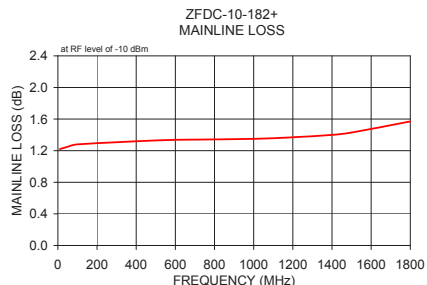

Mini-Circuits®
ISO 9001 ISO 14001 AS 9100 CERTIFIED
IF/RF MICROWAVE COMPONENTS

For detailed performance specs & shopping online see web site

P.O. Box 350166, Brooklyn, New York 11235-0003 (718) 934-4500 Fax (718) 332-4661 The Design Engineers Search Engine Provides ACTUAL Data Instantly at minicircuits.com

Notes: 1. Performance and quality attributes and conditions not expressly stated in this specification sheet are intended to be excluded and do not form a part of this specification sheet. 2. Electrical specifications and performance data contained herein are based on Mini-Circuit's applicable established test performance criteria and measurement instructions. 3. The parts covered by this specification sheet are subject to Mini-Circuits standard limited warranty and terms and conditions (collectively, "Standard Terms"); Purchasers of this part are entitled to the rights and benefits contained therein. For a full statement of the Standard Terms and the exclusive rights and remedies thereunder, please visit Mini-Circuits' website at www.minicircuits.com/MCLStore/terms.jsp.

REV. OR
M116994
ZFDC-10-182+
ED-13361/1
WZ/CP/AM
110131