

Surface Mount Directional Coupler

SYDC-20-61VHP+

50Ω 20 dB Coupling 1.5 to 60 MHz 40 Watt



CASE STYLE: AH1503

The Big Deal

- Very High Input Power, 40W1
- Very low insertion loss, 0.1 dB2
- Very Flat Coupling, 0.1 dB
- Very High Directivity, 30 dB

Product Overview

SYDC-20-61VHP+ is a high power, low cost surface mount directional coupler, operating over 1.5-60 MHz, using an open case construction to lower size, measuring 0.63" x 0.43" x 0.36" (16 mm x 11 mm x 9 mm). Ground plane at the bottom of the unit serves as an excellent heat sink to minimize temperature rise.

Feature	Advantages
Very High Input Power: 40 Watt	Designed for monitoring of output power of transmitters with minimal power loss.
Very Low Loss: 0.1 dB typ.	Low loss minimizes the loss of transmit power and temperature rise of surrounding components, thus preserving performance and improving reliability.
Very Flat coupling: ± 0.1 dB	Flat Coupling over the entire frequency range eliminating need for compensation circuits.
High Directivity: 22-40 dB typ.	Minimizes the undesired power entering the coupled port due to imperfect load impedance.
Excellent Return loss: 20-40 dB typ.	Excellent Return loss of SYDC minimizes interaction effects with adjacent circuits and resulting gain ripple.

Notes

- A. Performance and quality attributes and conditions not expressly stated in this specification document are intended to be excluded and do not form a part of this specification document.
B. Electrical specifications and performance data contained in this specification document are based on Mini-Circuit's applicable established test performance criteria and measurement instructions.
C. The parts covered by this specification document are subject to Mini-Circuits standard limited warranty and terms and conditions (collectively, "Standard Terms"); Purchasers of this part are entitled to the rights and benefits contained therein. For a full statement of the Standard Terms and the exclusive rights and remedies thereunder, please visit Mini-Circuits' website at www.minicircuits.com/MCLStore/terms.jsp



Surface Mount Directional Coupler

50Ω 20 dB Coupling 1.5 to 60 MHz 40 Watt

SYDC-20-61VHP+



CASE STYLE: AH1503
PRICE: \$49.95 ea. QTY (1-9)

+RoHS Compliant

The +Suffix identifies RoHS Compliance. See our web site for RoHS Compliance methodologies and qualifications

Maximum Ratings

Operating Temperature -40°C to 85°C Case*
Storage Temperature -55°C to 100°C

* Case temperature is defined as temperature on ground leads.
Permanent damage may occur if any of these limits are exceeded.

Pin Connections

INPUT	1
OUTPUT	8
COUPLED	4
50Ω TERM EXTERNAL*	5
GROUND	2,3,6,7

* External termination must be able to handle 250 mW min.

Outline Drawing

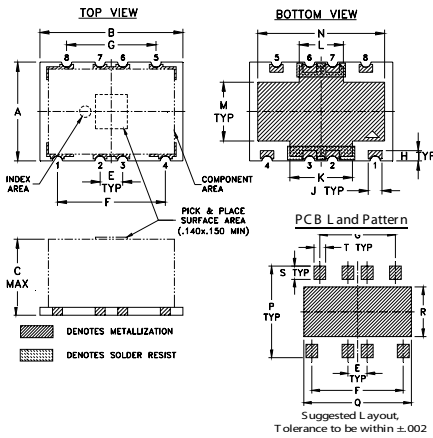

Outline Dimensions (inch/mm)

A	B	C	E	F	G	H	J	K
.433	.630	.355	.100	.476	.394	.045	.060	.276
11.00	16.00	9.02	2.54	12.09	10.01	1.14	1.52	7.01
L	M	N	P	Q	R	S	T	wt
.194	.257	.560	.475	.561	.258	.069	.061	grams
4.93	6.53	14.22	12.07	14.25	6.55	1.75	1.55	2.50

Demo Board MCL P/N: TB-570+ Suggested PCB Layout (PL-330)

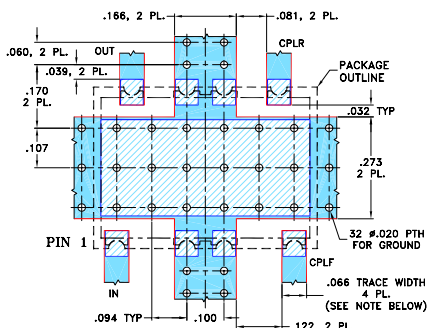

NOTES: 1. TRACE WIDTH IS SHOWN FOR ROGERS RO4350B WITH DIELECTRIC THICKNESS .030" ± .002"; COPPER: 1/2 OZ. EACH SIDE. FOR OTHER MATERIALS TRACE WIDTH MAY NEED TO BE MODIFIED.
2. BOTTOM SIDE OF THE PCB IS CONTINUOUS GROUND PLANE.

- Denotes PCB COPPER LAYOUT WITH SMOBC (SOLDER MASK OVER BARE COPPER)
- Denotes COPPER LAND PATTERN FREE OF SOLDER MASK

Notes

A. Performance and quality attributes and conditions not expressly stated in this specification document are intended to be excluded and do not form a part of this specification document.
B. Electrical specifications and performance data contained in this specification document are based on Mini-Circuit's applicable established test performance criteria and measurement instructions.
C. The parts covered by this specification document are subject to Mini-Circuit's standard limited warranty and terms and conditions (collectively, "Standard Terms"); Purchasers of this part are entitled to the rights and benefits contained therein. For a full statement of the Standard Terms and the exclusive rights and remedies thereunder, please visit Mini-Circuit's website at www.minicircuits.com/MCLStore/terms.jsp

Features

- high power, 40W max. with output load VSWR 2.0 max
- high power, 20W max. with output open or short
- low mainline loss, 0.1 dB typ.
- good VSWR, 1.05 typ.

Applications

- military mobile

Electrical Specifications at 25°C

Parameter	Condition (MHz)	Min.	Typ.	Max.	Unit
Frequency Range		1.5	—	60	MHz
Mainline Loss¹ (above theoretical 0.04 dB)	1.5		0.1	0.1	dB
	30		0.1	0.2	
	60		0.1	0.2	
Coupling	1.5-60		21.0		dB
	1.5	20.5	20.9	21.4	
	30	20.5	21.0	21.5	
Coupling Flatness(±)	1.5-30		0.1	0.3	dB
	30-60		0.1	0.3	
	60		0.1	0.3	
Directivity	1.5	28	42.5	—	dB
	30	22	30.5	—	
	60	16	22.7	—	
Return Loss (Input)	1.5	28	42	—	dB
	30	25	41	—	
	60	19	37	—	
Return Loss (Output)	1.5	28	43	—	dB
	30	25	39	—	
	60	19	33	—	
Return Loss (Coupling)	1.5	30	41	—	dB
	30	20	26	—	
	60	16	20	—	
Input Power¹				40	W

1. The user must provide adequate means of heat removal to limit the temperature of ground connections 2,3,6,7 to 85°C, in order to ensure proper performance. At 25°C ambient temperature this requires thermal resistance of the user's PC board heat sink to be 40°C/W or less when the unit is driven at maximum specified RF input power, 40W. At higher ambient temperature, with the same heat sink, input power in watts must not exceed 40W x (85°C-T_{AMBIENT}) ÷ 60°C.

Typical Performance Data

Frequency (MHz)	Mainline Loss (dB)		Coupling (dB) In-Cpl	Directivity (dB)	Return Loss (dB)		
	In-Out	In-Cpl			In	Out	Cpl
1.50	0.07	0.07	20.89	42.10	42.83	43.50	41.69
2.00	0.07	0.07	20.90	42.35	44.35	44.45	41.71
4.00	0.08	0.08	20.91	42.43	45.76	44.90	40.48
5.00	0.08	0.08	20.91	42.22	46.17	44.92	39.52
10.00	0.08	0.08	20.92	39.08	46.52	43.05	34.60
20.00	0.10	0.10	20.94	33.83	45.20	40.30	28.62
30.00	0.11	0.11	20.97	30.15	43.81	38.21	25.00
40.00	0.12	0.12	21.00	27.09	42.58	36.30	22.41
50.00	0.13	0.13	21.04	24.42	41.47	34.44	20.38
60.00	0.14	0.14	21.09	22.14	39.72	32.72	18.69

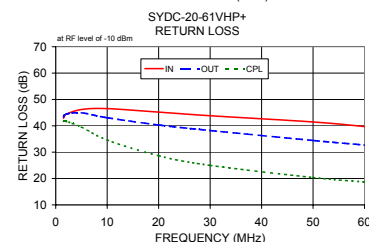
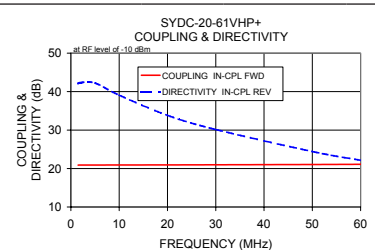
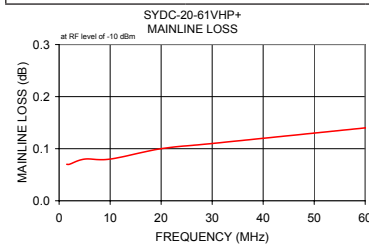

Electrical Schematic

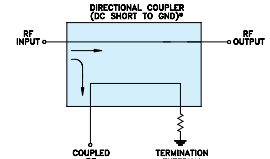

* ELECTRICAL SCHEMATIC IS FOR DIRECTIONAL COUPLER WITH INTERNAL TRANSFORMER(S) AND EXTERNAL TERMINATION

