

50Ω 6 to 18 GHz



CASE STYLE: GC957

The Big Deal

- Wideband, 6-18 GHz
- High Gain, Very Flat Response, 24 dB \pm 1.0 dB typ.
- Excellent Isolation, 62 dB typ.
- Unconditionally Stable performance

Product Overview

The ZX60-183+ two-stage amplifier provides high gain in a very small package, only 0.75" x 0.74" x 0.46" high. Internal compensating circuitry provides a consistent, very flat response over the full bandwidth. Designed for 50 Ω SMA coax systems, the gold-plated package uses convenient 5V DC power, and has a nickel-plated brass cover and unibody construction for rugged use.

Key Features

Feature	Advantages
Wideband, 6-18 GHz	Wide frequency range supports a wide array of applications, from microwave radio and radar to military communications, satellite communications, and countermeasures
Excellent Gain Flatness	\pm 1.0 dB gain flatness across entire bandwidth minimizes the need for external equalizer networks, making it a great fit for instrumentation, test lab, EW, or any other amplitude-sensitive system
High Gain and Excellent Isolation	24 dB gain with reverse isolation of 62 dB (38 dB directivity) prevents leakage, making the ZX60-183+ an excellent choice for minimizing interactions between different microwave components. It is an ideal LO driver amplifier and provides designers system flexibility and robustness when integrating cascaded RF components
Unconditionally Stable	No risk of damage to other components from impedance mismatch or internal oscillation

Wideband Microwave Amplifier

ZX60-183+**50Ω 6 to 18 GHz****Features**

- wideband, 6 to 18 GHz
- gain, 24 dB typ and flatness, ± 1.0 dB typ.
- output power at 1 dB compression, 18.0 dBm typ.
- excellent isolation, 62 dB typ.
- unconditionally stable
- protected by US patent 6,790,049

Applications

- military and radar
- DBS
- wideband isolation amplifier
- microwave point to point radio
- satellite systems



CASE STYLE: GC957

Connectors	Model	Price	Qty.
SMA	ZX60-183-S+	\$169.95 ea.	(1-9)

+ RoHS compliant in accordance with EU Directive (2002/95/EC)

The +Suffix has been added in order to identify RoHS Compliance. See our web site for RoHS Compliance methodologies and qualifications.

Electrical Specifications at 25°C

Parameter	Condition (GHz)	Min.	Typ.	Max.	Units
Frequency Range		6.0		18.0	GHz
Gain	6.0		24.2		dB
	8.0	18.5	24.3		
	10.0	18.5	23.5		
	12.0		23.5		
	14.0		23.4		
	16.0		22.7		
	18.0	18.5	24.0		
Gain Flatness	6.0-18.0		± 1.0		dB
Input Return Loss	6.0		16.3		dB
	8.0	10.0	16.5		
	10.0		12.2		
	12.0	10.0	15.7		
	14.0		11.0		
	16.0		11.8		
	18.0		11.0		
Output Return Loss	6.0		22.2		dB
	8.0	10.0	17.2		
	10.0		13.8		
	12.0	10.0	15.9		
	14.0	10.0	22.8		
	16.0		15.0		
	18.0	10.0	26.6		
Output IP3	6.0		27.4		dBm
	8.0		27.7		
	10.0		27.9		
	12.0		27.2		
	14.0		26.9		
	16.0		27.1		
	18.0		26.4		
Output Power @ 1 dB compression	6.0		18.0		dBm
	8.0		18.3		
	10.0	16.0	18.5		
	12.0		18.1		
	14.0		17.6		
	16.0		18.0		
	18.0		18.0		
Noise Figure	6.0		8.2		dB
	8.0		6.9		
	10.0		6.3		
	12.0		6.9		
	14.0		6.8		
	16.0		6.8		
	18.0		6.5		
Directivity (Isolation-Gain)			38		dB
DC Voltage			5.0		V
DC Current			260	290	mA

Maximum Ratings

Parameter	Ratings
Operating Temperature	-40°C to 85°C Base Plate Temp.
Storage Temperature	-55°C to 100°C
DC Voltage	5.5V
Input RF Power (no damage)	+20 dBm
Power Dissipation	1.6 W

Permanent damage may occur if any of these limits are exceeded.

Outline Drawing

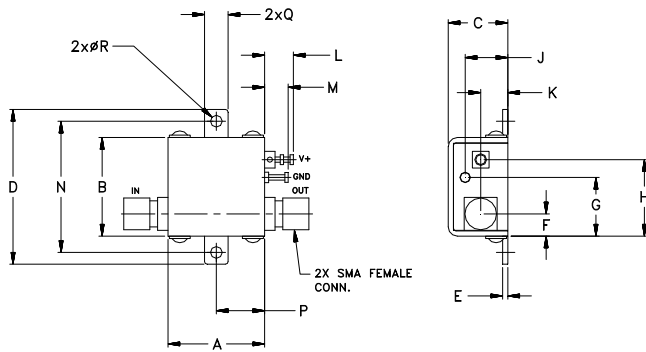

Outline Dimensions (inch/mm)

A	B	C	D	E	F	G	H	J	K	L	M	N	P	Q	R	wt
.74	.75	.46	1.18	.04	.17	.45	.59	.33	.21	.22	.18	1.00	.37	.18	.106	grams
18.80	19.05	11.68	29.97	1.02	4.32	11.43	14.99	8.38	5.33	5.59	4.57	25.40	9.40	4.57	2.69	23.0

FREQUENCY (MHz)	GAIN (dB)	DIRECTIVITY	VSWR IN (:1)	VSWR OUT (:1)	POWER OUT @1 dB COMPR. (dBm)	IP3 (dBm)	NF (dB)
6000.00	24.24	43.74	1.13	1.23	17.80	27.78	7.40
7000.00	24.13	41.84	1.06	1.31	18.44	27.98	7.03
8000.00	24.19	38.28	1.26	1.47	18.49	27.72	6.90
9000.00	23.91	36.50	1.57	1.62	18.73	27.47	7.08
10000.00	23.19	39.89	1.67	1.64	18.63	27.76	6.37
11000.00	23.09	45.13	1.64	1.56	18.43	27.26	7.21
12000.00	23.23	40.13	1.41	1.36	18.13	27.49	7.01
13000.00	23.36	40.96	1.21	1.15	17.90	27.48	6.89
14000.00	23.22	38.51	1.32	1.20	17.34	27.34	6.82
15000.00	22.74	38.10	1.57	1.48	17.28	27.40	6.90
16000.00	22.47	39.63	1.59	1.63	17.84	27.64	6.77
17000.00	23.02	44.13	1.39	1.51	17.47	27.12	7.56
18000.00	23.73	39.26	1.43	1.20	18.24	26.71	6.59

