

# Super Ultra Wideband Amplifier

## ZVA-183W+

50Ω 0.1 to 18 GHz

### Features

- Wideband, 0.1 to 18 GHz
- High IP3, 36 dBm typ.
- High power output, +26 dBm
- High flat gain, 27±2 dB typ.

### Applications

- Radar and military
- Test instrumentation
- Satellite repeaters
- Communication



Model No.	ZVA-183W+	▲ ZVA-183WX+
Case Style	CP1755	
Connectors	SMA	
Price (Qty.)	\$1395.00 ea. (1-9)	\$1345.00 ea. (1-9)

#### +RoHS Compliant

The +Suffix identifies RoHS Compliance. See our web site for RoHS Compliance methodologies and qualifications

### Product Description

ZVA-183W+ is a Class-A, four stage, unconditionally stable amplifier. It features a ruggedized case, available with and without a heat sink/fan, and has the capability to withstand accidental open or short at output and is protected against reverse bias protection for added reliability under difficult conditions.

### Electrical Specifications at 25°C

Parameter	Condition (MHz)	ZVA-183W+ ▲ ZVA-183WX+			Units
		Min.	Typ.	Max.	
Frequency Range		100	—	18000	MHz
Gain	100 - 6000	25	29	34	dB
	6000 - 18000	24	27	33	
Gain Flatness	100 - 6000	—	±2	±2.5	dB
	6000 - 18000	—	±1.0	±1.8	
Output Power at 1dB compression	100 - 6000	24.5	27	—	dBm
	6000 - 18000	24.5	26	—	
Noise Figure	500 - 18000	—	3	6	dB
Output third order intercept point	100 - 6000	—	+36	—	dBm
	6000 - 18000	—	+33	—	
Input VSWR	100 - 18000	—	1.3	2.0	:1
Output VSWR	100 - 18000	—	1.6	2.2	:1
DC Supply Voltage		14	15*	15.5	V
Supply Current†		—	625	700	mA

† Power Supply should be capable of delivering 1A at start-up.

\* Recommended Operating Voltage.

▲ Heat sink not included. Alternative heat sinking and heat removal must be provided by the user to limit maximum base-plate temperature to 85°C, in order to ensure proper performance. For reference, this requires thermal resistance of user's external heat sink to be 1.79°C/W max.

### Maximum Ratings

Parameter	Ratings
Operating Temperature	-55°C to 60°C
Storage Temperature	-65°C to 150°C
Base Plate Temperature	85°C
DC Voltage	15.5V
Input RF Power (no damage)	+20 dBm

Permanent damage may occur if any of these limits are exceeded.



P.O. Box 350166, Brooklyn, New York 11235-0003 (718) 934-4500 Fax (718) 332-4661 The Design Engineers Search Engine  Provides ACTUAL Data Instantly at [minicircuits.com](http://minicircuits.com)

IFIRF MICROWAVE COMPONENTS

For detailed performance specs & shopping online see web site

Notes: 1. Performance and quality attributes and conditions not expressly stated in this specification sheet are intended to be excluded and do not form a part of this specification sheet. 2. Electrical specifications and performance data contained herein are based on Mini-Circuit's applicable established test performance criteria and measurement instructions. 3. The parts covered by this specification sheet are subject to Mini-Circuits standard limited warranty and terms and conditions (collectively, "Standard Terms"); Purchasers of this part are entitled to the rights and benefits contained therein. For a full statement of the Standard Terms and the exclusive rights and remedies thereunder, please visit Mini-Circuits' website at [www.minicircuits.com/MCLStore/terms.jsp](http://www.minicircuits.com/MCLStore/terms.jsp).

REV. OR  
M138394  
ZVA-183W+  
ED-14815/1  
WZ/CP/AM  
120831  
Page 2 of 4

## Outline Drawing for models with heatsink

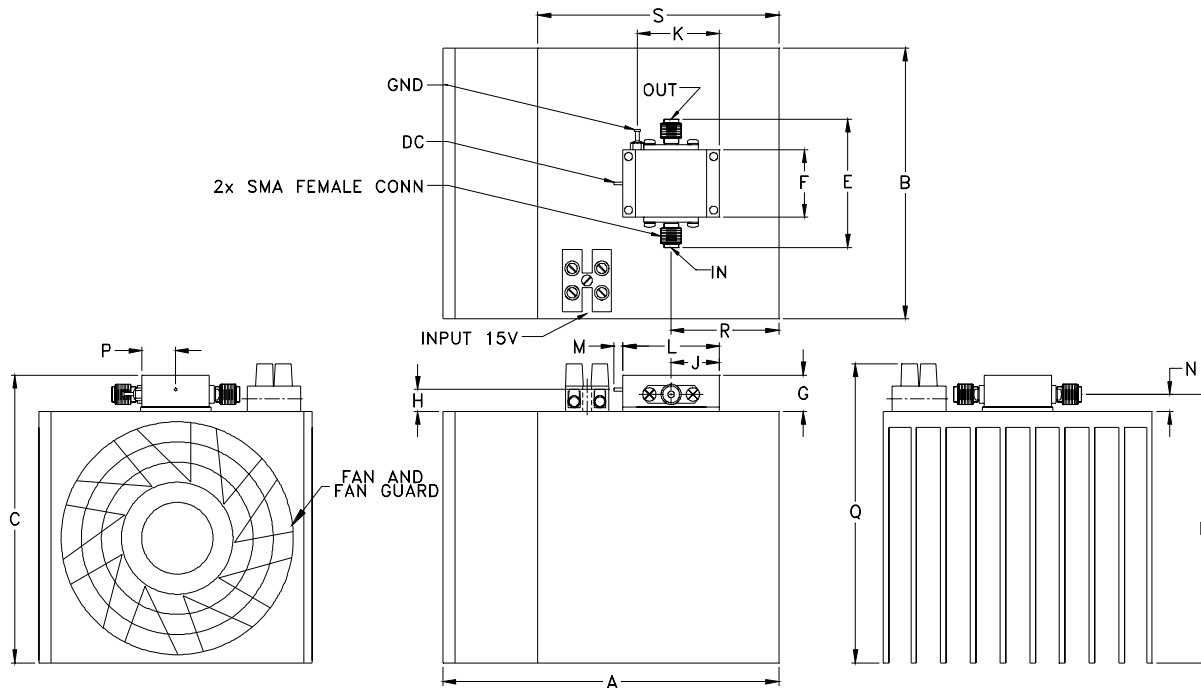

## Outline Drawing for models without heatsink

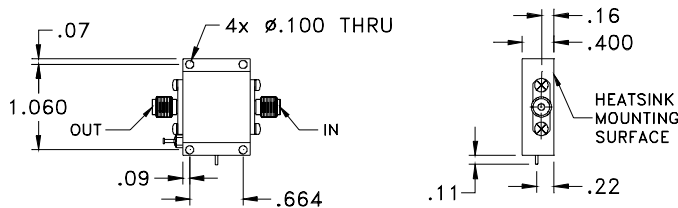

HEAT SPREADER PLATE AND MOUNTING HARDWARE INCLUDED WITH MODELS WITHOUT HEATSINK

## Outline Dimensions (inch/mm)

A	B	C	D	E	F	G	H	J	K	L	M	N	P	Q	R	S	wt
4.18	3.36	3.57	3.33	1.59	.840	.45	0.27	.600	1.02	1.200	.11	.21	.420	3.71	1.34	3.00	grams*
106.17	85.34	90.68	84.58	40.39	21.34	11.43	6.86	15.24	25.91	30.48	2.79	5.33	10.67	94.23	34.04	76.20	480
*18.2 grams without heatsink																	

FREQUENCY (MHz)	GAIN (dB)	DIRECTIVITY (dB)	VSWR (:1)		POUT at 1 dB COMPR. (dBm)	NOISE FIGURE (dB)	IP3 (dBm)
	15V	15V	IN	OUT	15V	15V	15V
100.00	30.46	45.70	1.30	1.40	25.84	8.87	36.63
1000.00	30.45	47.11	1.30	1.68	27.32	4.51	40.53
2000.00	28.64	37.01	1.27	1.63	27.39	4.02	39.80
3000.00	28.93	31.34	1.25	1.26	27.73	3.46	40.28
4000.00	27.44	41.05	1.20	1.08	27.19	3.19	39.35
5000.00	28.01	42.69	1.18	1.17	27.79	2.98	40.31
6000.00	27.10	31.48	1.13	1.07	27.46	2.69	39.44
7000.00	28.14	36.44	1.14	1.14	27.70	2.37	39.20
8000.00	27.69	42.96	1.11	1.21	27.25	2.57	38.18
9000.00	28.01	40.06	1.18	1.23	27.24	2.73	37.89
10000.00	27.25	40.50	1.19	1.15	27.24	3.19	37.06
11000.00	26.63	42.63	1.23	1.15	26.59	3.53	36.23
12000.00	26.73	40.00	1.40	1.42	25.87	3.75	35.52
14000.00	26.85	28.10	1.28	1.49	25.97	3.82	34.24
16000.00	27.57	35.72	1.11	1.31	25.90	4.25	33.98
18000.00	26.16	30.26	1.23	1.29	26.12	4.60	32.60

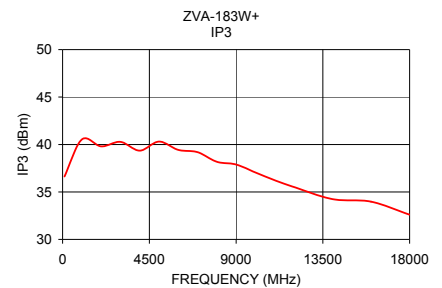
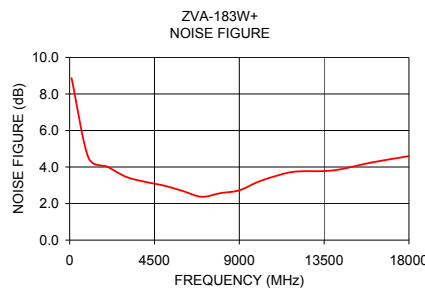
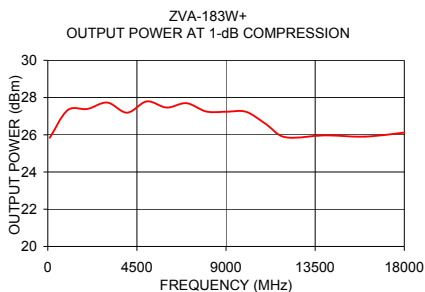
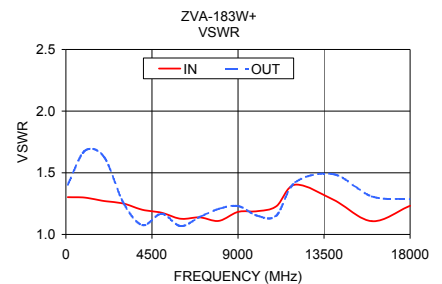
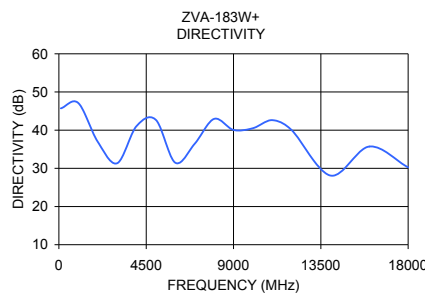
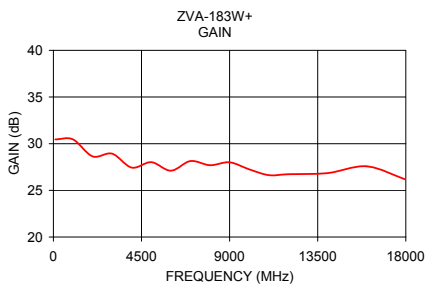

For detailed performance specs & shopping online see web site

P.O. Box 350166, Brooklyn, New York 11235-0003 (718) 934-4500 Fax (718) 332-4661 The Design Engineers Search Engine  Provides ACTUAL Data Instantly at [minicircuits.com](http://minicircuits.com)

IF/RF MICROWAVE COMPONENTS

Notes: 1. Performance and quality attributes and conditions not expressly stated in this specification sheet are intended to be excluded and do not form a part of this specification sheet. 2. Electrical specifications and performance data contained herein are based on Mini-Circuit's applicable established test performance criteria and measurement instructions. 3. The parts covered by this specification sheet are subject to Mini-Circuits standard limited warranty and terms and conditions (collectively, "Standard Terms"); Purchasers of this part are entitled to the rights and benefits contained therein. For a full statement of the Standard Terms and the exclusive rights and remedies thereunder, please visit Mini-Circuits' website at [www.minicircuits.com/MCLStore/terms.jsp](http://www.minicircuits.com/MCLStore/terms.jsp).