

Coaxial Amplifier

ZFL-1000VH+

50Ω Medium Power 10 to 1000 MHz

Features

- wideband, 10 to 1000 MHz
- low noise, 4.5 dB typ.
- high IP3, +38 dBm typ.

Applications

- cellular
- VHF/UHF
- test equipment



| Connectors | Model | Price | Qty. |
|----------------------|--------------|--------------|-------|
| SMA | ZFL-1000VH+ | \$229.00 ea. | (1-9) |
| BRACKET (OPTION "B") | | \$5.00 | (1+) |
| SMA | ZFL-1000VHX+ | \$219.00 ea. | (1-9) |

+RoHS Compliant
The +Suffix identifies RoHS Compliance. See our web site for RoHS Compliance methodologies and qualifications

Amplifier Electrical Specifications

| MODEL NO. | FREQUENCY (MHz) | | GAIN (dB) | | MAXIMUM POWER (dBm) | | DYNAMIC RANGE | | VSWR (:1) Typ. | | DC POWER | |
|---------------|-----------------|-------|-----------|---------------|----------------------|-------------------|---------------|----------------|-----------------|-----|---------------|-------------------|
| | f_L | f_U | Min. | Flatness Max. | Output (1 dB Compr.) | Input (no damage) | NF (dB) Typ. | IP3 (dBm) Typ. | In ¹ | Out | Volt (V) Nom. | Current (mA) Max. |
| ZFL-1000VH+ | 10 | 1000 | 20 | ±1.0 | +25 | +15 | 4.5 | +38 | 2.0 | 2.5 | 15 | 320 |
| ZFL-1000VHX+* | 10 | 1000 | 20 | ±1.0 | +25 | +15 | 4.5 | +38 | 2.0 | 2.5 | 15 | 320 |

* Heat sink not included.
¹ Input VSWR 2:1 Max. increasing below 20 MHz to 2.25:1 max. at 10 MHz
 Open load is not recommended, potentially can cause damage.
 With no load derate max input power by 20 dB

To order without heat sink, add suffix X to model number. Alternative heat sinking and heat removal must be provided by the user to limit maximum temperature to 71°C, in order to ensure proper performance. For reference, this requires thermal resistance of user's external heat sink to be 8°C/W Max.

Maximum Ratings

| | |
|-----------------------|----------------|
| Operating Temperature | -20°C to 71°C |
| Storage Temperature | -55°C to 100°C |
| DC Voltage | +17V Max. |

Permanent damage may occur if any of these limits are exceeded.

Outline Drawing

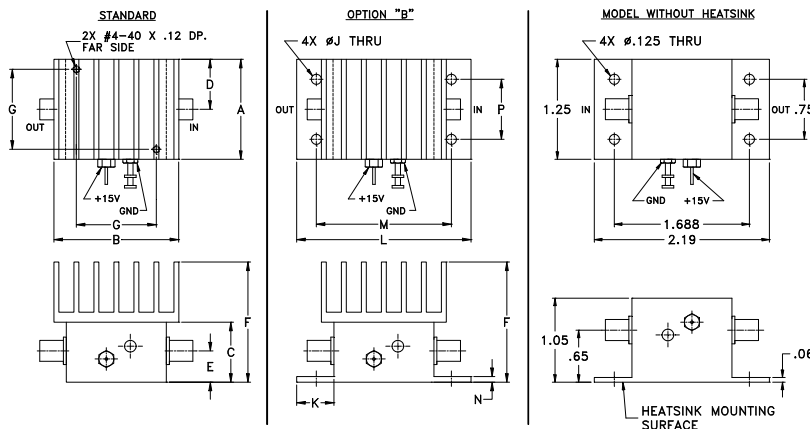

Outline Dimensions (inch/mm)

| A | B | C | D | E | F | G | H | J | K | L | M | N | P | wt* |
|-------|-------|-------|-------|------|-------|-------|----|------|-------|-------|-------|------|-------|-------|
| 1.25 | 1.56 | .75 | .63 | .39 | 1.50 | 1.000 | -- | .125 | .46 | 2.19 | 1.688 | .06 | .750 | grams |
| 31.75 | 39.62 | 19.05 | 16.00 | 9.91 | 38.10 | 25.40 | -- | 3.18 | 11.68 | 55.63 | 42.88 | 1.52 | 19.05 | |

*70 grams without heat sink

Notes

- Performance and quality attributes and conditions not expressly stated in this specification document are intended to be excluded and do not form a part of this specification document.
- Electrical specifications and performance data contained in this specification document are based on Mini-Circuit's applicable established test performance criteria and measurement instructions.
- The parts covered by this specification document are subject to Mini-Circuits standard limited warranty and terms and conditions (collectively, "Standard Terms"); Purchasers of this part are entitled to the rights and benefits contained therein. For a full statement of the Standard Terms and the exclusive rights and remedies thereunder, please visit Mini-Circuits' website at www.minicircuits.com/MCLStore/terms.jsp

| FREQUENCY (MHz) | GAIN (dB) | | | DIRECTIVITY (dB) | | | VSWR (:1) | | NOISE FIGURE (dB) | POUT at 1 dB COMPR. (dBm) |
|-----------------|-----------|-------|-------|------------------|-------|-------|-----------|------|-------------------|---------------------------|
| | 12V | 15V | 16V | 12V | 15V | 16V | IN | OUT | | |
| 10.00 | 21.30 | 21.45 | 21.46 | 19.10 | 19.40 | 19.30 | 1.29 | 1.86 | 4.70 | 26.78 |
| 17.20 | 21.25 | 21.45 | 21.47 | 19.00 | 19.30 | 18.70 | 1.18 | 1.74 | 4.68 | 27.09 |
| 38.80 | 21.28 | 21.49 | 21.52 | 18.80 | 18.90 | 18.80 | 1.11 | 1.70 | 4.61 | 27.16 |
| 87.60 | 21.36 | 21.56 | 21.60 | 18.80 | 19.00 | 18.60 | 1.09 | 1.69 | 4.62 | 27.15 |
| 197.60 | 21.40 | 21.60 | 21.65 | 18.60 | 18.50 | 18.60 | 1.10 | 1.62 | 4.60 | 27.25 |
| 365.40 | 21.44 | 21.68 | 21.73 | 18.00 | 17.80 | 17.90 | 1.13 | 1.46 | 4.76 | 27.69 |
| 441.50 | 21.46 | 21.72 | 21.77 | 17.50 | 17.50 | 17.30 | 1.13 | 1.37 | 4.82 | 27.74 |
| 517.70 | 21.48 | 21.74 | 21.81 | 16.90 | 17.10 | 17.30 | 1.13 | 1.29 | 4.87 | 27.50 |
| 568.50 | 21.44 | 21.72 | 21.79 | 17.00 | 16.70 | 17.00 | 1.12 | 1.26 | 4.90 | 27.38 |
| 619.20 | 21.45 | 21.75 | 21.82 | 16.70 | 16.50 | 16.80 | 1.11 | 1.25 | 4.94 | 27.14 |
| 695.40 | 21.45 | 21.75 | 21.83 | 16.30 | 16.30 | 16.30 | 1.09 | 1.28 | 5.00 | 27.04 |
| 771.50 | 21.49 | 21.80 | 21.89 | 15.60 | 15.70 | 15.50 | 1.08 | 1.35 | 5.09 | 26.93 |
| 847.70 | 21.63 | 21.96 | 22.04 | 14.80 | 15.10 | 15.10 | 1.06 | 1.44 | 5.24 | 26.89 |
| 923.80 | 21.87 | 22.22 | 22.31 | 14.30 | 14.10 | 14.20 | 1.06 | 1.57 | 5.40 | 26.85 |
| 1000.00 | 21.89 | 22.28 | 22.38 | 13.40 | 13.30 | 13.30 | 1.11 | 1.92 | 5.57 | 26.47 |

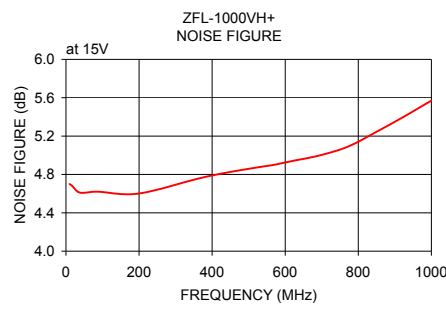
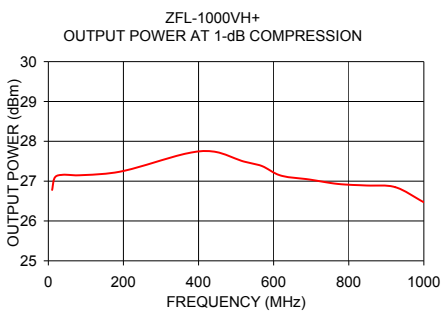
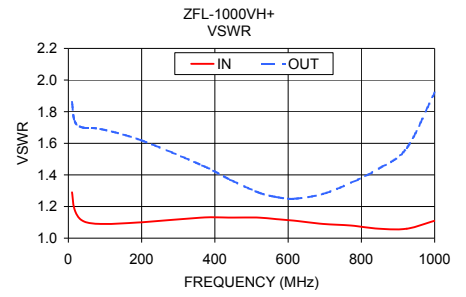
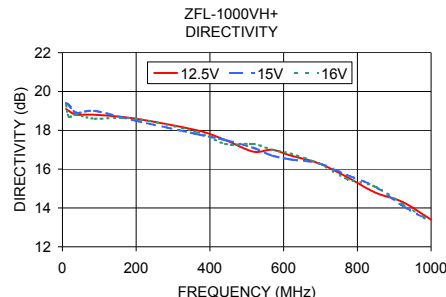
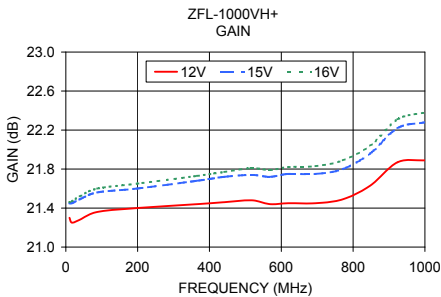

Notes

- A. Performance and quality attributes and conditions not expressly stated in this specification document are intended to be excluded and do not form a part of this specification document.
- B. Electrical specifications and performance data contained in this specification document are based on Mini-Circuit's applicable established test performance criteria and measurement instructions.
- C. The parts covered by this specification document are subject to Mini-Circuits standard limited warranty and terms and conditions (collectively, "Standard Terms"); Purchasers of this part are entitled to the rights and benefits contained therein. For a full statement of the Standard Terms and the exclusive rights and remedies thereunder, please visit Mini-Circuits' website at www.minicircuits.com/MCLStore/terms.jsp

