

Low Noise Amplifier

TAMP-1521GLN+

50Ω 1380 to 1520 MHz

The Big Deal

- Ultra Low Noise Figure, 0.6 dB typ.
- High IP3, 27.5 dBm typ.
- High Gain, 35 dB typ.
- Integrated Bias Matching and Stability Circuits

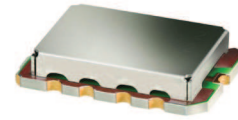

CASE STYLE: JQ1382

Product Overview

The TAMP-1521GLN+ (RoHS compliant) utilizes advanced E-PHEMT technology in a 2-stage low noise amplifier design built into a shielded case (size: .591"x.394"x.118"). The drop-in module offers ultra low noise figure and high gain with good input and output return loss over the entire frequency range and without the need of external matching components.

Key Features

Feature	Advantages
Ultra Low NF	With only 0.6 dB NF, the TAMP-1521GLN+ enables greater sensitivity for receiver applications. It includes all matching and stability circuits making this Drop-in LNA module a turn-key solution for ensuring system sensitivity in demanding applications.
High Output IP3	At +27.5 dBm IP3, in combination with its low noise performance, the TAMP-1521GLN+ can improve a systems' spur-free dynamic range which is often the critical driver in many receiver applications.
Very flat, High Gain	With gain of 35 dB and flatness of ± 0.35 dB, this amplifier can insulate a receiver NF from component losses or NF of the 2nd stage amplifier following the TAMP-1521GLN+.
Power In at 1dB Comp.: -20dBm typ. Input no damage, +17dBm	Provides a good safety margin against damage or saturation from unwanted high power RF signals present at the input to a receiver.
Well Matched input/ output ports	With typical return loss of 21 dB at the input and output ports, the TAMP-1521GLN+ can be used in cascade with many 50 Ohm components and maintain minimal interaction or reflections.
Drop-in Module	Eliminates the need for designers to optimize low noise transistor bias and matching circuitry. The TAMP-1521GLN+ provides the outstanding combined performance and does not require any external elements. The case PCB area is smaller than most LNA transistor designs with external circuitry.
Metal Case	Provides a protective enclosure improving handling robustness in addition to shielding the sensitive high gain devices from close by circuitry.
Unconditionally stable	No adverse effects due to loading of the input and output ports avoiding potential instability which can be a critical requirement when integrating high gain, high frequency devices on an open PCB assembly.



For detailed performance specs & shopping online see web site

P.O. Box 350166, Brooklyn, New York 11235-0003 (718) 934-4500 Fax (718) 332-4661 The Design Engineers Search Engine  Provides ACTUAL Data Instantly at minicircuits.com
IF/RF MICROWAVE COMPONENTS

Notes: 1. Performance and quality attributes and conditions not expressly stated in this specification sheet are intended to be excluded and do not form a part of this specification sheet. 2. Electrical specifications and performance data contained herein are based on Mini-Circuit's applicable established test performance criteria and measurement instructions. 3. The parts covered by this specification sheet are subject to Mini-Circuits standard limited warranty and terms and conditions (collectively, "Standard Terms"); Purchasers of this part are entitled to the rights and benefits contained therein. For a full statement of the Standard Terms and the exclusive rights and remedies thereunder, please visit Mini-Circuits' website at www.minicircuits.com/MCLStore/terms.jsp.

Surface Mount

Low Noise Amplifier

TAMP-1521GLN+

50Ω

1380 to 1520 MHz

Features

- Ultra low noise figure, 0.6 dB typ.
- High gain, 35 dB typ.
- Output power, up to +13.5 dBm typ.
- Good output IP3, 27.5 dBm typ.
- Good VSWR, 1.2:1 typ.
- Unconditionally stable

Applications

- Military & Avionics
- Base station transceiver, tower mounted amplifier, repeater
- General purpose low noise amplifier

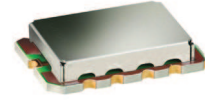

CASE STYLE: JQ1382
 PRICE: \$14.95 ea. QTY (5-49)

+RoHS Compliant
The +Suffix identifies RoHS Compliance. See our web site for RoHS Compliance methodologies and qualifications

Electrical Specifications at 25°C

Parameter	Condition (MHz)	Min.	Typ.	Max.	Units
Frequency Range		1380		1520	MHz
Noise Figure	1380 - 1520		0.6	0.9	dB
Gain	1380 - 1520	33	35		dB
Gain Flatness	1380 - 1520		± 0.35	± 0.65	dB
Output Power at 1dB compression	1380 - 1520	11.5	13.5		dBm
Output third order intercept point (OIP3)	1380 - 1520		27.5		dBm
Input VSWR	1380 - 1520		1.20		:1
Output VSWR	1380 - 1520		1.15		:1
DC Supply Voltage			5.0		V
DC Supply Current			50	70	mA

Pin Connections

RF IN	10
RF OUT	5
V+	7
GROUND	1,2,3,4,6,8,9,11

Maximum Ratings

Parameter	Ratings
Operating Temperature	-40°C to 85°C
Storage Temperature	-55°C to 100°C
Operating Voltage	5.5 V
Input RF Power (no damage)	+17 dBm
Power Consumption	390 mW

Permanent damage may occur if any of these limits are exceeded.

Simplified Schematic

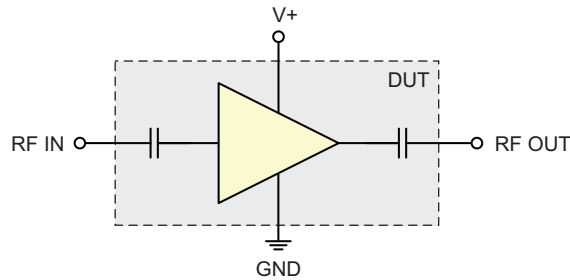

ESD Rating

Human Body Model (HBM): Class 1A (250 V to < 500 V) in accordance with ANSI/ESD STM 5.1 - 2001
 Machine Model (MM): Class M1 (40 V) in accordance with ANSI/ESD STM 5.2 - 1999



P.O. Box 350166, Brooklyn, New York 11235-0003 (718) 934-4500 Fax (718) 332-4661 The Design Engineers Search Engine Provides ACTUAL Data Instantly at minicircuits.com

IF/RF MICROWAVE COMPONENTS

For detailed performance specs & shopping online see web site

Notes: 1. Performance and quality attributes and conditions not expressly stated in this specification sheet are intended to be excluded and do not form a part of this specification sheet. 2. Electrical specifications and performance data contained herein are based on Mini-Circuit's applicable established test performance criteria and measurement instructions. 3. The parts covered by this specification sheet are subject to Mini-Circuits standard limited warranty and terms and conditions (collectively, "Standard Terms"); Purchasers of this part are entitled to the rights and benefits contained therein. For a full statement of the Standard Terms and the exclusive rights and remedies thereunder, please visit Mini-Circuits' website at www.minicircuits.com/MCLStore/terms.jsp.

REV. B
 M130109
 TAMP-1521GLN+
 EDR-10038AMP
 RAV
 121022
 Page 2 of 4

Outline Drawing

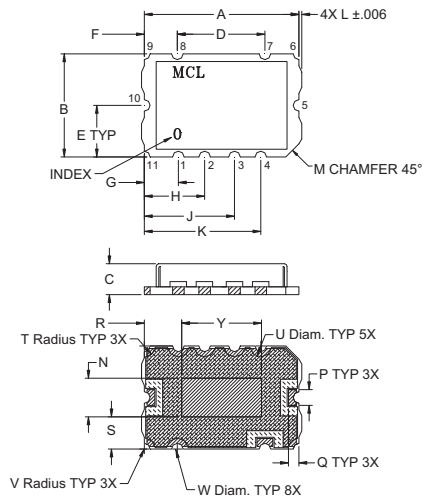

PCB Land Pattern

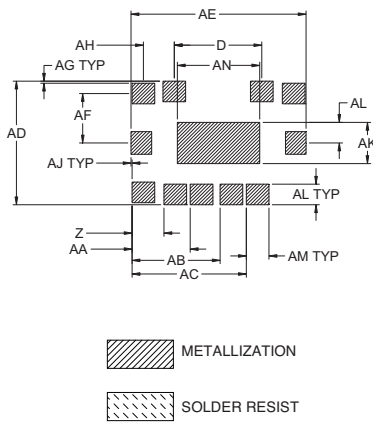

Outline Dimensions (inch / mm)

A	B	C	D	E	F	G	H	J	K	L	M	N	P	Q	R	S	T	U	wt.	
.591	.394	.118	.335	.197	.126	.130	.230	.344	.445	.011	.050	.148	.060	.040	.143	.123	.042	.084		
15.0	10.0	3.0	8.5	5.0	3.2	3.3	5.85	8.75	11.3	.28	1.27	3.75	1.52	1.02	3.63	3.13	1.07	2.13		
V	W	Y	Z	AA	AB	AC	AD	AE	AF	AG	AH	AJ	AK	AL	AM	AN				grams
.022	.044	.305	.122	.222	.337	.437	.472	.669	.189	.008	.118	.004	.158	.079	.087	.315				0.8
.56	1.12	7.75	3.1	5.65	8.55	11.1	12.0	17.0	4.8	.20	3.0	.10	4.0	2.0	2.2	8.0				

Demo Board MCL P/N: TB-468+ Suggested PCB Layout (PL-293)

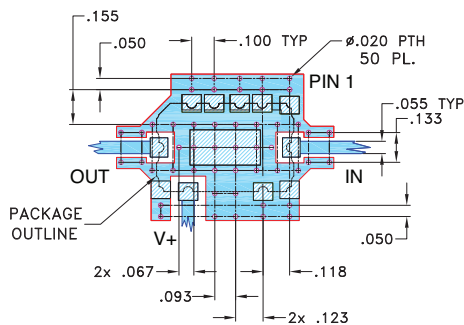

NOTES:

1. TRACE WIDTH IS SHOWN FOR ROGERS RO4350B WITH DIELECTRIC THICKNESS .030" ± .002; COPPER 1/2 OZ. EACH SIDE. FOR OTHER MATERIALS TRACE WIDTH MAY NEED TO BE MODIFIED.
2. BOTTOM SIDE OF THE PCB IS CONTINUOUS GROUND PLANE.

- DENOTES PCB COPPER LAYOUT WITH SMOBC (SOLDER MASK OVER BARE COPPER)
- DENOTES COPPER LAND PATTERN FREE OF SOLDER MASK

FREQUENCY (MHz)	GAIN (dB)	DIRECTIVITY (dB)	VSWR IN (:1)	VSWR OUT (:1)	NOISE FIGURE (dB)	P. OUT @ 1dB COMPR. (dBm)	OUTPUT IP3 (dBm)
1380.00	35.03	14.61	1.20	1.08	0.63	13.71	27.79
1390.00	34.98	14.00	1.19	1.07	0.57	13.79	27.57
1400.00	34.93	14.01	1.19	1.07	0.59	13.62	27.68
1410.00	34.89	14.66	1.18	1.07	0.59	13.70	27.78
1420.00	34.84	13.44	1.17	1.07	0.56	13.73	27.61
1430.00	34.78	13.62	1.16	1.07	0.58	13.65	27.49
1435.00	34.75	14.07	1.16	1.07	0.59	13.66	27.60
1440.00	34.74	14.18	1.15	1.08	0.62	13.65	27.55
1445.00	34.71	13.26	1.15	1.08	0.63	13.71	27.53
1450.00	34.68	14.18	1.15	1.08	0.64	13.65	27.55
1455.00	34.66	13.27	1.14	1.09	0.60	13.49	27.50
1460.00	34.63	13.81	1.14	1.09	0.60	13.54	27.62
1470.00	34.57	13.32	1.13	1.10	0.61	13.62	27.53
1480.00	34.53	13.36	1.12	1.11	0.59	13.55	27.62
1485.00	34.50	12.16	1.12	1.12	0.61	13.57	27.54
1490.00	34.48	13.79	1.11	1.13	0.57	13.48	27.62
1495.00	34.45	13.51	1.11	1.13	0.61	13.61	27.55
1500.00	34.43	14.35	1.11	1.14	0.60	13.60	27.54
1510.00	34.38	14.05	1.10	1.16	0.59	13.58	27.67
1520.00	34.33	13.11	1.09	1.17	0.57	13.57	27.69

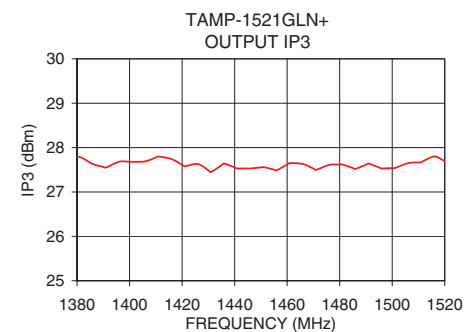
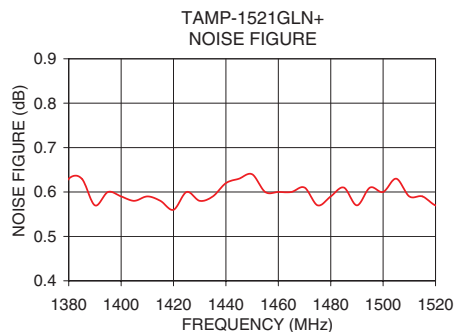
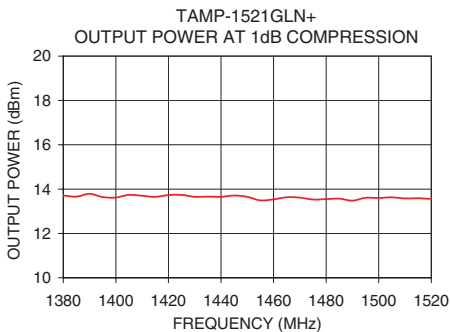
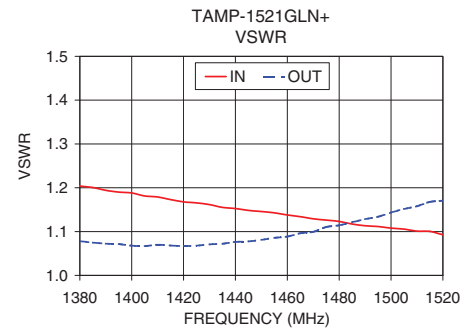
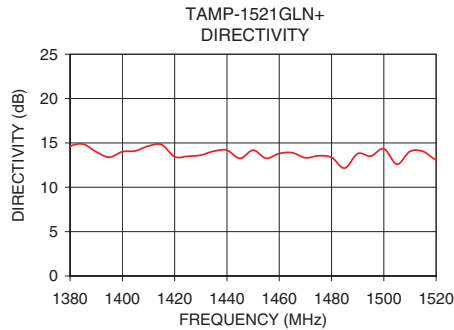
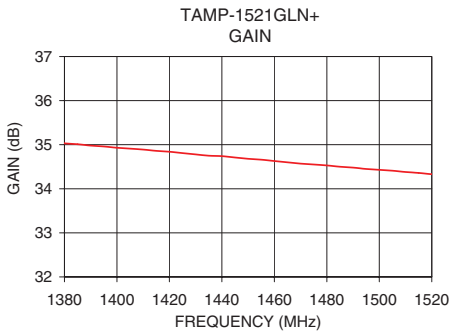

For detailed performance specs & shopping online see web site

P.O. Box 350166, Brooklyn, New York 11235-0003 (718) 934-4500 Fax (718) 332-4661 The Design Engineers Search Engine Provides ACTUAL Data Instantly at minicircuits.com

IF/RF MICROWAVE COMPONENTS

Notes: 1. Performance and quality attributes and conditions not expressly stated in this specification sheet are intended to be excluded and do not form a part of this specification sheet. 2. Electrical specifications and performance data contained herein are based on Mini-Circuit's applicable established test performance criteria and measurement instructions. 3. The parts covered by this specification sheet are subject to Mini-Circuits standard limited warranty and terms and conditions (collectively, "Standard Terms"); Purchasers of this part are entitled to the rights and benefits contained therein. For a full statement of the Standard Terms and the exclusive rights and remedies thereunder, please visit Mini-Circuits' website at www.minicircuits.com/MCLStore/terms.jsp.