

Ultra Low Noise MMIC Amplifier

PSA-5454+

50Ω 0.05 to 4 GHz

The Big Deal

- Ultra Low Noise Figure, 0.8 dB
- High IP3/Low Current, 20mA at +5V
- Wideband, up to 4 GHz



CASE STYLE: CA1389

Product Overview

Mini-Circuits PSA-5454+ is a E-PHEMT based Ultra-Low Noise MMIC Amplifier operating from 50 MHz to 4 GHz with a unique combination of low noise and high IP3 making this amplifier ideal for sensitive receiver applications. This design operates on a single 5V supply at only 20mA and is internally matched to 50 ohms.

Key Features

Feature	Advantages
Ultra Low Noise, 0.8 dB	Outstanding Noise Figure, measured in a 50 Ohm environment without any external matching
High IP3, 25 dBm	Combining Low Noise and High IP3 makes this MMIC amplifier ideal for Low Noise Receiver Front End (RFE) because it gives the user advantages at both ends of the dynamic range: sensitivity & two-tone spur-free dynamic range
Low Current, 20 mA	At only 20mA, the PSA-5454+ is ideal for remote applications with limited available power or densely packed applications where thermal management is critical.
Broad Band	Operating over a broadband the PSA-5454+ covers the primary wireless communications bands: Cellular, PCS, LTE, WiMAX
Internally Matched	No external matching elements required to achieve the advertised noise and output power over the full band
SOT-363 Package	Small size, industry standard package
Max Input Power, +15dBm	Ruggedized design operates up to input powers of +15dBm without the need of an external limiter
High Reliability	Low, small signal operating current of 30 mA nominal maintains junction temperatures typically below 105°C at 85°C ground lead temperature

Notes

- A. Performance and quality attributes and conditions not expressly stated in this specification document are intended to be excluded and do not form a part of this specification document.
B. Electrical specifications and performance data contained in this specification document are based on Mini-Circuit's applicable established test performance criteria and measurement instructions.
C. The parts covered by this specification document are subject to Mini-Circuits standard limited warranty and terms and conditions (collectively, "Standard Terms"); Purchasers of this part are entitled to the rights and benefits contained therein. For a full statement of the Standard Terms and the exclusive rights and remedies thereunder, please visit Mini-Circuits' website at www.minicircuits.com/MCLStore/terms.jsp



Low Noise, High IP3

Monolithic Amplifier

0.05-4 GHz

Product Features

- Single Positive Supply Voltage, +5V, Id=20mA
- Ultra Low Noise Figure, 0.8 dB typ. at 1GHz
- High IP3, 25 dBm typ. 1GHz
- Gain, 18dB typ. at 1GHz
- Output Power, up to +14 dBm typ.
- Micro-miniature size SOT-363 package
- Aqueous washable

Typical Applications

- Cellular
- ISM
- GSM
- WCDMA
- LTE
- WiMAX
- WLAN
- UNII and HIPERLAN



PSA-5454+

CASE STYLE: CA1389
PRICE: \$1.45 ea. QTY. (50)

+RoHS Compliant

The +Suffix identifies RoHS Compliance. See our web site for RoHS Compliance methodologies and qualifications

General Description

PSA-5454+ is an advanced wide band, high dynamic range, low noise, high IP3, high output power, monolithic amplifier. Manufactured using E-PHEMT* technology enables it to work with a single positive supply voltage.

simplified schematic and pin description

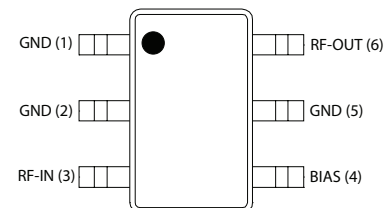
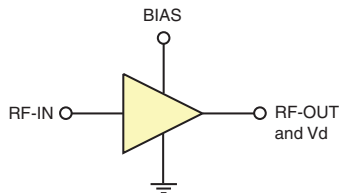

Function	Pin Number	Description (See Application Circuit, Fig. 3)
RF IN	3	RF input pin (connect to RF-IN via blocking cap C1 and Pin 4 via L2)
RF-OUT & Vd	6	RF output pin (connected to RF-out via blocking cap C2 and supply voltage Vd via RF Choke L1)
BIAS	4	Connected to Vs via Rbias. (Connect to ground via C4 & R1)
GND	1,2,5	Connections to ground

* Enhancement mode pseudomorphic High Electron Mobility Transistor.

Notes

- Performance and quality attributes and conditions not expressly stated in this specification document are intended to be excluded and do not form a part of this specification document.
- Electrical specifications and performance data contained in this specification document are based on Mini-Circuit's applicable established test performance criteria and measurement instructions.
- The parts covered by this specification document are subject to Mini-Circuits standard limited warranty and terms and conditions (collectively, "Standard Terms"); Purchasers of this part are entitled to the rights and benefits contained therein. For a full statement of the Standard Terms and the exclusive rights and remedies thereunder, please visit Mini-Circuits' website at www.minicircuits.com/MCLStore/terms.jsp



Electrical Specifications⁽¹⁾ at 25°C, Zo=50Ω, (refer to characterization circuit, Fig. 1)

Parameter	Condition (GHz)	Min.	Typ.	Max.	Units
Frequency Range		0.05		4.0	GHz
DC Voltage (V _d)			5.0		V
DC Current (I _d)		12	20	40	mA
DC Current (I _{Rbias})			0.6		mA
Noise Figure	0.05		2.6	1.3	dB
	0.5		0.8		
	1.0		0.8		
	2.0		1.1		
	3.0		1.4		
	4.0		1.7		
Gain	0.05	12.2	21.1	14.9	dB
	0.5		21.6		
	1.0		18.3		
	2.0		13.6		
	3.0		10.9		
	4.0		9.3		
Input Return Loss	0.05-0.5		8.0		dB
	0.5-4.0		6.0		
Output Return Loss	0.05-0.5		7.0		dB
	0.5-4.0		15.0		
Output IP3	0.05		21.2		dBm
	0.5		24.7		
	1.0		25.3		
	2.0		26.3		
	3.0		26.2		
	4.0		26.0		
Output Power @ 1 dB compression (P1dB) ⁽²⁾	0.05		6.6		dBm
	0.5		14.6		
	1.0		15.0		
	2.0		14.0		
	3.0		14.0		
	4.0		14.5		
DC Current Variation vs. Temperature ⁽³⁾			-0.08		mA/°C
Thermal Resistance			165		°C/W

Absolute Maximum Ratings⁽⁴⁾

Parameter	Ratings
Operating Temperature ⁽⁵⁾	-40°C to 85°C
Storage Temperature	-65°C to 150°C
Channel Temperature	150°C
DC Voltage (Pin 6)	6V
Power Dissipation	390mW
DC Current (Pin 6)	60mA
Bias Current (Pin 4)	10mA
Input Power (CW)	15dBm

- ⁽¹⁾ Measured on Mini-Circuits Characterization test board TB-533+ See Characterization Test Circuit (Fig. 1)
- ⁽²⁾ Specified with external current limiting of 30 mA. Capable of higher P1dB at higher currents (see Fig. 2)
- ⁽³⁾ Current at 85°C - Current at -45°C)/130
- ⁽⁴⁾ Permanent damage may occur if any of these limits are exceeded. These maximum ratings are not intended for continuous normal operation.
- ⁽⁵⁾ Defined with reference to ground pad temperature.

Notes

- A. Performance and quality attributes and conditions not expressly stated in this specification document are intended to be excluded and do not form a part of this specification document.
- B. Electrical specifications and performance data contained in this specification document are based on Mini-Circuit's applicable established test performance criteria and measurement instructions.
- C. The parts covered by this specification document are subject to Mini-Circuits standard limited warranty and terms and conditions (collectively, "Standard Terms"); Purchasers of this part are entitled to the rights and benefits contained therein. For a full statement of the Standard Terms and the exclusive rights and remedies thereunder, please visit Mini-Circuits' website at www.minicircuits.com/MCLStore/terms.jsp



Characterization Test Circuit

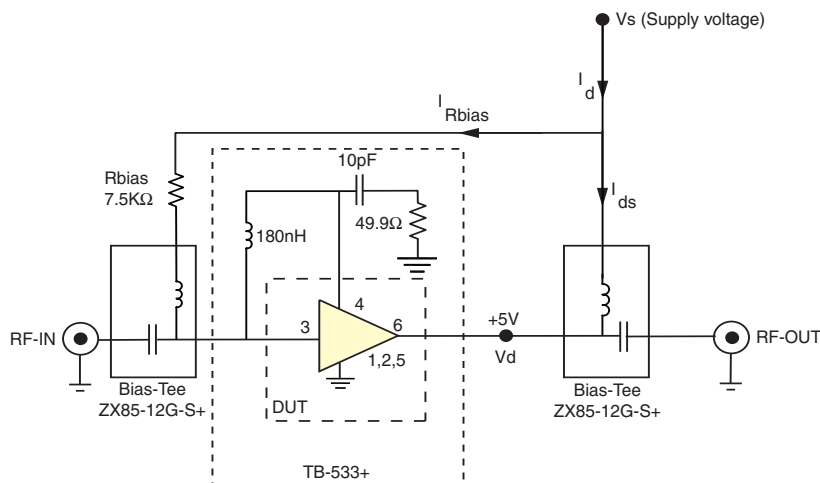

Fig 1. Block Diagram of Test Circuit used for characterization. (DUT soldered on Mini-Circuits Characterization Test Board TB-533+) Gain, Output power at 1dB compression (P1 dB), output IP3 (OIP3) and Noise Figure measured using Agilent's N5242A PNA-X microwave network analyzer.

Conditions:

1. Gain: Pin= -25dBm
2. Output IP3 (OIP3): Two tones, spaced 1 MHz apart, 0 dBm/tone at output.
3. Vs adjusted for 5V at device (Vd), compensating loss of bias tee.

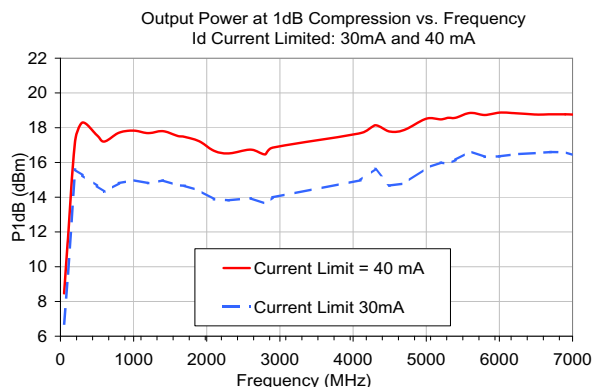
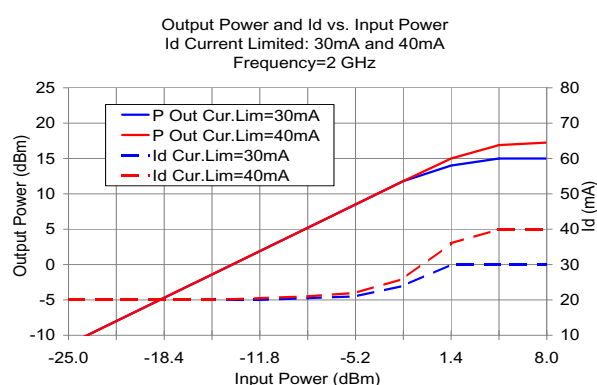

Fig 2. Output Power and Id vs. Input Power and Frequency.

Performance measured on Mini-Circuits Characterization test board TB-533+. See Characterization Test Circuit (Fig. 1) Measurements performed with current (Id) limited as noted.

Notes

- A. Performance and quality attributes and conditions not expressly stated in this specification document are intended to be excluded and do not form a part of this specification document.
- B. Electrical specifications and performance data contained in this specification document are based on Mini-Circuit's applicable established test performance criteria and measurement instructions.
- C. The parts covered by this specification document are subject to Mini-Circuits standard limited warranty and terms and conditions (collectively, "Standard Terms"); Purchasers of this part are entitled to the rights and benefits contained therein. For a full statement of the Standard Terms and the exclusive rights and remedies thereunder, please visit Mini-Circuits' website at www.minicircuits.com/MCLStore/terms.jsp

Recommended Application Circuit

(refer to evaluation board for PCB Layout and component values)

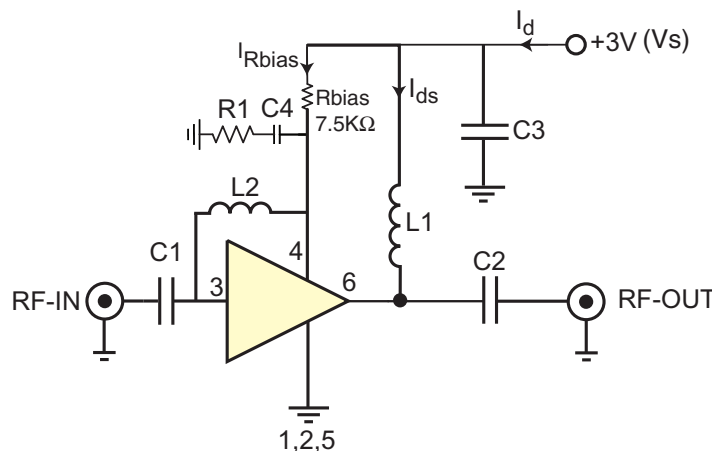

Fig 3. Recommended Application Circuit
 Note: Resistance of L1, 0.1-0.2Ω typically

Typical Current (I_d) as a function of R_{bias}
 ($V_s = 5V$)

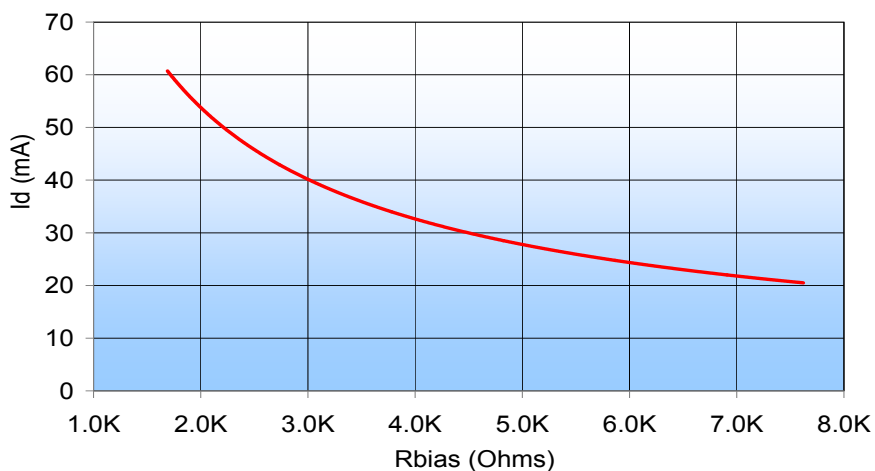
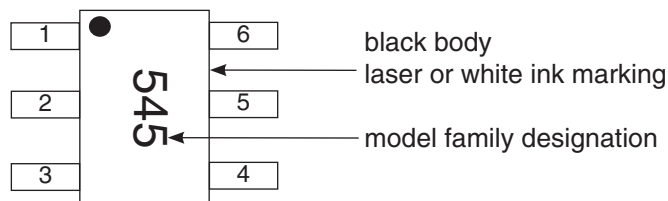

Fig 4. I_d varies as a function of R_{bias} . The I_d current range is defined based upon the specific R_{bias} value noted in the Application Circuit (Fig 3). R_{bias} may be adjusted to optimize I_d for a customers' application. RF performance will vary accordingly.

Notes

- A. Performance and quality attributes and conditions not expressly stated in this specification document are intended to be excluded and do not form a part of this specification document.
- B. Electrical specifications and performance data contained in this specification document are based on Mini-Circuit's applicable established test performance criteria and measurement instructions.
- C. The parts covered by this specification document are subject to Mini-Circuits standard limited warranty and terms and conditions (collectively, "Standard Terms"); Purchasers of this part are entitled to the rights and benefits contained therein. For a full statement of the Standard Terms and the exclusive rights and remedies thereunder, please visit Mini-Circuits' website at www.minicircuits.com/MCLStore/terms.jsp

Product Marking



Additional Detailed Technical Information

Additional information is available on our web site www.minicircuits.com. To access this information enter the model number on our web site home page.

Performance data, graphs, s-parameter data set (.zip file)

Case Style: CA1389

Plastic molded SOT-363 package, lead finish: matte tin

Tape & Reel: F101

Standard quantities available on reel: 7" reels with 20, 50, 100, 200, 500, 1K, or 2K devices.

Suggested Layout for PCB Design: PL-311

Evaluation Board: TB-534-4+

Environmental Ratings: ENV08T2

ESD Rating

Human Body Model (HBM): Class 1A (250 to <500V) in accordance with ANSI/ESD STM 5.1 - 2001

Machine Model (MM): Class M1 (<100V) in accordance with ANSI/ESD STM5.2-1999; passes 40V

MSL Rating

Moisture Sensitivity: MSL1 in accordance with IPC/JEDEC J-STD-020D

MSL Test Flow Chart

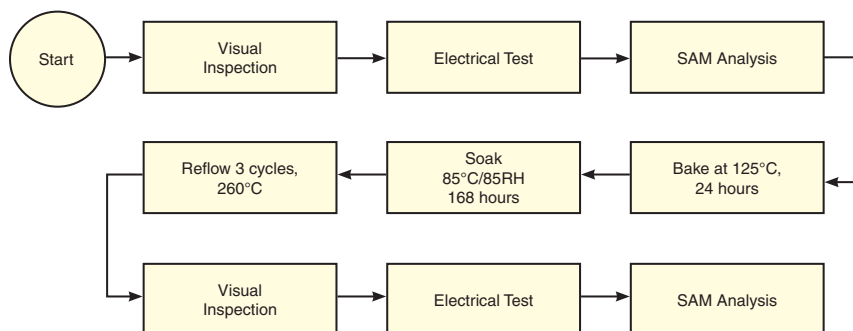

Notes

- A. Performance and quality attributes and conditions not expressly stated in this specification document are intended to be excluded and do not form a part of this specification document.
- B. Electrical specifications and performance data contained in this specification document are based on Mini-Circuit's applicable established test performance criteria and measurement instructions.
- C. The parts covered by this specification document are subject to Mini-Circuits standard limited warranty and terms and conditions (collectively, "Standard Terms"); Purchasers of this part are entitled to the rights and benefits contained therein. For a full statement of the Standard Terms and the exclusive rights and remedies thereunder, please visit Mini-Circuits' website at www.minicircuits.com/MCLStore/terms.jsp