

# Ultra Low Noise MMIC Amplifier

PSA-545+

50Ω      0.05 to 4 GHz

## The Big Deal

- Ultra Low Noise Figure, 0.8 dB
- High IP3
- Wideband, up to 4 GHz



CASE STYLE: CA1389

[LTE Performance](#)

## Product Overview

Mini-Circuits PSA-545+ is a E-PHEMT based Ultra-Low Noise MMIC Amplifier operating from 50 MHz to 4 GHz with a unique combination of low noise and high IP3 making this amplifier ideal for sensitive receiver applications. This design operates on a single 3V supply at only 80mA and is internally matched to 50 ohms.

## Key Features

Feature	Advantages
Ultra Low Noise, 0.8 dB	Outstanding Noise Figure, measured in a 50 Ohm environment without any external matching
High IP3, 36 dBm	Combining Low Noise and High IP3 makes this MMIC amplifier ideal for Low Noise Receiver Front End (RFE) because it gives the user advantages at both ends of the dynamic range: sensitivity & two-tone spur-free dynamic range
High Output Power, +20 dBm	The PSA-545+ provides up to +20dBm output power at 1dB compression enabling this amplifier to support high linear dynamic range requirements.-
Broad Band	Operating over a broadband the PSA-545+ covers the primary wireless communications bands: Cellular, PCS, LTE, WiMAX
Internally Matched	No external matching elements required to achieve the advertised noise and output power over the full band
SOT-363 Package	Small size, industry standard package
Max Input Power, +15dBm	Ruggedized design operates up to input powers of +15dBm without the need of an external limiter
High Reliability	Low, small signal operating current of 80mA nominal maintains junction temperatures typically below 125°C at 85°C ground lead temperature



P.O. Box 350166, Brooklyn, New York 11235-0003 (718) 934-4500 Fax (718) 332-4661 *The Design Engineers Search Engine* Provides ACTUAL Data Instantly at [minicircuits.com](http://minicircuits.com)

For detailed performance specs & shopping online see web site

IF/RF MICROWAVE COMPONENTS

**Notes:** 1. Performance and quality attributes and conditions not expressly stated in this specification sheet are intended to be excluded and do not form a part of this specification sheet. 2. Electrical specifications and performance data contained herein are based on Mini-Circuit's applicable established test performance criteria and measurement instructions. 3. The parts covered by this specification sheet are subject to Mini-Circuits standard limited warranty and terms and conditions (collectively, "Standard Terms"); Purchasers of this part are entitled to the rights and benefits contained therein. For a full statement of the Standard Terms and the exclusive rights and remedies thereunder, please visit Mini-Circuits' website at [www.minicircuits.com/MCLStore/terms.jsp](http://www.minicircuits.com/MCLStore/terms.jsp).

Low Noise, High IP3

# Monolithic Amplifier

0.05-4 GHz

## Product Features

- Single Positive Supply Voltage, +3V, Id=80mA
- Ultra Low Noise Figure, 0.8 dB typ. at 1 GHz
- High IP3, up to 35 dBm typ. at 1 GHz
- Output Power at 1dB comp., up to +20 dBm typ.
- Gain, 20 dB typ. at 1GHz
- Micro-miniature size SOT-363 package
- Aqueous washable

## Typical Applications

- Cellular
- ISM
- GSM
- WCDMA
- LTE
- WiMax
- WLAN
- UNII and HIPERLAN



## PSA-545+

CASE STYLE: CA1389  
PRICE: \$1.45 ea. QTY. (50)

### +RoHS Compliant

The +Suffix identifies RoHS Compliance. See our web site for RoHS Compliance methodologies and qualifications

LTE Performance

## General Description

PSA-545+ is an advanced wide band, high dynamic range, low noise, high IP3, high output power, monolithic amplifier. Manufactured using E-PHEMT\* technology enables it to work with a single positive supply voltage.

### simplified schematic and pin description

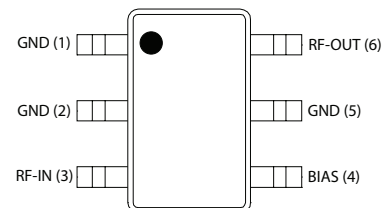
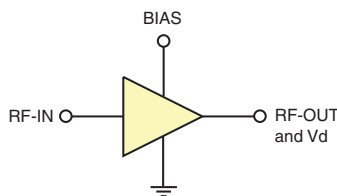

Function	Pin Number	Description (See Application Circuit, Fig. 2)
RF IN	3	RF input pin (connect to pin 4 via L2)
RF-OUT & Vd	6	RF output pin (connected to RF-out via blocking cap C2 and supply voltage Vd via RF Choke L1)
BIAS	4	Connected to Vs via Rbias. (Connect to ground via C4 & R1)
GND	1,2,5	Connections to ground

\* Enhancement mode pseudomorphic High Electron Mobility Transistor.

#### Notes

- A. Performance and quality attributes and conditions not expressly stated in this specification document are intended to be excluded and do not form a part of this specification document.  
B. Electrical specifications and performance data contained in this specification document are based on Mini-Circuit's applicable established test performance criteria and measurement instructions.  
C. The parts covered by this specification document are subject to Mini-Circuits standard limited warranty and terms and conditions (collectively, "Standard Terms"); Purchasers of this part are entitled to the rights and benefits contained therein. For a full statement of the Standard Terms and the exclusive rights and remedies thereunder, please visit Mini-Circuits' website at [www.minicircuits.com/MCLStore/terms.jsp](http://www.minicircuits.com/MCLStore/terms.jsp)



**Electrical Specifications<sup>(1)</sup> at 25°C, Zo=50Ω,** (refer to characterization circuit, Fig. 1)

Parameter	Condition (GHz)	Min.	Typ.	Max.	Units
Frequency Range		0.05		4.0	GHz
at DC Volts (Vd)			3.0		V
DC Current (Id)		60	80	100	mA
Bias Current (I <sub>Rbias</sub> )			5.6		mA
Noise Figure	0.05		2.1	1.3	dB
	0.5		0.7		
	1.0		0.8		
	2.0		1.0		
	3.0		1.3		
	4.0		1.7		
Gain	0.05	17.8	24.8	21.8	dB
	0.5		23.5		
	1.0		19.8		
	2.0		14.9		
	3.0		12.1		
	4.0		10.4		
Input Return Loss	0.05-0.5		8		dB
	0.5-4.0		6		
Output Return Loss	0.05-0.2		12		dB
	0.2-4.0		18		
Output IP3	0.05		34.4		dBm
	0.5		34.9		
	1.0		35.4		
	2.0		36.2		
	3.0		36.3		
	4.0		35.4		
Output Power @ 1dB compression <sup>(2)</sup>	0.05		19.6		dBm
	0.5		19.6		
	1.0		19.5		
	2.0		20.2		
	3.0		20.5		
	4.0		20.5		
DC Current Variation Vs. Temperature <sup>(3)</sup>			-0.064		mA/°C
Thermal Resistance <sup>(5)</sup>			165		°C/W

**Absolute Maximum Ratings<sup>(4)</sup>**

Parameter	Ratings
Operating Temperature <sup>(5)</sup>	-40°C to 85°C
Storage Temperature	-65°C to 150°C
Channel Temperature	150°C
DC Voltage (Pin 6)	5V
Device Current (Pin 6)	130 mA
Power Dissipation	390 mW
Bias Reference Current (Pin 4)	10 mA
Input Power (CW) (Pin 3)	15 dBm

<sup>(1)</sup> Measured on Mini-Circuits Characterization test board TB-533+.

See Characterization Test Circuit (Fig. 1)

<sup>(2)</sup> Current increases at P1dB

<sup>(3)</sup> (Current at 85°C - Current at -45°C)/130

<sup>(4)</sup> Permanent damage may occur if any of these limits are exceeded.

These maximum ratings are not intended for continuous normal operation.

<sup>(5)</sup> Defined with reference to ground pad temperature.

**Notes**

A. Performance and quality attributes and conditions not expressly stated in this specification document are intended to be excluded and do not form a part of this specification document.  
 B. Electrical specifications and performance data contained in this specification document are based on Mini-Circuit's applicable established test performance criteria and measurement instructions.  
 C. The parts covered by this specification document are subject to Mini-Circuits standard limited warranty and terms and conditions (collectively, "Standard Terms"); Purchasers of this part are entitled to the rights and benefits contained therein. For a full statement of the Standard Terms and the exclusive rights and remedies thereunder, please visit Mini-Circuits' website at [www.minicircuits.com/MCLStore/terms.jsp](http://www.minicircuits.com/MCLStore/terms.jsp)

Characterization Test Circuit

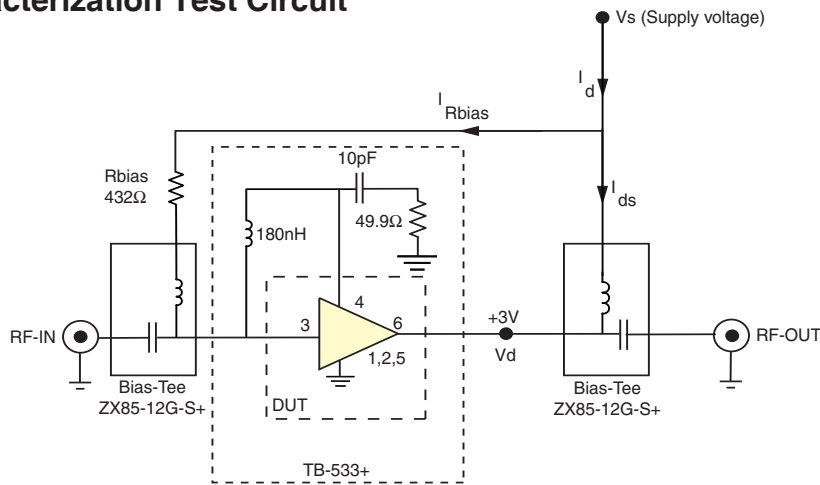

**Fig 1.** Block Diagram of Test Circuit used for characterization. (DUT soldered on Mini-Circuits Characterization Test Board TB-533+) Gain, Return loss, Output power at 1dB compression (P1 dB), Output IP3 (OIP3) and Noise Figure measured using Agilent's N5242A PNA-X microwave network analyzer.

**Conditions:**

1. Gain: Pin= -25dBm
2. Output IP3 (OIP3): Two tones, spaced 1 MHz apart, 5 dBm/tone at output.

**Recommended Application Circuit**

(refer to evaluation board for PCB Layout and component values)

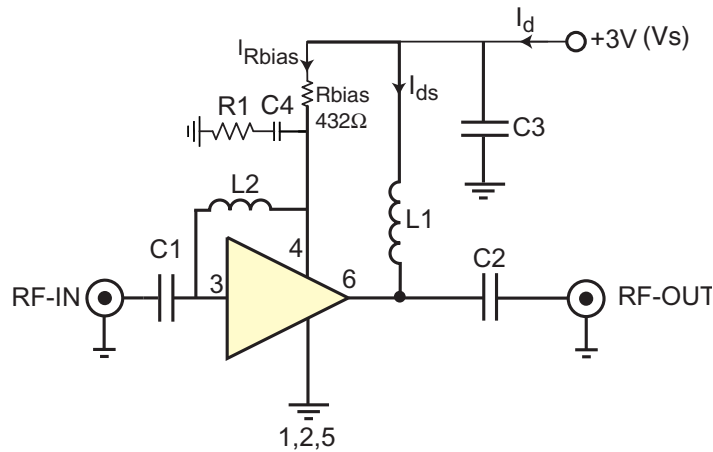

**Fig 2. Recommended Application Circuit**

Note: Resistance of L1, 0.1-0.2Ω typically

**Notes**

- A. Performance and quality attributes and conditions not expressly stated in this specification document are intended to be excluded and do not form a part of this specification document.
- B. Electrical specifications and performance data contained in this specification document are based on Mini-Circuit's applicable established test performance criteria and measurement instructions.
- C. The parts covered by this specification document are subject to Mini-Circuits standard limited warranty and terms and conditions (collectively, "Standard Terms"); Purchasers of this part are entitled to the rights and benefits contained therein. For a full statement of the Standard Terms and the exclusive rights and remedies thereunder, please visit Mini-Circuits' website at [www.minicircuits.com/MCLStore/terms.jsp](http://www.minicircuits.com/MCLStore/terms.jsp)

**Product Marking**

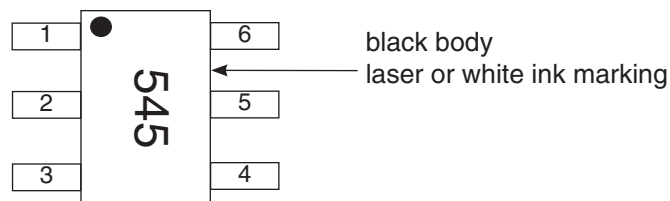

**Additional Detailed Technical Information**

Additional information is available on our web site [www.minicircuits.com](http://www.minicircuits.com). To access this information enter the model number on our web site home page.

**Performance data, graphs, s-parameter data set (.zip file)**

**Case Style: CA1389**

Plastic molded SOT-363 package, lead finish: matte tin

**Tape & Reel: F101**

Standard quantities available on reel: 7" reels with 20, 50, 100, 200, 500, 1K, or 2K devices.

**Suggested Layout for PCB Design: PL-311**

**Evaluation Board: TB-534+**

**Environmental Ratings: ENV08T2**

**ESD Rating**

Human Body Model (HBM): Class 1A (250 to <500V) in accordance with ANSI/ESD STM 5.1 - 2001

Machine Model (MM): Class M1 (<100V) in accordance with ANSI/ESD STM5.2-1999; passes 40V

**MSL Rating**

Moisture Sensitivity: MSL1 in accordance with IPC/JEDEC J-STD-020D

**MSL Test Flow Chart**

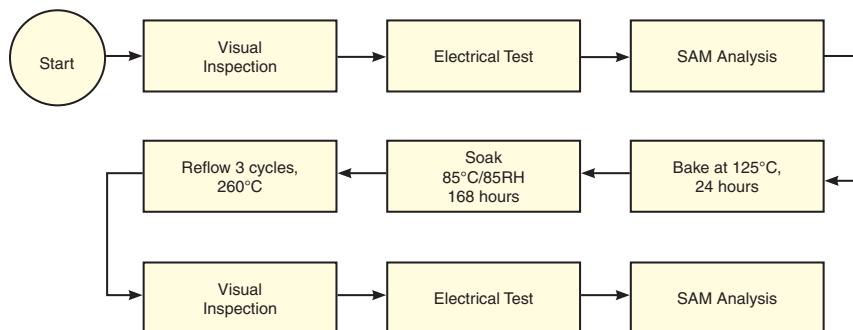

**Notes**

- A. Performance and quality attributes and conditions not expressly stated in this specification document are intended to be excluded and do not form a part of this specification document.
- B. Electrical specifications and performance data contained in this specification document are based on Mini-Circuit's applicable established test performance criteria and measurement instructions.
- C. The parts covered by this specification document are subject to Mini-Circuits standard limited warranty and terms and conditions (collectively, "Standard Terms"); Purchasers of this part are entitled to the rights and benefits contained therein. For a full statement of the Standard Terms and the exclusive rights and remedies thereunder, please visit Mini-Circuits' website at [www.minicircuits.com/MCLStore/terms.jsp](http://www.minicircuits.com/MCLStore/terms.jsp)