

Ultra Low Noise MMIC Amplifier

PMA-5455+

50Ω 0.05 to 6 GHz



3mm x 3mm MCLP (EIA: QFN) Pkg

The Big Deal

- Ultra Low Noise Figure, 0.8 dB
- High IP3/Low Current, 40mA
- Wideband, up to 6 GHz

Product Overview

Mini-Circuits PMA-5455+ is a E-PHEMT based Ultra-Low Noise MMIC Amplifier operating from 50 MHz to 6 GHz with a unique combination of low noise and high IP3 making this amplifier ideal for sensitive receiver applications. This design operates on a single 5V supply at only 40 mA and is internally matched to 50 Ohms.

Key Features

Feature	Advantages
Ultra Low Noise, 0.8 dB	Outstanding Noise Figure, measured in a 50 Ohm environment without any external matching
High IP3, 31 dBm	Combining Low Noise and High IP3 makes this MMIC amplifier ideal for Low Noise Receiver Front End (RFE) because it gives the user advantages at both ends of the dynamic range: sensitivity & two-tone spur-free dynamic range
Low Current, 40 mA	At only 40mA, the PMA-5455+ is ideal for remote applications with limited available power or densely packed applications where thermal management is critical.
Broad Band	Operating over a broadband the PMA-5455+ covers the primary wireless communications bands: Cellular, PCS, LTE, WiMAX
Internally Matched	No external matching elements required to achieve the advertised noise and output power over the full band
MCLP Package	Low Inductance, repeatable transitions, excellent thermal pad
Max Input Power, +20 dBm	Ruggedized design operates up to input powers of +20 dBm without the need of an external limiter
High Reliability	Low, small signal operating current of 40mA nominal maintains junction temperatures typically below 110°C at 85°C ground lead temperature

Notes

- A. Performance and quality attributes and conditions not expressly stated in this specification document are intended to be excluded and do not form a part of this specification document.
B. Electrical specifications and performance data contained in this specification document are based on Mini-Circuit's applicable established test performance criteria and measurement instructions.
C. The parts covered by this specification document are subject to Mini-Circuits standard limited warranty and terms and conditions (collectively, "Standard Terms"); Purchasers of this part are entitled to the rights and benefits contained therein. For a full statement of the Standard Terms and the exclusive rights and remedies thereunder, please visit Mini-Circuits' website at www.minicircuits.com/MCLStore/terms.jsp

Low Noise, High IP3

Monolithic Amplifier

0.05-6 GHz

Product Features

- Single Positive Supply Voltage, 5V, $I_d=40\text{mA}$
- Ultra Low Noise Figure, 0.8 dB typ. at 1GHz
- High IP3, 31 dBm typ. 1GHz
- Gain, 19 dB typ. at 1 GHz
- Output Power, up to +19.5 dBm typ.
- Micro-miniature size - 3mm x 3mm
- Aqueous washable

Typical Applications

- Cellular
- ISM
- GSM
- WCDMA
- LTE
- WiMAX
- WLAN
- UNII and HIPERLAN



PMA-5455+

CASE STYLE: DQ849
PRICE: \$1.49 ea. QTY. (20)

+RoHS Compliant

The +Suffix identifies RoHS Compliance. See our web site for RoHS Compliance methodologies and qualifications

General Description

PMA-5455+ is a high dynamic range, low noise, high IP3, high output power, monolithic amplifier. Manufactured using E-PHEMT* technology enables it to work with a single positive supply voltage. Unconditionally stable over the operating frequency.

simplified schematic and pad description

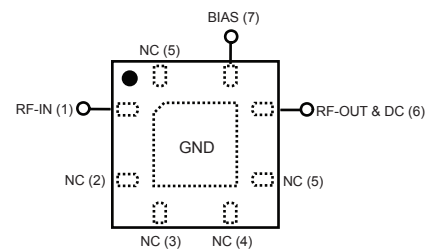
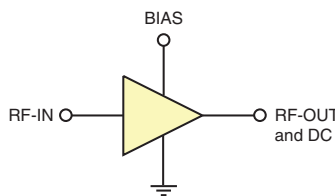

Function	Pad Number	Description (See Application Circuit, Fig. 3)
RF-IN	1	RF input pad
RF-OUT & DC	6	RF output pad (connected to RF-OUT via blocking external cap C2, and Supply voltage V_s via RF Choke L1)
BIAS	7	Bias pad (connected to V_s via Rbias)
GND	paddle in center of bottom	Connected to ground
NOT USED	2,3,4,5,8	No internal connection; recommended use: per PCB Layout PL-299

*Enhancement mode Pseudomorphic High Electron Mobility Transistor.

Notes

- Performance and quality attributes and conditions not expressly stated in this specification document are intended to be excluded and do not form a part of this specification document.
- Electrical specifications and performance data contained in this specification document are based on Mini-Circuit's applicable established test performance criteria and measurement instructions.
- The parts covered by this specification document are subject to Mini-Circuits standard limited warranty and terms and conditions (collectively, "Standard Terms"); Purchasers of this part are entitled to the rights and benefits contained therein. For a full statement of the Standard Terms and the exclusive rights and remedies thereunder, please visit Mini-Circuits' website at www.minicircuits.com/MCLStore/terms.jsp



Electrical Specifications⁽¹⁾ at 25°C, Zo=50Ω (refer to characterization circuit, see Fig. 1)

Parameter	Condition (GHz)	Min.	Typ.	Max.	Units
Frequency Range		0.05		6.0	GHz
DC Voltage (V _d)			5.0		V
DC Current (I _d)		30	40	60	mA
DC Current (I _{Rbias})			1.2		mA
Noise Figure	0.05		1.8	1.3	dB
	0.5		0.8		
	1.0		0.8		
	2.0		1.0		
	3.0		1.3		
	4.0		1.6		
	5.0		2.1		
6.0		2.4			
Gain	0.05	12.6	25.1	15.4	dB
	0.5		22.6		
	1.0		19.0		
	2.0		14.0		
	3.0		10.9		
	4.0		8.9		
	5.0		7.1		
6.0	5.6				
Input Return Loss	0.05-0.5		9.0		dB
	0.5-6		7.0		
Output Return Loss	0.05-0.3		15.0		dB
	0.3-6		20.0		
Output IP3	0.05		29.1		dBm
	0.5		30.0		
	1.0		31.0		
	2.0		32.7		
	3.0		33.3		
	4.0		32.9		
	5.0		33.8		
6.0		34.2			
Output Power @ 1 dB compression ⁽²⁾	0.05		18.8		dBm
	0.5		19.3		
	1.0		19.6		
	2.0		19.3		
	3.0		19.1		
	4.0		19.1		
	5.0		19.9		
6.0		19.8			
DC Current Variation vs. Temperature ⁽³⁾			-0.072		mA/°C
Thermal Resistance			128		°C/W

Absolute Maximum Ratings⁽⁴⁾

Parameter	Ratings
Operating Temperature ⁽⁵⁾	-40°C to 85°C
Storage Temperature	-55°C to 100°C
Channel Temperature	150°C
DC Voltage (Pad 6)	6V
Power Dissipation	500mW
DC Current (Pad 6)	100mA
Bias Current (Pad 7)	10mA
Input Power	20dBm

- ⁽¹⁾ Measured on Mini-Circuits Characterization test board TB-502+. See Characterization Test Circuit (Fig. 1)
- ⁽²⁾ P1dB specified with external current limiting of 50mA; Capable of higher P1dB at higher current (see Fig. 2)
- ⁽³⁾ (Current at 85°C - Current at -45°C)/130
- ⁽⁴⁾ Permanent damage may occur if any of these limits are exceeded. These maximum ratings are not intended for continuous normal operation.
- ⁽⁵⁾ Defined with reference to ground pad temperature.

Notes

- A. Performance and quality attributes and conditions not expressly stated in this specification document are intended to be excluded and do not form a part of this specification document.
- B. Electrical specifications and performance data contained in this specification document are based on Mini-Circuit's applicable established test performance criteria and measurement instructions.
- C. The parts covered by this specification document are subject to Mini-Circuits standard limited warranty and terms and conditions (collectively, "Standard Terms"); Purchasers of this part are entitled to the rights and benefits contained therein. For a full statement of the Standard Terms and the exclusive rights and remedies thereunder, please visit Mini-Circuits' website at www.minicircuits.com/MCLStore/terms.jsp

Characterization Test Circuit

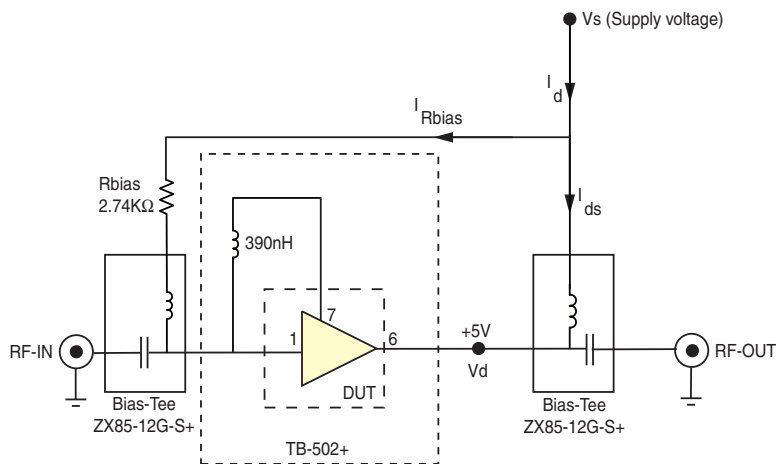

Fig 1. Block Diagram of Test Circuit used for characterization. (DUT soldered on Mini-Circuits Characterization Test Board TB-502+) Gain, Output power at 1dB compression (P1dB), Output IP3 (OIP3) and Noise Figure measured using Agilent's N5242A PNA-X Microwave network analyzer.

Conditions:

1. Gain: Pin=-25 dBm
2. Output IP3 (OIP3): Two tones, spaced 1 MHz apart, 5 dBm/tone at output.
3. Vs adjusted for 5V at device (Vd), compensating loss of bias tee.

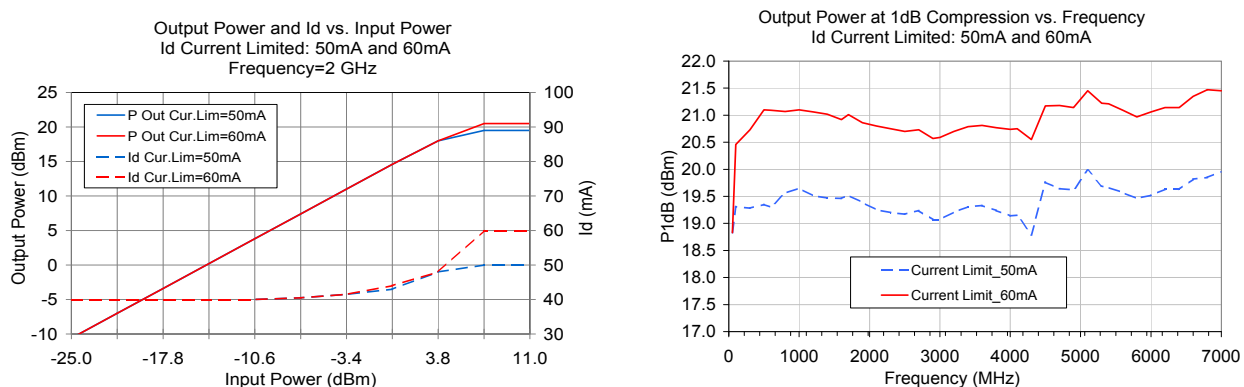

Fig 2. Output Power and Id vs. Input Power and Frequency. Performance measured on Mini-Circuits Characterization test board TB-502+. See Characterization Test Circuit (Fig. 1) Measurements performed with current (Id) limited as noted.

Notes

- A. Performance and quality attributes and conditions not expressly stated in this specification document are intended to be excluded and do not form a part of this specification document.
- B. Electrical specifications and performance data contained in this specification document are based on Mini-Circuit's applicable established test performance criteria and measurement instructions.
- C. The parts covered by this specification document are subject to Mini-Circuits standard limited warranty and terms and conditions (collectively, "Standard Terms"); Purchasers of this part are entitled to the rights and benefits contained therein. For a full statement of the Standard Terms and the exclusive rights and remedies thereunder, please visit Mini-Circuits' website at www.minicircuits.com/MCLStore/terms.jsp

Recommended Application Circuit

(refer to evaluation board for PCB Layout and component values)

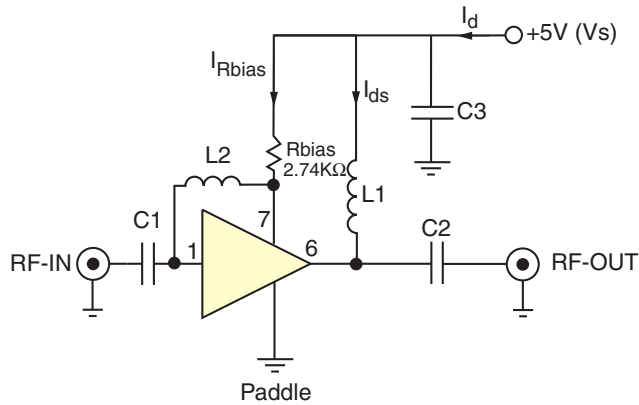

Fig 3. Recommended Application Circuit
 Note: Resistance of L1, 0.1-0.2Ω typically

Typical Current (I_d) as a function of R_{bias}
 ($V_d = 5V$)

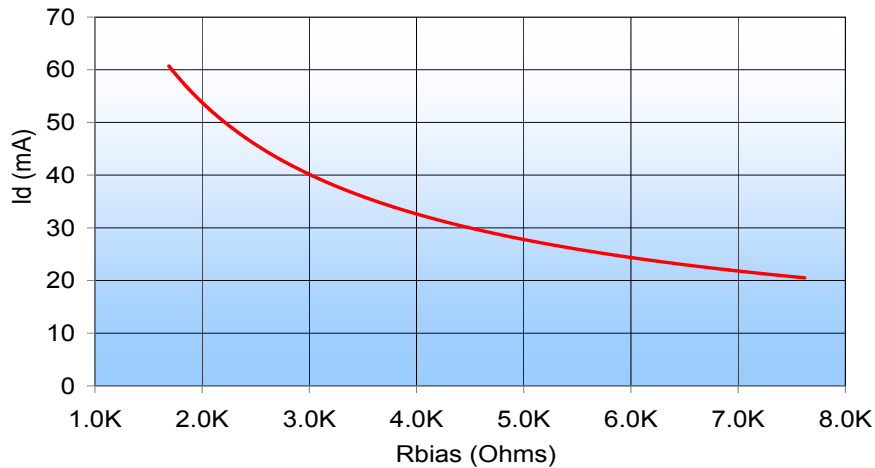
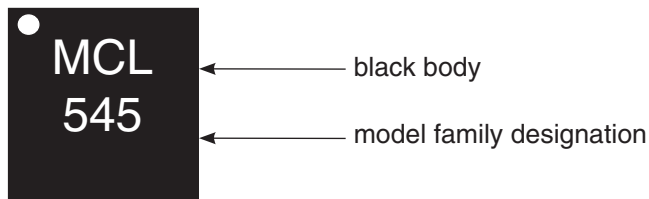

Fig 4. I_d varies as a function of R_{bias} . The I_d current range is defined based upon the specific R_{bias} value noted in the Application Circuit (Fig 3). R_{bias} may be adjusted to optimize I_d for a customers' application. RF performance will vary accordingly.

Notes

- A. Performance and quality attributes and conditions not expressly stated in this specification document are intended to be excluded and do not form a part of this specification document.
- B. Electrical specifications and performance data contained in this specification document are based on Mini-Circuit's applicable established test performance criteria and measurement instructions.
- C. The parts covered by this specification document are subject to Mini-Circuits standard limited warranty and terms and conditions (collectively, "Standard Terms"); Purchasers of this part are entitled to the rights and benefits contained therein. For a full statement of the Standard Terms and the exclusive rights and remedies thereunder, please visit Mini-Circuits' website at www.minicircuits.com/MCLStore/terms.jsp

Product Marking



Additional Detailed Technical Information

Additional information is available on our web site www.minicircuits.com. To access this information enter the model number on our web site home page.

Performance data, graphs, s-parameter data set (.zip file)

Case Style: DQ849

Plastic package, exposed paddle, lead finish: tin-silver over nickel

Tape & Reel: F104

Standard quantities available on reel: 7" reels with 20, 50, 100, 200, 500, 1K, or 2K devices

Suggested Layout for PCB Design: PL-299

Evaluation Board: TB-501-5+ (50-5000 MHz)

Environmental Ratings: ENV08T1

ESD Rating

Human Body Model (HBM): Class 1A (250V to <500V) in accordance with ANSI/ESD STM 5.1 - 2001

Machine Model (MM): Class M1 (<100V) in accordance with ANSI/ESD STM5.2-1999; passes 40V

MSL Rating

Moisture Sensitivity: MSL1 in accordance with IPC/JEDEC J-STD-020D

MSL Test Flow Chart

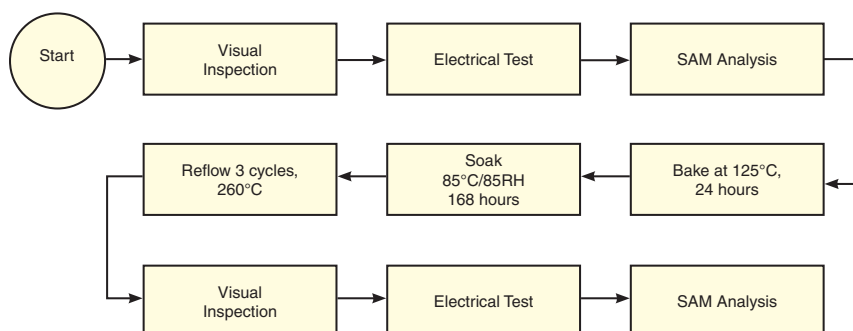

Notes

- A. Performance and quality attributes and conditions not expressly stated in this specification document are intended to be excluded and do not form a part of this specification document.
- B. Electrical specifications and performance data contained in this specification document are based on Mini-Circuit's applicable established test performance criteria and measurement instructions.
- C. The parts covered by this specification document are subject to Mini-Circuits standard limited warranty and terms and conditions (collectively, "Standard Terms"); Purchasers of this part are entitled to the rights and benefits contained therein. For a full statement of the Standard Terms and the exclusive rights and remedies thereunder, please visit Mini-Circuits' website at www.minicircuits.com/MCLStore/terms.jsp