

Address: Midas Sensors, Electra House, 32 Southtown Road, Great Yarmouth, Norfolk, NR31 0DU
Telephone: +44 (0)1493 602602
Fax: +44 (0)1493 665111
Email: sales@midassensors.com
Website: www.midassensors.com

Specification

MCUSR10P40B07RO/
MCUST10P40B07RO

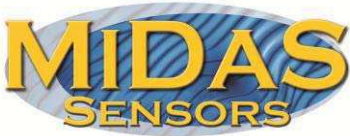



Address: Midas Sensors, Electra House, 32 Southtown Road, Great Yarmouth, Norfolk, NR31 0DU
Telephone: +44 (0)1493 602602
Fax: +44 (0)1493 665111
Email: sales@midassensors.com
Website: www.midassensors.com

Midas Ultrasonic Sensors Part Number System

MC US T 16 P 40 B 12 R S
1 2 3 4 5 6 7 8 9 10

- 1 = **MC:** Midas Components
- 2 = **US:** Ultrasonic Sensor **PV:** Piezo Vibration
- 3 = **T:** Transmitter **R:** Receiver **D:** Dual
- 4 = **Diameter** (e.g. 16 = 16mm)
- 5 = **P:** Plastic **A:** Aluminium
- 6 = **Frequency** (e.g. 40 = 40KHz)
- 7 = **B:** Black **S:** Silver
- 8 = **Height** (e.g. 12 = 12mm)
- 9 = **RoHS**
- 10 = **O:** Open **S:** Splash Proof





1.Applications

Burglar alarms、 Range finds、 Automatic doors、 Remote control.

2.Features

- 2.1)Open structure and fission
- 2.2) Compact and light weight.
- 2.3) High sensitivity and sound pressure.
- 2.4) Less power consumption.
- 2.5) High reliability

3.Technical terms

No.	Item	Specification	
1.	Type	MCUST10P40B07RO	MCUSR10P40B07RO
2.	Construction	Open Structure	
3.	Using Method	Transmitter	Receiver
4.	Center Frequency	40.1±1K Hz	38.3±1K Hz
5.	Sound Pressure Level(at 40KHZ) min.106dB (10V/30cm)	---	
6.	Sensitivity at 40.0KHz	---	min. -70dB V/μbar
7.	Capacitance	2500pF±25% at 1KHz	
8.	Directivity	50deg	
9.	Operating Tem.Range	-35 to +85℃	
10.	Storage Tem.Range	-35 to +85℃	
11.	Detectable Range	0.2...6m	
12.	Housing Material	MPPO	

4. Drawing

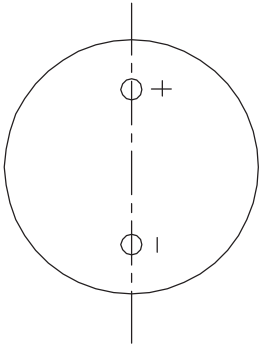
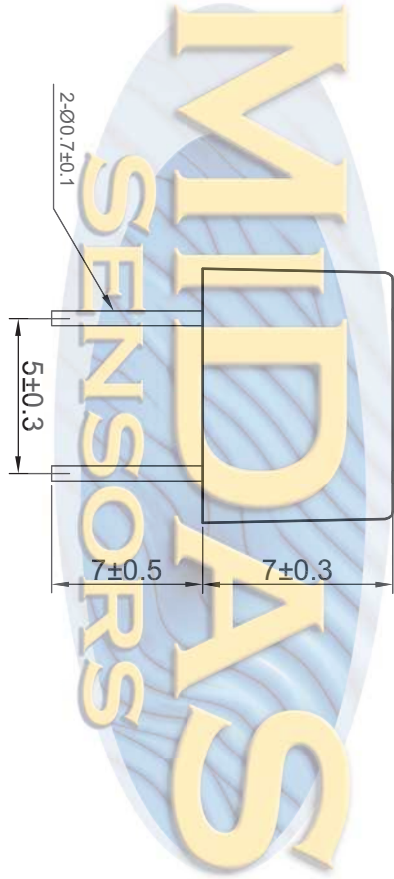
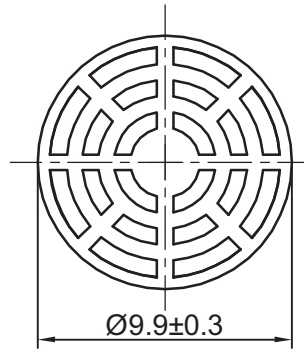

5. Beam Pattern

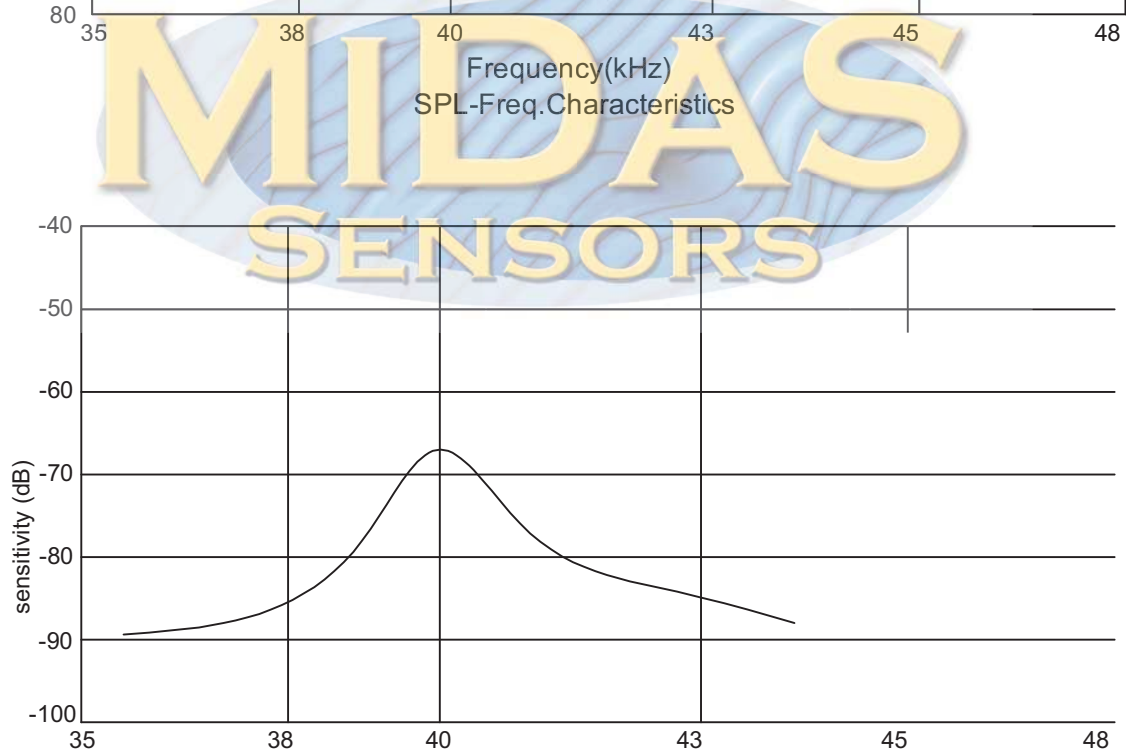
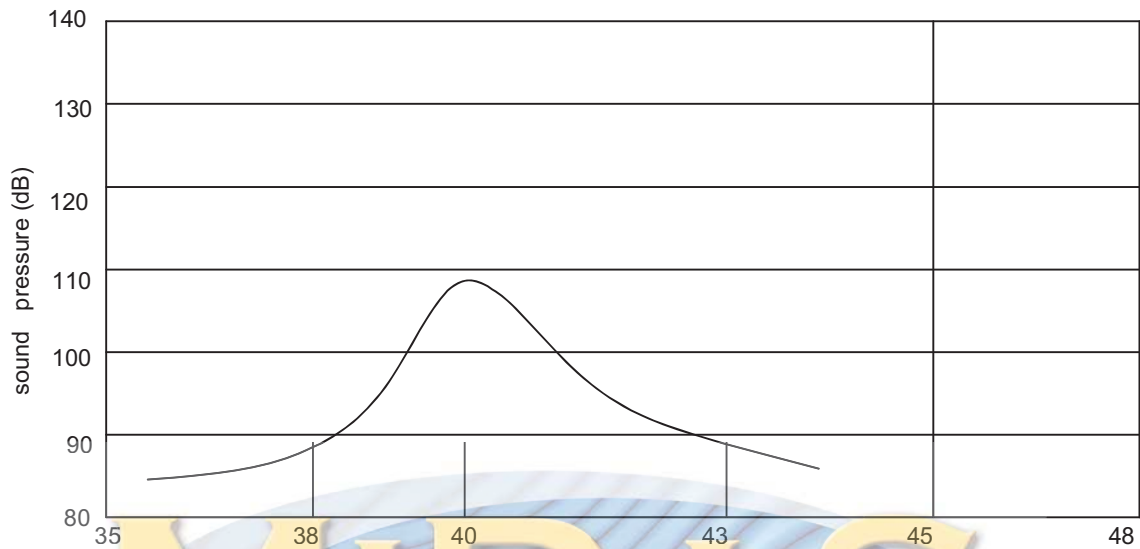

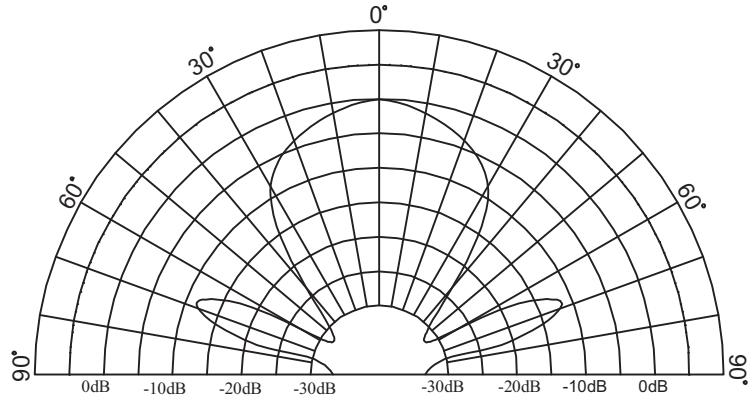

Directivity in Overall Sensitivity

6. Test circuit

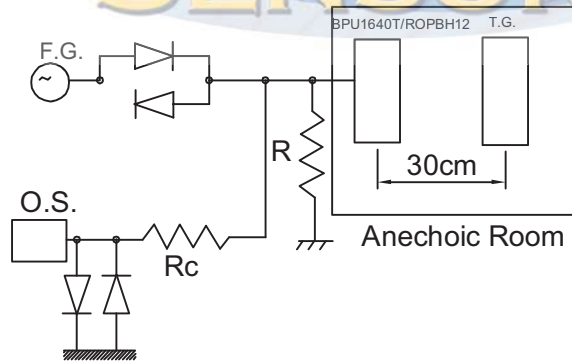

R: 3.9K Ω Rc=1k Ω

T.G. :Target
 F.G. :Function Generator
 O.S. :Oscilloscope

7. Reliability Test

7.1	High temp.life test	
	Temperature	+85±3 °C
	Duration	100hrs
7.2	Low temp.life test	
	Temperature	-40±3 °C
	Duration	100hrs
7.3	Heat Cycle Test	
	Temperature	+85±3 °C 1hour -40±3 °C 1hour
	Cycles	10cycles
7.4	Humidity Test	
	Temperature	+60±2 °C
	Relative Humidity	90~95%
	Duration	100hrs
	Tests above should be measured after leaving normal temperature for 24hrs.	
7.5	Vibration Test	
	Vibration Frequency	10~55Hz
	Sweep Period	1min
	Amplitude(peak to peak)	1.5mm
	Direction	3(x.y&z)
	Time	2hours/direction
7.6	Shock test	
	Acceleration	sine 100G
	Direction	3directions
	Shock time	3 time/directions
7.7	Drop test	
	Height	1m on concrete floor
	Times	2times
7.8	Connector soldering check:	
	Immersing terminal up to 1mm below base in soldering bath at 260 °C 10 seconds	

Notice:

The variation of the S.P.L or the sensitivity at 40KHz is within 3dB compared with initial figures at 25 °C in 24 hours after above test condition.

8. Caution

8.1 Limitation of Applications

Please contact us before using our product for the applications listed below which require especially high reliability for the prevention of defects which might directly cause damage to the third party's life, body or property.

- 1) Aircraft equipment
- 2) Aerospace equipment
- 3) Undersea equipment
- 4) Power plant control equipment
- 5) Medical equipment
- 6) Transportation equipment (vehicles, train, ships, etc.)
- 7) Traffic signal equipment
- 8) Disaster prevention/crime prevention equipment
- 9) Data-processing equipment
- 10) Application of similar complexity and/or reliability requirement to the applications listed in the above

8.2 Fail -safe

Be sure to provide an appropriate fail-safe function on your product to prevent a second damage

that may be caused by the abnormal function or the failure of our product

9. Caution in use

- 1) Please avoid applying an excessive stress to the transducer because it might be damaged.
- 2) The transducer may generate surge voltage by mechanical or thermal shock. Care should be taken to protect from it in designing your application circuit.
- 3) Please do not apply DC voltage to the transducer.
- 4) Please do not use the transducer in water.
- 5) The piece of sensor may be damaged by force pressure from back of sensor.
- 6) Please do not use the sensor without painting on the surface.
- 7) Please well evaluate the painting and electrical characteristic for your coating.

10. Note

- 1) Please make sure that your product has been evaluated in view of your specifications with our product being mounted to your product.
- 2) You are requested not to use our product deviating from the agreed specifications.
- 3) We consider it not appropriate to include any terms and conditions with regard to the business transaction in the product specifications, drawings or other technical documents. Therefore, of your technical documents as above include such terms and conditions such as warranty clause, product liability clause, or intellectual property infringement liability clause, they will be deemed to be invalid

11.Packing

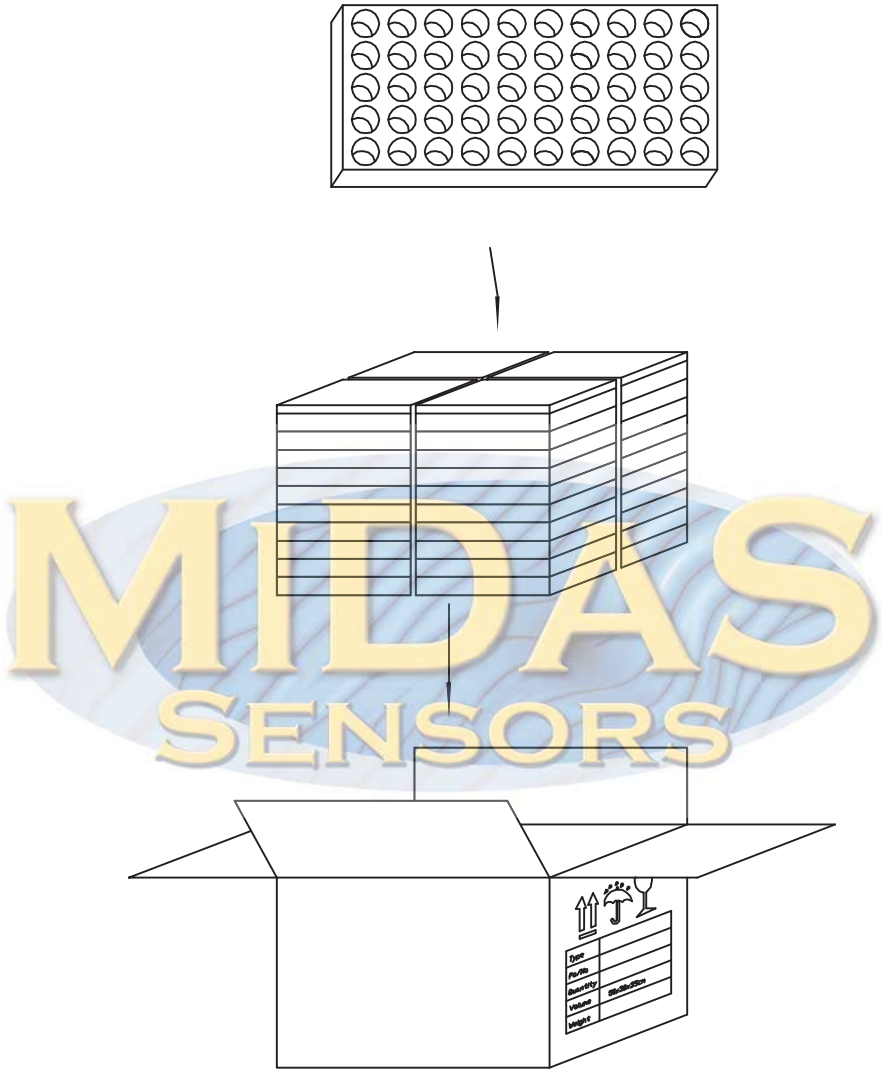

- Quantity: { 50 PCS/Foam tray
- { 40 Foam tray/Box
- { 2000 PCS/Box

12. History change record

version No.	Change Items		Date	Drawn	Approved
	Before	After			
A			2010.12.15	倪雪晴	

