

T-1 Super Brite LED Lamps

Description and Features

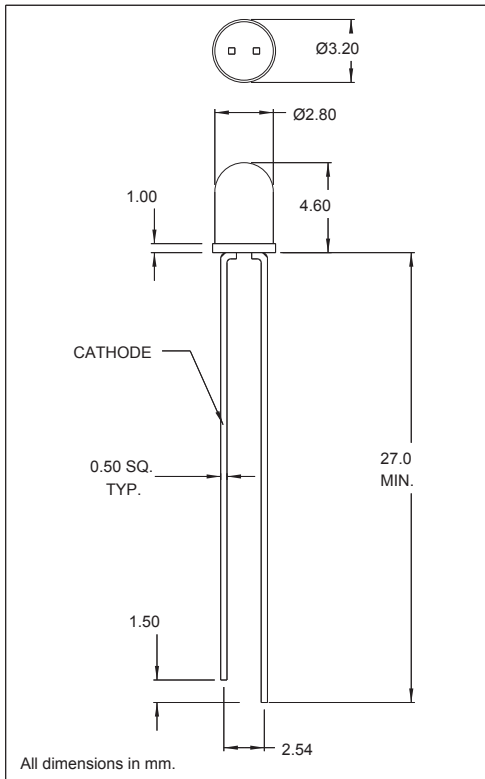

These T-1 LED lamps provide superior brightness compared to conventional LED lamps through the use of GaAlAs and improved GaP technologies. Intensities as high as 400 millicandela can be achieved with these lamps making them excellent choices for indicators in high ambient lighting conditions as well as for backlighting.

Electro-Optical Characteristics and Ratings

PART NUMBER	CMD264-3UGD	CMD264-3SRD/L2	CMD264-3URD	CMD264-3UGC	CMD264-3URC
Output Color	Green	Red	Red	Green	Red
Diffusion	Diffused	Diffused	Diffused	Non-Diffused	Non-Diffused
Package Color	Green	Red	Red	Clear	Clear
Test Current (mA)	20	20	20	20	20
Forward Voltage Typ. (V)	2.1	1.7	1.7	2.1	1.7
Forward Voltage Max. (V)	2.8	2.4	2.4	2.8	2.4
Luminous Intensity Min. (mcd)	25.0	40.0	100.0	100.0	250.0
Luminous Intensity Typ. (mcd)	40.0	63.0	160.0	200.0	400.0
Luminous Intensity Max. (mcd)	-	-	-	-	-
Peak Wavelength (nm)	565	660	660	565	660
Viewing Angle 2θ 1/2 (degrees)	45	40	40	30	25
Power Dissipation (mW)	105	100	100	105	100
Operating Temperature (°C)	-40 to +85	-40 to +85	-40 to +85	-40 to +85	-40 to +85
Storage Temperature (°C)	-40 to +85	-40 to +85	-40 to +85	-40 to +85	-40 to +85
Peak Forward Current Max. (1µs @ 10% duty cycle) (mA)	150	150	150	150	150
Reverse Voltage (IR=100µA) (V)	5	5	5	5	5
Lead Solder Time @ 260°C	5	5	5	5	5