

Features

- Super-luminosity LED.
- White SMT package.
- Built in Red, Green, and Blue chips.
- Lead frame package with 6 individual pins.
- Wide viewing angle.
- ESD protection.
- Pb-free.
- RoHS compliant version.



Descriptions

- 120° viewing angle.
- Low power consumption.

Device Selection Guide

Chip			Lens Color
Type	Material	Emitted Color	
R	AlGaInP	Brilliant Red	Water Clear
G	InGaN	Brilliant Green	
B	InGaN	Blue	

Package Outline Dimension and Recommended Soldering Pattern for Reflow Soldering

Unit: mm Tolerance: +/-0.1

Outline Dim.	Soldering Pattern
<p style="text-align: center;">R G B Die1 Die2 Die3 Pin 6 Pin 5 Pin 4 Pin 1 Pin 2 Pin 3 Polarity</p>	
<p>Soldering terminals may shift in the x, y direction.</p>	

Absolute Maximum Ratings (Ta=25°C)

Parameter	Symbol	Rating		Unit
Reverse Voltage	V _R	5		V
Forward Current	I _F	R	30	mA
		G	30	
		B	30	
Peak Forward Current (Duty 1/10 @ 1KHz)	I _{FP}	R	120	mA
		G	110	
		B	110	
Power Dissipation	P _d	R	80	mW
		G	110	
		B	110	
Electrostatic Discharge(HBM)	ESD	2000		V
Operating Temperature	T _{opr}	-40 ~ +85		°C
Storage Temperature	T _{stg}	-40~ +90		°C
Soldering Temperature	T _{sol}	Reflow Soldering : 260 °C for 10 sec. Hand Soldering : 350 °C for 3 sec.		

Electro-Optical Characteristics (Ta=25°C)

Parameter	Symbol	Min.	Typ.	Max.	Unit	Condition	
Luminous Intensity	I _v	R	450	-----	715	mcd	I _F =20mA
		G	900	-----	2250		
		B	225	-----	450		
Viewing Angle	2θ _{1/2}	-----	120	-----	deg	I _F =20mA	
Peak Wavelength	λ _p	R	-----	632	-----	nm	I _F =20mA
		G	518	-----	-----		
		B	-----	468	-----		
Dominant Wavelength	λ _d	R	617.5	-----	633.5	nm	I _F =20mA
		G	523.5	-----	535.5		
		B	466	-----	472		
Spectrum Radiation Bandwidth	Δλ	R	-----	20	-----	nm	I _F =20mA
		G	-----	35	-----		
		B	-----	35	-----		
Forward Voltage	V _F	R	1.75	-----	2.35	V	I _F =20mA
		G	2.75	-----	3.95		
		B	2.75	-----	3.95		
Reverse Current	I _R	R	-----	-----	10	μA	V _R =5V

Specific binning requirements- please contact our home office

Notes:

1. Tolerance of Luminous Intensity ±10%
2. Tolerance of Dominant Wavelength ±1 nm

■ **Luminous Intensity (Iv) Bin:**

Color	BinCode	Spec.Range
Red	V	450 -560mcd
	W	560 -715mcd
Green	Y	900 -1125mcd
	Z	1125 -1440mcd
	AA	1440 -1800mcd
	AB	1800 -2250mcd
Blue	S2	220 -285mcd
	T	285 -360mcd
	U	360 -450mcd

■ **Dominant Wavelength (λ_D) Bin:**

Color	BinCode	Spec.Range
Red	A	615 -620nm
	B	620 -625nm
	C	625 -630nm
Green	B	520 -525nm
	C	525 -530nm
	D	530 -535nm
Blue	A	460 -465nm
	B	465 -470nm

■ **Forward Voltage (Vf) Bin:**

Color	BinCode	Spec.Range
Red	F5	2.0 -2.2V
	F6	2.2 -2.4V
	G5	2.4 -2.6V
Green	H7	2.9 -3.1V
	H8	3.1 -3.3V
	J7	3.3 -3.5V
Blue	H7	2.9 -3.1V
	H8	3.1 -3.3V
	J7	3.3 -3.5V

Characteristics Curves

Relative Intensity vs. Forward Current

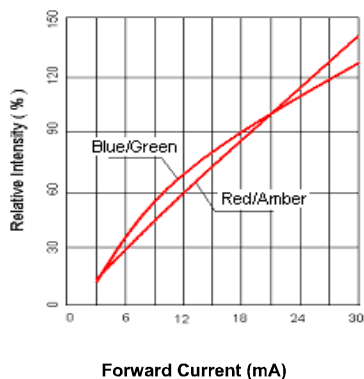

Forward Voltage vs. Forward Current

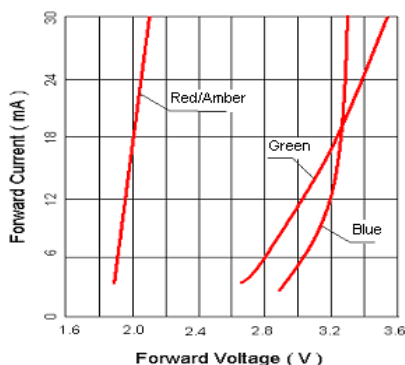

Forward Current vs. Ambient Temperature

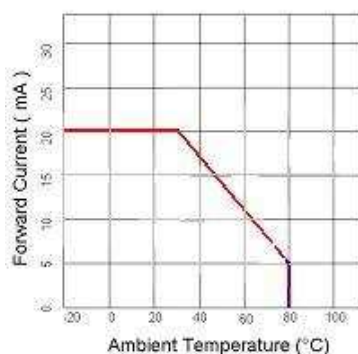

WL(nm)



WL(nm)



WL(nm)

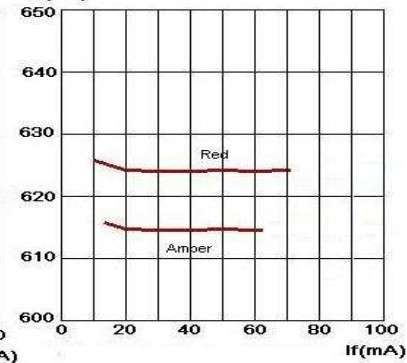

Wavelength vs. Forward Current

Directive Characteristics

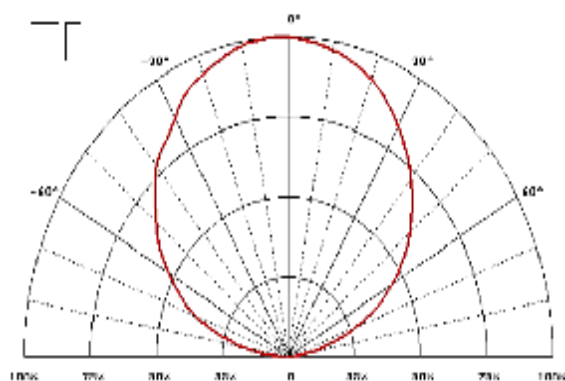

Directive Characteristics

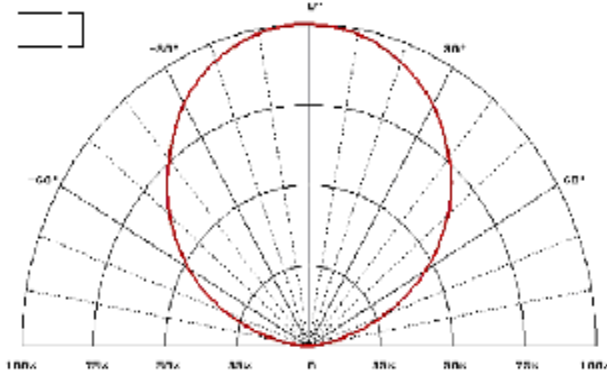

Packaging

Carrier Tape Dimensions: Loaded quantity 1000 PCS per reel.

Tape Dimension

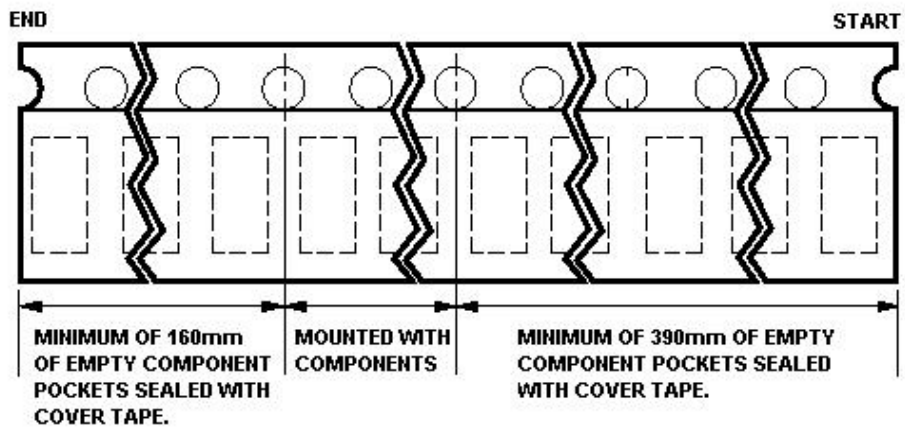
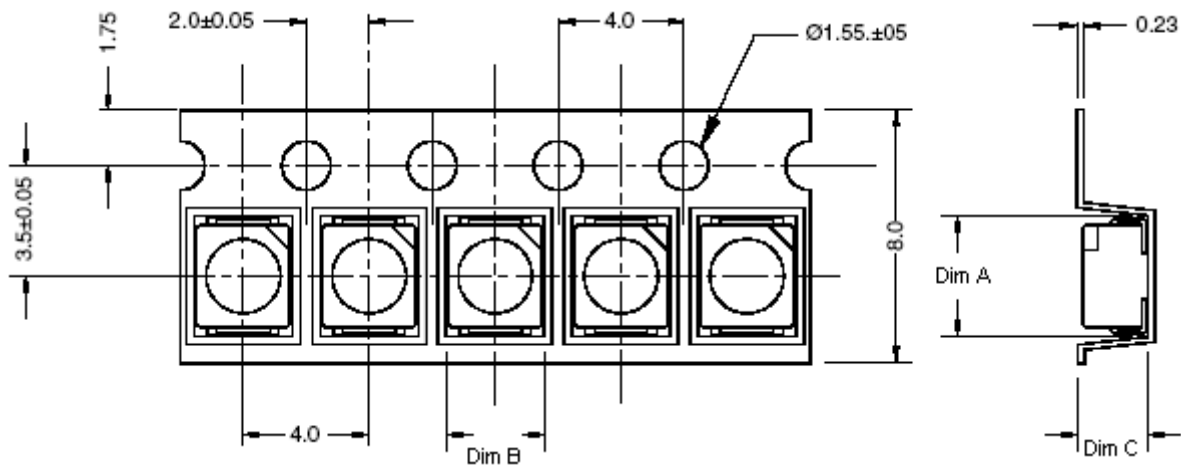

Dry Pack

All SMD optical devices are **MOISTURE SENSITIVE**. Avoid exposure to moisture at all times during transportation or storage. Every reel is packaged in a moisture protected anti-static bag. Each bag is properly sealed prior to shipment.

Upon request, a humidity indicator will be included in the moisture protected anti-static bag prior to shipment.

Moisture Resistant Packaging

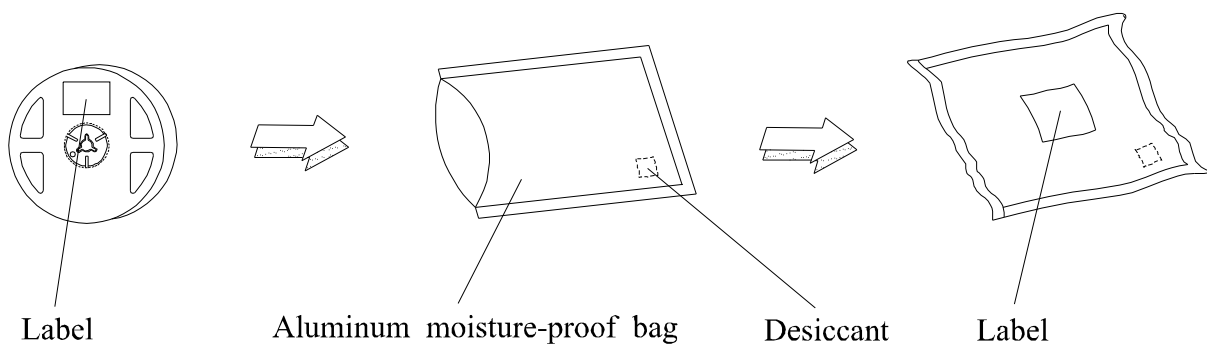

PRECAUTIONS

1. Avoid exposure to moisture at all times during transportation or storage.
2. Anti-Static precaution must be taken when handling GaN, InGaN, and AlInGaP products.
3. It is suggested to connect the unit with a current limiting resistor of the proper size. Avoid applying a reverse voltage beyond the specified limit.
4. Avoid operation beyond the limits as specified by the absolute maximum ratings.

Reflow Soldering

- Recommended tin glue specifications: melting temperature in the range of 178~192 °C
- The recommended reflow soldering profile is as follows (temperatures indicated are as measured on the surface of the LED resin):

Lead Solder Profile

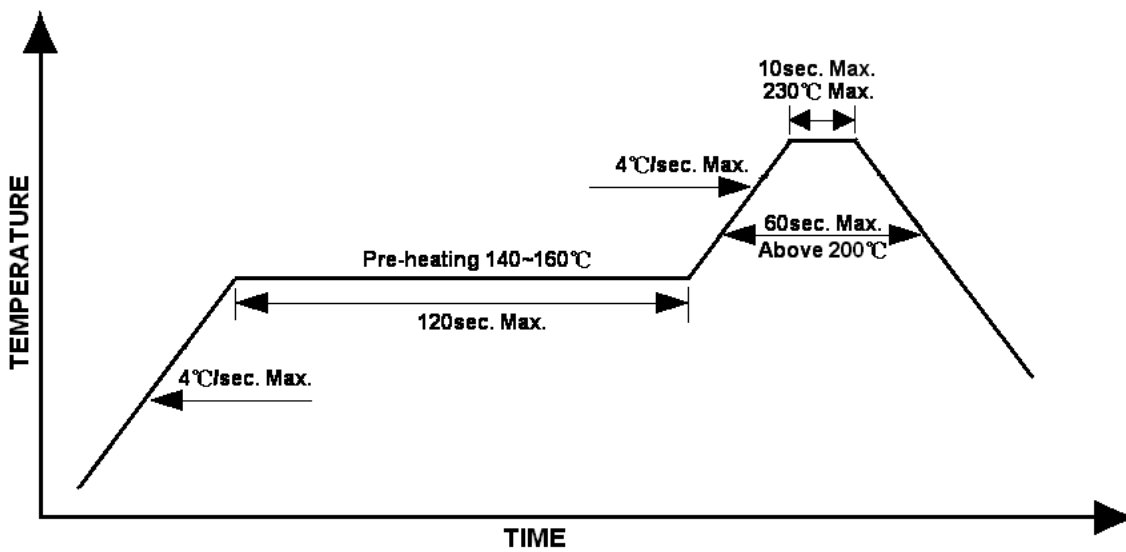

Lead-free Solder Profile

