

## HIGH EFFICIENCY STEP DOWN LED DRIVER

### Features

- RoHS-compliant 24 Pin DIL Package wired version
- Constant Current Output (  $\pm 7\%$  Output Current Accuracy )
- LED Driver Current 150 / 250 / 300 / 350 / 500 / 600 / 700 / 1000 mA
- Power LED Driver
- Wide Input Voltage Range: 7V to 60V ( 65V for 0.5sec. )
- Output Power 9 / 14 / 17 / 20 / 29 / 34 / 40 / 48W
- Driver LED Strings of up to 57V ( 2V to 57V )
- High Efficiency ( up to 97% )
- PWM/Digital Dimming and Analog Voltage Dimming
- Open and Short LED Protection
- $-40^{\circ}\text{C} \sim 85^{\circ}\text{C}$  Operation Temperature Range
- With MLCC Capacitors only
- IP67 rated

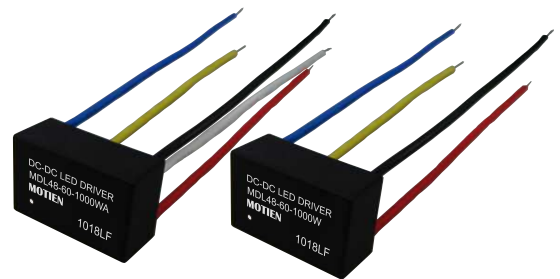

### Application

- 12V, 24V, 36V and 48V Lighting Systems
- Household/Commercial lighting
- Suitable for high illumination LED
- Power limited ( battery ) lighting system

**M**DL48W(WA) Series is a high efficiency step-down converter optimized to drive high current LEDs. The control algorithm allows highly efficient and accurate LED current regulation. The device operates from an input 7Vdc to 60Vdc and provides an externally adjustable output current of up to 1000mA and output power up to 48 watts. Compact size of DIL24 allows designer to integrate this driver together with LED module. UL94V-0 grade molded case with high grade filling material provide excellent fire proof characters.

(Typical at  $T_a = +25^{\circ}\text{C}$ , nominal input voltage, rated output current unless otherwise specified.)

Electrical Specifications:		PWM Dimming and ON/OFF Control (Leave Open if Not Used) For WA	
Input Voltage (Vdc)	7V ~ 60V (65V for 0.5 sec)	Remote ON/OFF	
Input Filter	Capacitor	DC/DC ON	Open or $0.3\text{V} < V_{\text{ADJ}} < 1.25\text{V}$
Output Voltage Range ( $V_{\text{in}} = 60\text{V}$ )	2V to 57V	DC/DC OFF (Shutdown)	$V_{\text{ADJ}} < 0.15\text{V}$
Output Current Range ( $V_{\text{in}} - V_{\text{out}} > 3\text{V}$ )	See table	Remote Pin Drive Current ( $V_{\text{ADJ}} = 1.25\text{V}$ )	$< 1\text{mA}$
Output Current Accuracy	See table	Quiescent Input Current in Shutdown Mode ( $V_{\text{in}} = 60\text{V}$ )	100uA Max.
Output Power	See table	PWM Dimming	
Ripple and Noise, (20 MHz bandwidth)	See table	Recommended Maximum Operation Frequency	1KHz
Maximum Efficiency at Full Load	97%	Adjust Output Current (PWM Frequency $< 300\text{Hz}$ )	0.1% to 100%
Capacitive Load	470uF	Analog Dimming Control (Leave Open if Not Used) For WA	
Operating Frequency	20 kHz ~ 500 kHz	$V_{\text{ADJ}}$ Input Voltage Range	0.3V to 1.25V
Short Circuit Protection	Regulated at Rated Output Current	Adjust Output Current ( $V_{\text{in}} - V_{\text{out}} < 30\text{V}$ )	25% to 100%
Temperature Coefficient	$\pm 0.03\%/^{\circ}\text{C}$ Max.	Control Voltage Range Limits	
Thermal Impedance (Nature Convection)	$+30^{\circ}\text{C}/\text{W}$	ON	0.2V ~ 0.3V
Safety Standard : (designed to meet)	IEC / EN 60950-1	OFF	0.15V ~ 0.25V
Environmental Specifications		Analog Pin Drive Current ( $V_{\text{ADJ}} = 1.25\text{V}$ )	$< 1\text{mA}$
Operating Temperature Range	$-40^{\circ}\text{C}$ to $+85^{\circ}\text{C}$ (See Derating Curve)	Physical Specifications	
Storage Temperature Range	$-40^{\circ}\text{C}$ to $+125^{\circ}\text{C}$	Case Material	Non-Conductive Black Plastic (UL94V-0 rated)
Environmental	IP67	Potting Material	Epoxy (UL94V-0 rated) Silicon (UL94V-0 rated)
Maximum Case Temperature	$+110^{\circ}\text{C}$	Lead wires	UL 1015/CSA TEM listed/ 22AWG / 600V/ 105°C Rated
Cooling	Nature Convection	Weight	18.0g
Reliability Calculated MTBF (MIL-HDBK-217 F)	$> 950\text{ Khrs}$	Dimensions	1.25"x0.80"x0.49"
Soldering Temperature (1.5mm from case 10 sec.)	$+260^{\circ}\text{C}$		
EMC Specifications (design to meet)			
EMI Radiated & Conducted Emissions	EN 55015 (CISPR22)		

### NOTE

1. Reversed power source damages the circuit, No connection is allowed between input ground and output.
2. DO NOT operate the driver over output power.
3. Leave pin  $V_{\text{ADJ}}$  open if not in use, ground pin to shut down the converter. Connecting  $V_{\text{ADJ}}$  to  $V_{\text{in}}$  damages the circuit.
4. Maximum output open voltage is equal to input voltage.

HIGH EFFICIENCY STEP DOWN LED DRIVER

PART NUMBER STRUCTURE

**MDL48 - 60 - 1000 W A**

Series Name

Input Max. Voltage

Wired Version

Output Current

- 150 - 150mA
- 250 - 250mA
- 300 - 300mA
- 350 - 350mA
- 500 - 500mA
- 600 - 600mA
- 700 - 700mA
- 1000 - 1000mA

Dimming Control Wire (Optional)

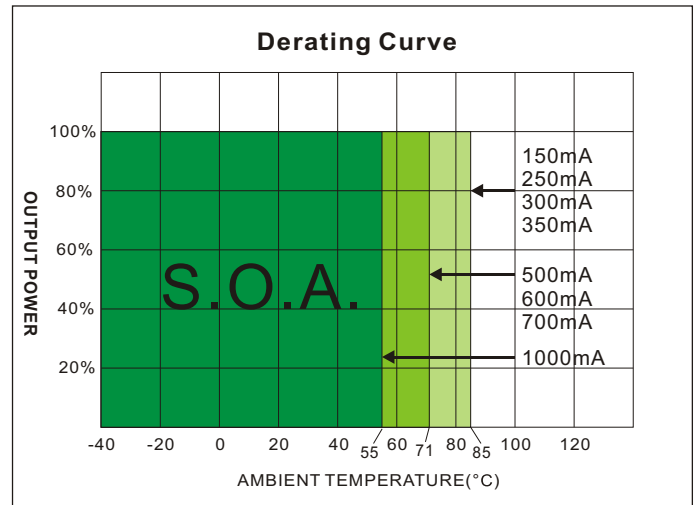

MODEL SELECTION GUIDE

MODEL NUMBER	INPUT	OUTPUT		OUTPUT Current Accuracy (%)	OUTPUT Power (W) Max.	EFFICIE NCY @FL(%) Max.	Ripple and Noise mVp-p Max.	Capacitor Load(μF)
	Voltage Range (Vdc)	Voltage Range (Vdc)	Current (mA)					
MDL48-60-150W(WA)	7-60	2 ~57	150	±8	9	97	150	470
MDL48-60-250W(WA)	7-60	2 ~57	250	±7	14	97	200	470
MDL48-60-300W(WA)	7-60	2 ~57	300	±6	17	97	250	470
MDL48-60-350W(WA)	7-60	2 ~57	350	±5	20	97	300	470
MDL48-60-500W(WA)	7-60	2 ~57	500	±5	29	97	400	470
MDL48-60-600W(WA)	7-60	2 ~57	600	±5	34	97	450	470
MDL48-60-700W(WA)	7-60	2 ~57	700	±5	40	97	500	470
MDL48-60-1000W(WA)	7-60	2 ~48	1000	±5	48	97	800	470

MECHANICAL DIMENSION

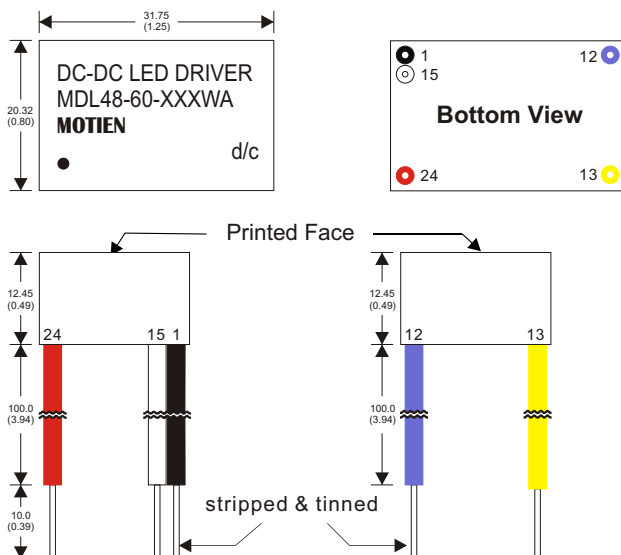

24 Pin DIL Package wired version

- Notes : All dimensions are typical in millimeters ( inches ).
1. Wire core diameter: 0.75±0.05 ( 0.02±0.002 )
  2. Wire outside diameter: 2.4±0.05
  3. Wire length = 100 + 10 stripped & tinned = 110±5 total
  4. Case Tolerance: ±0.5 ( ±0.02 )

Lead wires are under the specification of general lamps :  
Wire is UL1015/CSATEM listed #22AWG / 600V / 105° Rated

Pin #	CONNECTIONS		
		MDL48-60-XXXWA	MDL48-60-XXXW
1 (Black)	- V Input	- DC Supply	- DC Supply
15 (White)	V <sub>ADJ</sub>	PWM/ON/OFF or not used	No wires
12 (Blue)	- V Output	LED Cathode Connection	LED Cathode Connection
13 (Yellow)	+V Output	LED Anode Connection	LED Anode Connection
24 (Red)	+V Input	+DC Supply	+DC Supply

No connection is allowed between input and output

HIGH EFFICIENCY STEP DOWN LED DRIVER

Typical Operating Conditions

MDL48-60-150WA

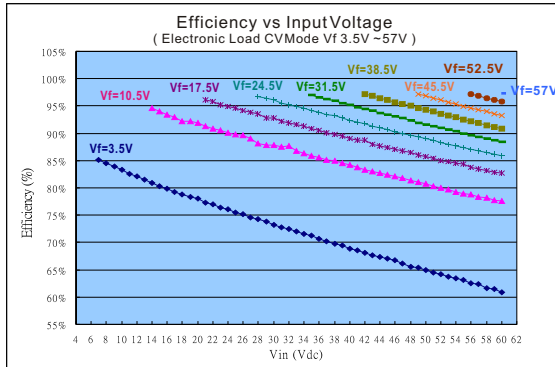

MDL48-60-500WA

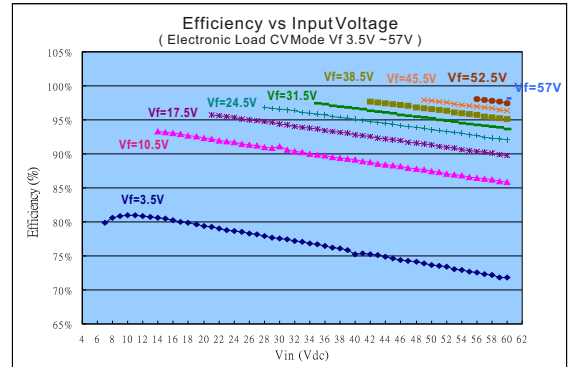

MDL48-60-250WA

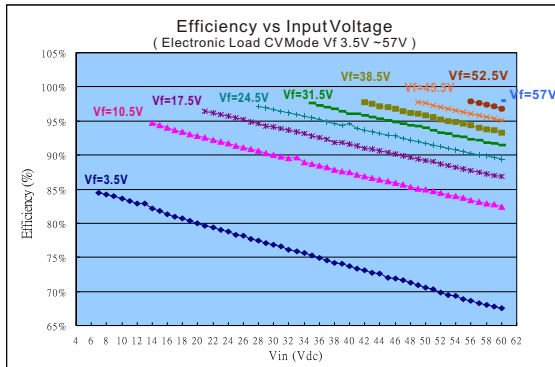

MDL48-60-700WA

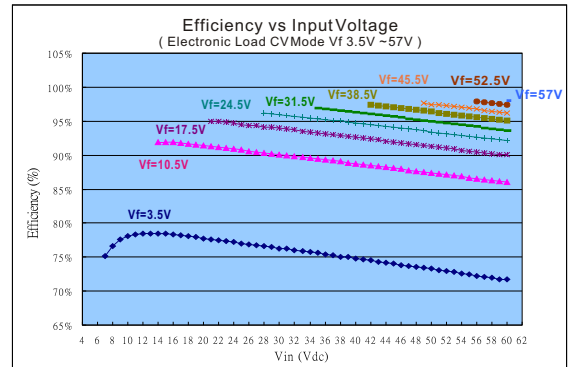

MDL48-60-300WA

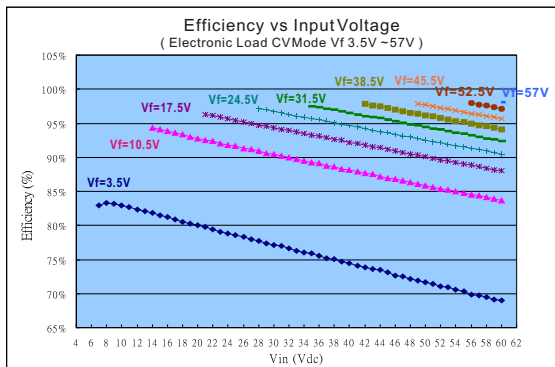

MDL48-60-1000WA

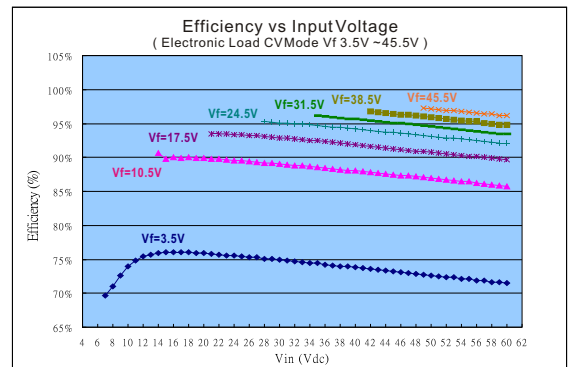

MDL48-60-350WA

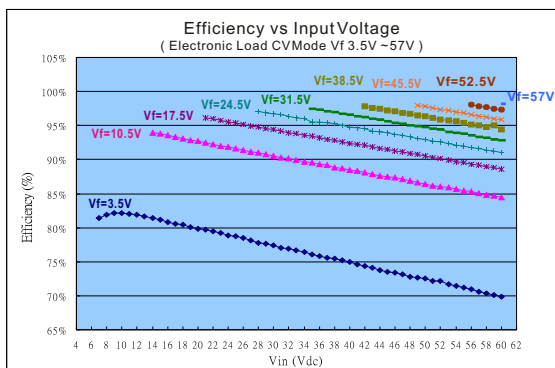

HIGH EFFICIENCY STEP DOWN LED DRIVER

EMC Characteristics meet EN55022

EN55015 Conduction Class B Filter Suggestion

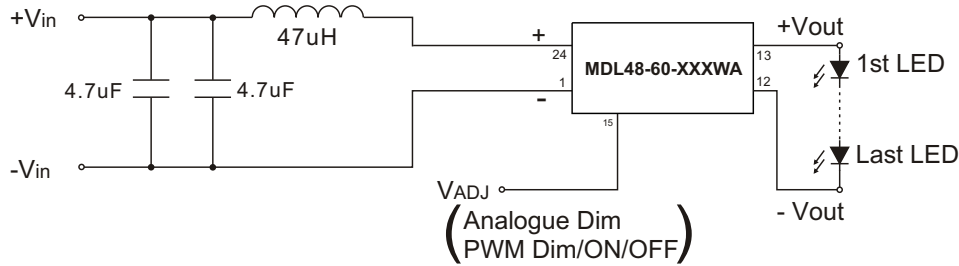

Vin=60V Vout=30V( LED Load Vf=3.3V , 9LED≐30V)

Vin=12V Vout=3.3V( LED Load Vf=3.3V , 1LED≐30V)

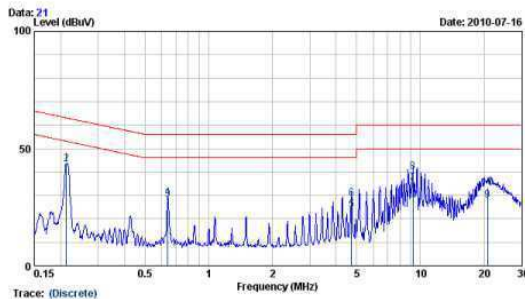

Freq. MHz	LISN Factor dB	Cable Loss dB	Meter Reading dBuV	Measured Level dBuV	Limits dBuV	Over Limits dBuV	Detector
0.213	9.93	0.03	33.77	43.73	63.10	-19.36	QP
0.213	9.93	0.03	33.37	43.33	53.10	-9.76	AVERAGE
0.641	9.95	0.06	18.14	28.15	46.00	-17.85	QP
0.641	9.95	0.06	18.84	28.85	56.00	-27.15	QP
4.721	9.96	0.06	13.66	23.68	46.00	-22.32	AVERAGE
4.721	9.96	0.06	18.66	28.68	56.00	-27.32	QP
9.212	110.01	0.07	24.91	34.99	50.00	-15.01	AVERAGE
9.212	110.01	0.07	29.72	39.80	60.00	-20.20	QP
20.814	110.04	0.12	17.76	27.91	50.00	-22.09	AVERAGE
20.814	110.04	0.12	23.23	33.38	60.00	-26.62	QP

REMARKS: 1. Level(dBμV/m)=Read Level(dBμV)+Antenna Factor(dB/m)+Cable loss(dB)  
2. Over Limit value(dB)=Level(dBμV/m)-Limit Line(dBμV/m)

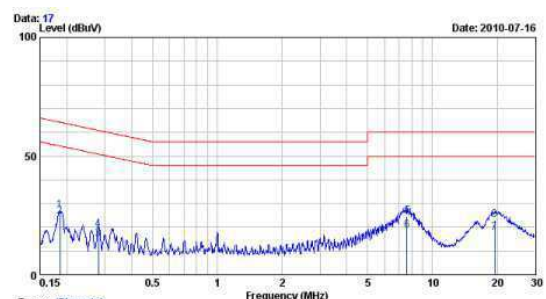

Freq. MHz	LISN Factor dB	Cable Loss dB	Meter Reading dBuV	Measured Level dBuV	Limits dBuV	Over Limits dBuV	Detector
0.185	9.92	0.04	16.97	26.92	64.24	-37.32	QP
0.185	9.92	0.04	14.56	24.51	54.24	-29.73	AVERAGE
0.280	9.95	0.04	5.10	15.10	50.81	-35.71	AVERAGE
0.280	9.95	0.04	9.09	19.09	60.81	-41.72	QP
7.606	9.99	0.08	14.56	24.63	60.00	-35.37	QP
7.606	9.99	0.08	8.70	18.77	50.00	-31.23	AVERAGE
19.428	110.03	0.10	7.33	17.46	50.00	-32.54	AVERAGE
19.428	110.03	0.10	12.82	22.95	60.00	-37.05	QP

REMARKS: 1. Level(dBμV/m)=Read Level(dBμV)+Antenna Factor(dB/m)+Cable loss(dB)  
2. Over Limit value(dB)=Level(dBμV/m)-Limit Line(dBμV/m)

Vin=60V Vout=48V( LED Load Vf=3.3V , 14LED≐15V)

Vin=7V Vout=3.3V( LED Load Vf=3.3V , 1LED≐30V)

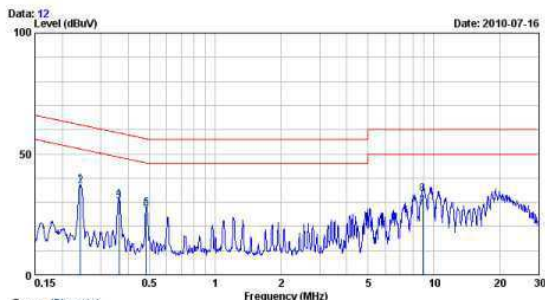

Freq. MHz	LISN Factor dB	Cable Loss dB	Meter Reading dBuV	Measured Level dBuV	Limits dBuV	Over Limits dBuV	Detector
0.242	9.94	0.04	27.29	37.27	62.04	-24.77	QP
0.242	9.94	0.04	26.56	36.54	52.04	-15.50	AVERAGE
0.363	9.95	0.05	20.52	30.52	48.65	-18.13	AVERAGE
0.363	9.95	0.05	21.22	31.22	58.65	-27.43	QP
0.484	9.94	0.06	17.42	27.42	56.27	-28.85	QP
0.484	9.94	0.06	16.58	26.58	46.27	-19.69	AVERAGE
8.869	110.00	0.07	17.71	27.79	50.00	-22.21	AVERAGE
8.869	110.00	0.07	23.20	33.28	60.00	-26.72	QP

REMARKS: 1. Level(dBμV/m)=Read Level(dBμV)+Antenna Factor(dB/m)+Cable loss(dB)  
2. Over Limit value(dB)=Level(dBμV/m)-Limit Line(dBμV/m)

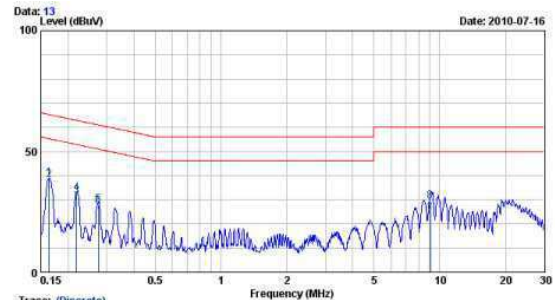

Freq. MHz	LISN Factor dB	Cable Loss dB	Meter Reading dBuV	Measured Level dBuV	Limits dBuV	Over Limits dBuV	Detector
0.163	9.91	0.04	28.96	38.91	65.30	-26.38	QP
0.163	9.91	0.04	28.15	38.10	55.30	-17.19	AVERAGE
0.219	9.93	0.03	21.65	31.62	52.88	-21.26	AVERAGE
0.219	9.93	0.03	22.81	32.78	62.88	-30.10	QP
0.274	9.95	0.04	17.94	27.93	60.98	-33.05	QP
0.274	9.95	0.04	17.26	27.25	50.98	-23.73	AVERAGE
9.059	110.00	0.07	14.24	24.32	50.00	-25.68	AVERAGE
9.059	110.00	0.07	19.41	29.49	60.00	-30.51	QP

REMARKS: 1. Level(dBμV/m)=Read Level(dBμV)+Antenna Factor(dB/m)+Cable loss(dB)  
2. Over Limit value(dB)=Level(dBμV/m)-Limit Line(dBμV/m)

HIGH EFFICIENCY STEP DOWN LED DRIVER

Typical Application

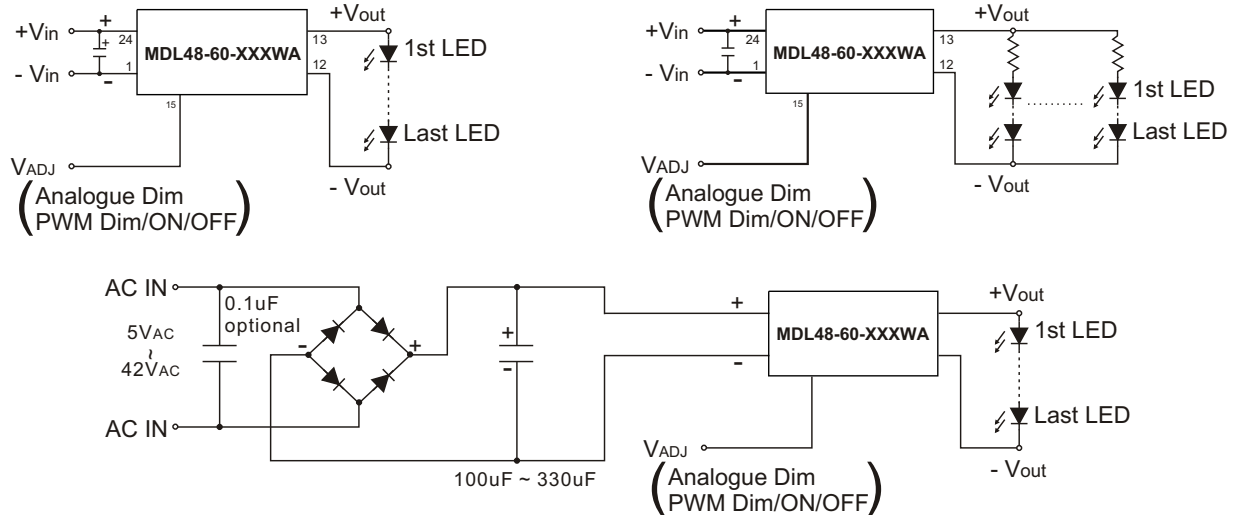

Output Current Adjustment By External DC Control Voltage (V<sub>CTRL</sub>)

$V_{ADJ} = V_{CTRL}$  [If  $V_{CTRL} = 0 \sim 1.25V_{dc}$ ]

$V_{ADJ} = \frac{R2}{R1 + R2} \times V_{CTRL}$  [If  $V_{CTRL} > 1.25V_{dc}$ ]

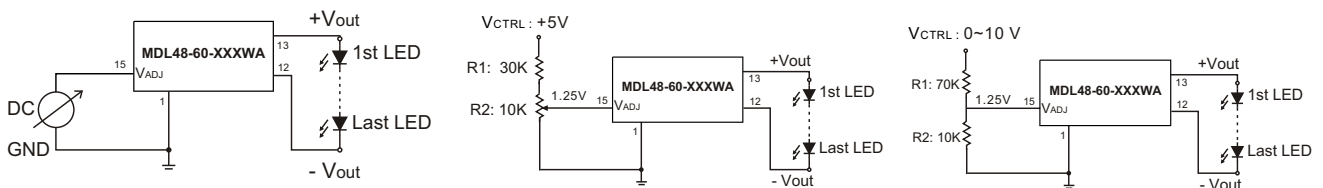

$V_{ADJ} = \frac{R3}{R2 + R3} \times 2.5$  [If  $V_{CTRL} = V_{in}$ ]

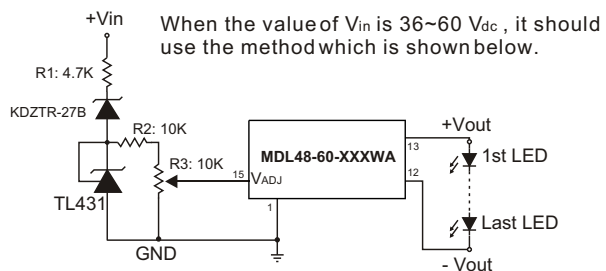
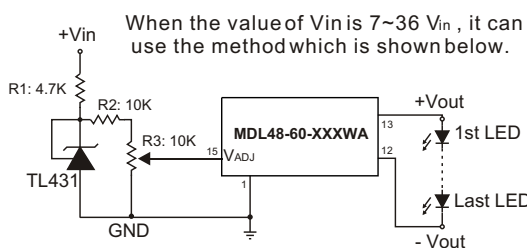

When the value of  $V_{in}$  is 36~60  $V_{dc}$ , it should use the method which is shown below.

The nominal output current ( $I_{outnom}$ ) is given by:  $I_{outnom} \approx I_{out} \times \frac{V_{ADJ}}{1.25}$

Resistor dimming

By connecting a variable resistor between ADJ and GND, simple dimming can be achieved. Capacitor  $C_{ADJ}$  is optional for better AC mains interference and HF noise rejection. Recommend value of  $C_{ADJ}$  is 0.22uF.

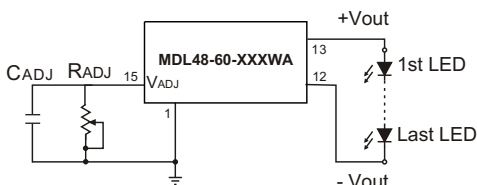

The current output  $I_{outnom}$  can be determined using the equation:

$I_{outnom} = \frac{I_{out} \times R_{ADJ}}{(R_{ADJ} + 50K)}$

If the value of  $R_{ADJ}$  is 0 to 2M ohm, the maximum adjust range of output current is 25% to 90%. (For  $V_{in} - V_{out} < 30V$ )

## HIGH EFFICIENCY STEP DOWN LED DRIVER

### Typical Application

### Output Current Adjustment By PWM Control

#### Directly driving ADJ input

A Pulse Width Modulated (PWM) signal with duty cycle DPWM can be applied to the ADJ pin, as shown below

$$I_{outnom} \approx I_{out} \times DPWM \quad [\text{if PWM frequency} < 300\text{Hz, for } 0.001 < DPWM < 1]$$

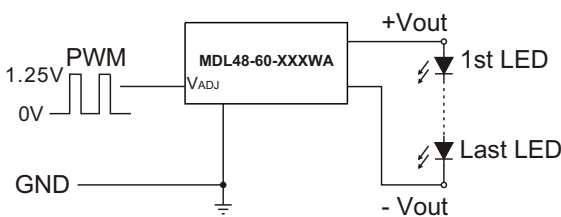

#### Driving the ADJ input via open collector transistor

The diode and resistor suppress possible high amplitude negative spikes on the ADJ input resulting from the drain-source capacitance of the transistor. Negative spikes at the input to the device should be avoided as they may cause errors in output current, or erratic device operation.

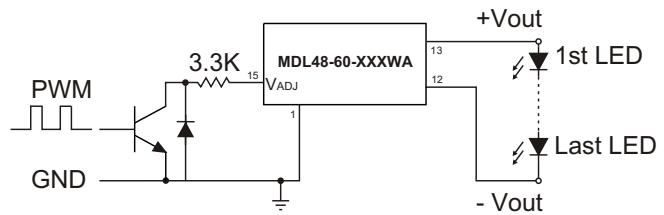

#### Driving the ADJ input from a microcontroller

Another possibility is to drive the device from the open drain output of a microcontroller. The diagram below shows one method of doing this:

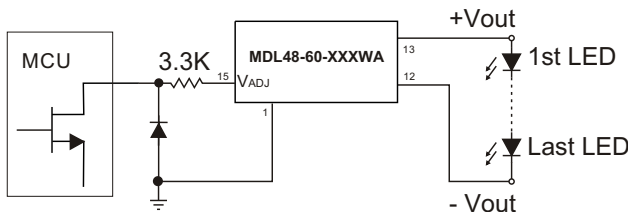

The diode and resistor suppress possible high amplitude negative spikes on the ADJ input resulting from the drain-source capacitance of the FET. Negative spikes at the input to the device should be avoided as they may cause errors in output current, or erratic device operation.

### Output Current Adjustment By PWM Control (Dimming)

To avoid visible flicker the PWM signal must be greater than 100Hz.

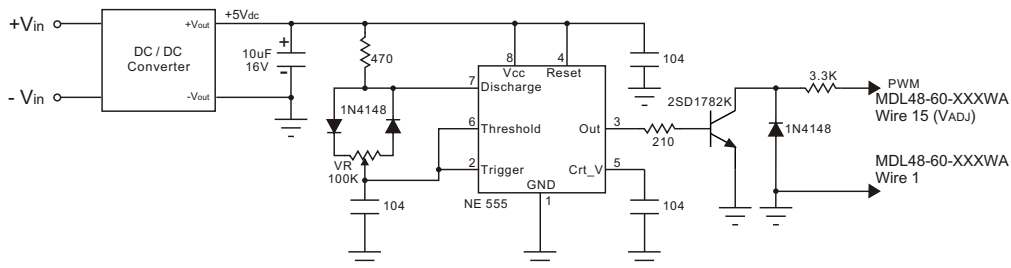

### Output Current Adjustment By PWM Control (Flash)

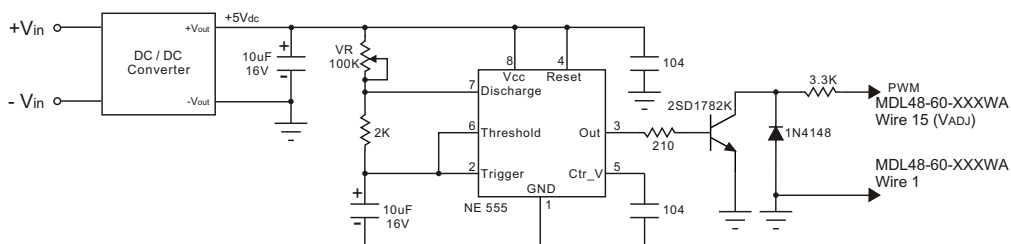

Data sheets are subject to change without notice, please check with our sales office before ordering