

Mini DomiLEDTM

With the intense colors that seem to glow with energy and its significant brightness, Mini DomiLEDTM LED is a highly reliable design device. Its dynamic nature makes it perfect choice for lighting applications, office and home applications and standard industrial applications.



Features:

- > High brightness surface mount LED.
- > Based on InGaN technology.
- > 120° viewing angle.
- > Small package outline (LxWxH) of 2.0 x 1.4 x 1.3mm.
- > Qualified according to JEDEC moisture sensitivity Level 2.
- > Compatible to both IR reflow soldering.
- > Environmental friendly; RoHS compliance.



Applications:

- > Automotive: interior applications, eg: switches, telematics, climate control system, dashboard, etc.



Optical Characteristics at Tj=25°C

Part Ordering Number	Viewing Angle°	Luminous Intensity @ IF = 10mA IV (mcd)		
		Min.	Typ.	Max.
DNZB-UJG-R2S-1	120	140.0	180.0	285.0

NOTE

1. All part number above comes in a quantity of 3000 units per reel.
2. Other luminous intensity groups are also available upon request.
3. Luminous intensity is measured with an accuracy of ± 11%.
4. Color binning is carried for all units as per the color binning table. Only one color group is allowed for each reel.

Electrical Characteristics at Tj=25°C

Part Number	Vf @ If = 10mA			Vr @ Ir = 10 µA
	Min. (V)	Typ. (V)	Max. (V)	Min. (V)
DNZB-UJG	2.7	3.2	3.7	5.0

Forward Voltage, Vf is measured with an accuracy of ± 0.1 V.

Absolute Maximum Ratings

	Maximum Value	Unit
DC forward current	20	mA
Peak pulse current; (tp ≤ 10µs, Duty cycle = 0.005)	200	mA
Reverse voltage	5	V
ESD threshold (HBM)	2000	V
LED junction temperature	125	°C
Operating temperature	-40 ... +100	°C
Storage temperature	-40 ... +100	°C
Power dissipation (at room temperature)	85	mW

DNZB-UJG, Color Grouping

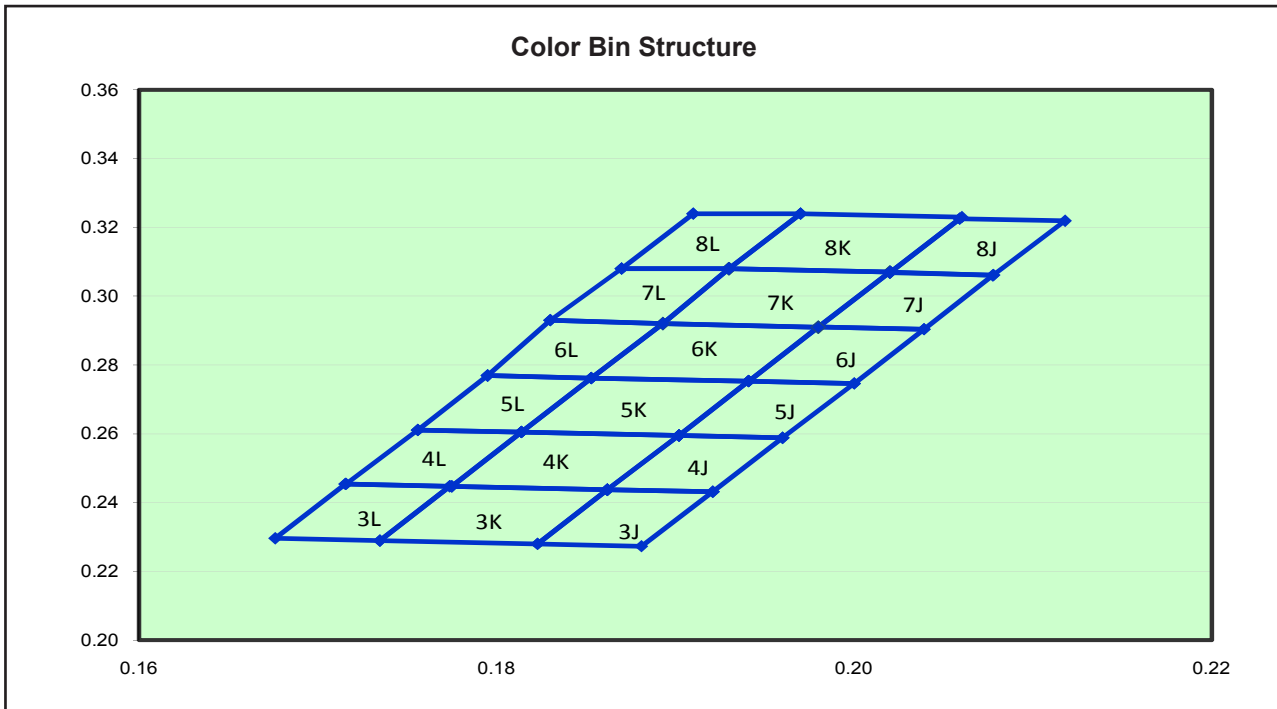

Chromaticity coordinate groups are measured with an accuracy of ± 0.01 .

Bin		1	2	3	4
3J	Cx	0.1862	0.1823	0.1881	0.1921
	Cy	0.2437	0.2280	0.2273	0.2431
3K	Cx	0.1774	0.1735	0.1823	0.1862
	Cy	0.2447	0.2289	0.2280	0.2437
3L	Cx	0.1716	0.1676	0.1735	0.1774
	Cy	0.2454	0.2296	0.2289	0.2447
4J	Cx	0.1902	0.1862	0.1921	0.1960
	Cy	0.2595	0.2437	0.2431	0.2588
4K	Cx	0.1814	0.1775	0.1862	0.1902
	Cy	0.2605	0.2447	0.2437	0.2595
4L	Cx	0.1756	0.1716	0.1775	0.1814
	Cy	0.2611	0.2454	0.2447	0.2605
5J	Cx	0.1941	0.1902	0.1960	0.2000
	Cy	0.2753	0.2595	0.2588	0.2746
5K	Cx	0.1853	0.1814	0.1902	0.1941
	Cy	0.2762	0.2605	0.2595	0.2753
5L	Cx	0.1795	0.1756	0.1814	0.1853
	Cy	0.2769	0.2611	0.2605	0.2762
6J	Cx	0.1980	0.1941	0.2000	0.2039
	Cy	0.2910	0.2753	0.2746	0.2904
6K	Cx	0.1893	0.1853	0.1941	0.1980
	Cy	0.2920	0.2762	0.2753	0.2910
6L	Cx	0.1830	0.1795	0.1853	0.1893
	Cy	0.2930	0.2769	0.2762	0.2920

Bin		1	2	3	4
7J	Cx	0.2020	0.1980	0.2039	0.2078
	Cy	0.3070	0.2910	0.2904	0.3060
7K	Cx	0.1930	0.1893	0.1980	0.2020
	Cy	0.3080	0.2920	0.2910	0.3070
7L	Cx	0.1870	0.1830	0.1893	0.1930
	Cy	0.3080	0.2930	0.2920	0.3080
8J	Cx	0.2059	0.2020	0.2078	0.2118
	Cy	0.3225	0.3068	0.3061	0.3219
8K	Cx	0.1970	0.1930	0.2020	0.2060
	Cy	0.3240	0.3080	0.3070	0.3230
8L	Cx	0.1910	0.1870	0.1930	0.1970
	Cy	0.3240	0.3080	0.3080	0.3240

Dominant color coordinate is measured with an accuracy of ± 0.01 .

Luminous Intensity Group at Tj=25°C

Brightness Group	Luminous Intensity IV (mcd)
R2	140.0 ... 180.0
S1	180.0 ... 224.0
S2	224.0 ... 285.0

Luminous intensity is measured with an accuracy of ± 11%.

Relative Luminous Intensity Vs Forward Current

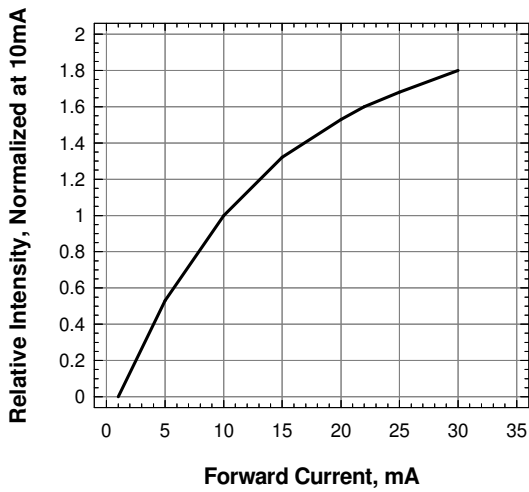

Forward Current Vs Forward Voltage

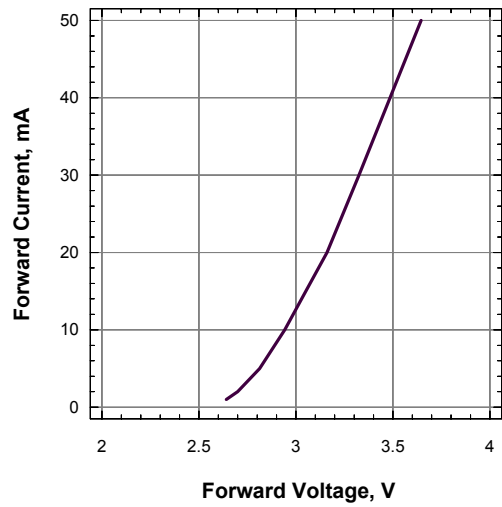

Maximum Current Vs Ambient Temperature

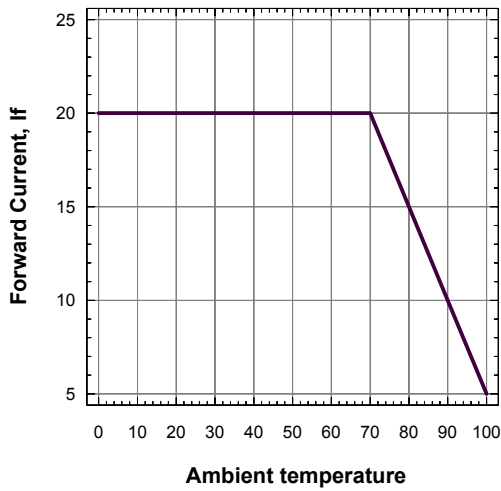

Relative Intensity Vs. Wavelength

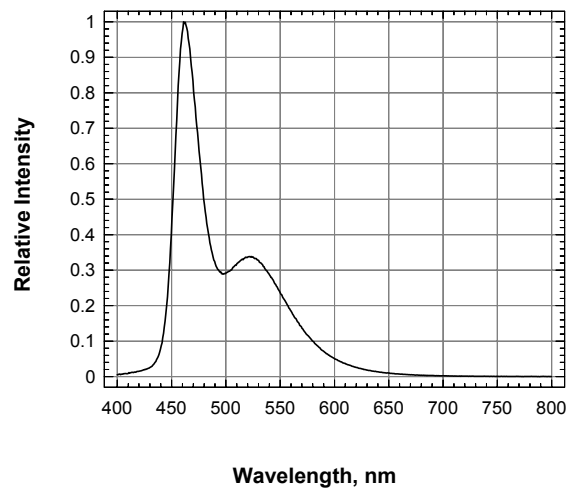

Radiation Pattern

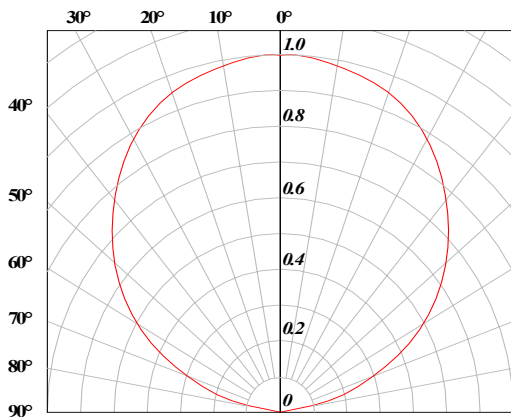

Mini DomiLED™ • InGaN : DNZB-UJG Package Outlines

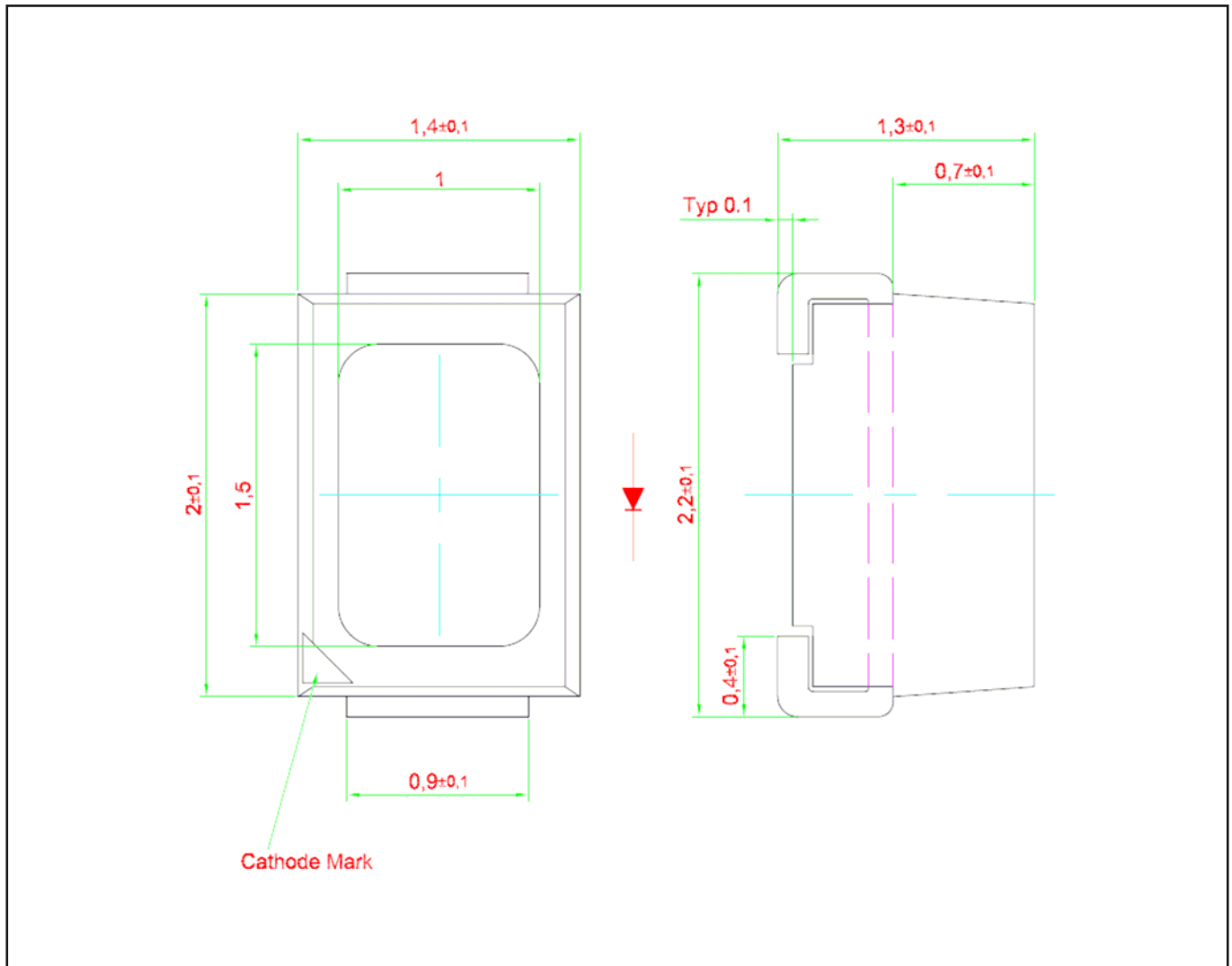

Material

	Material
Lead-frame	Copper Alloy
Package	High Temperature Resistant Plastic, PPA
Encapsulant	Silicone Resin
Soldering Leads	Pure Tin Plating, Sn

Recommended Solder Pad

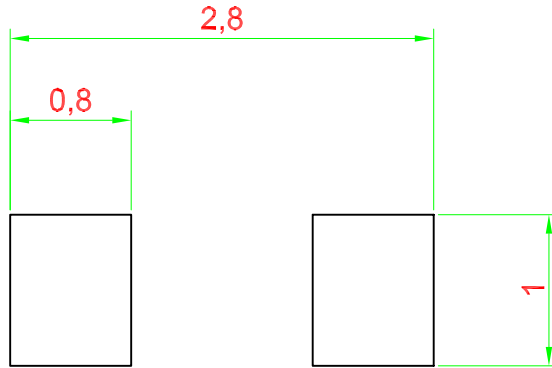

Improved Design For Better Heat Dissipation

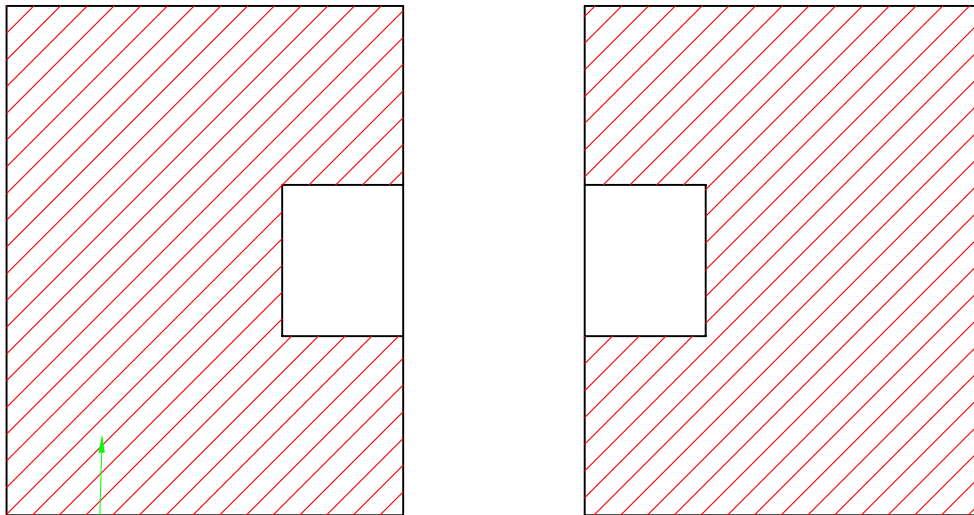

Additional Cu area for improved heat dissipation, > 16mm sq.

 Solder resist.

Packaging Specification

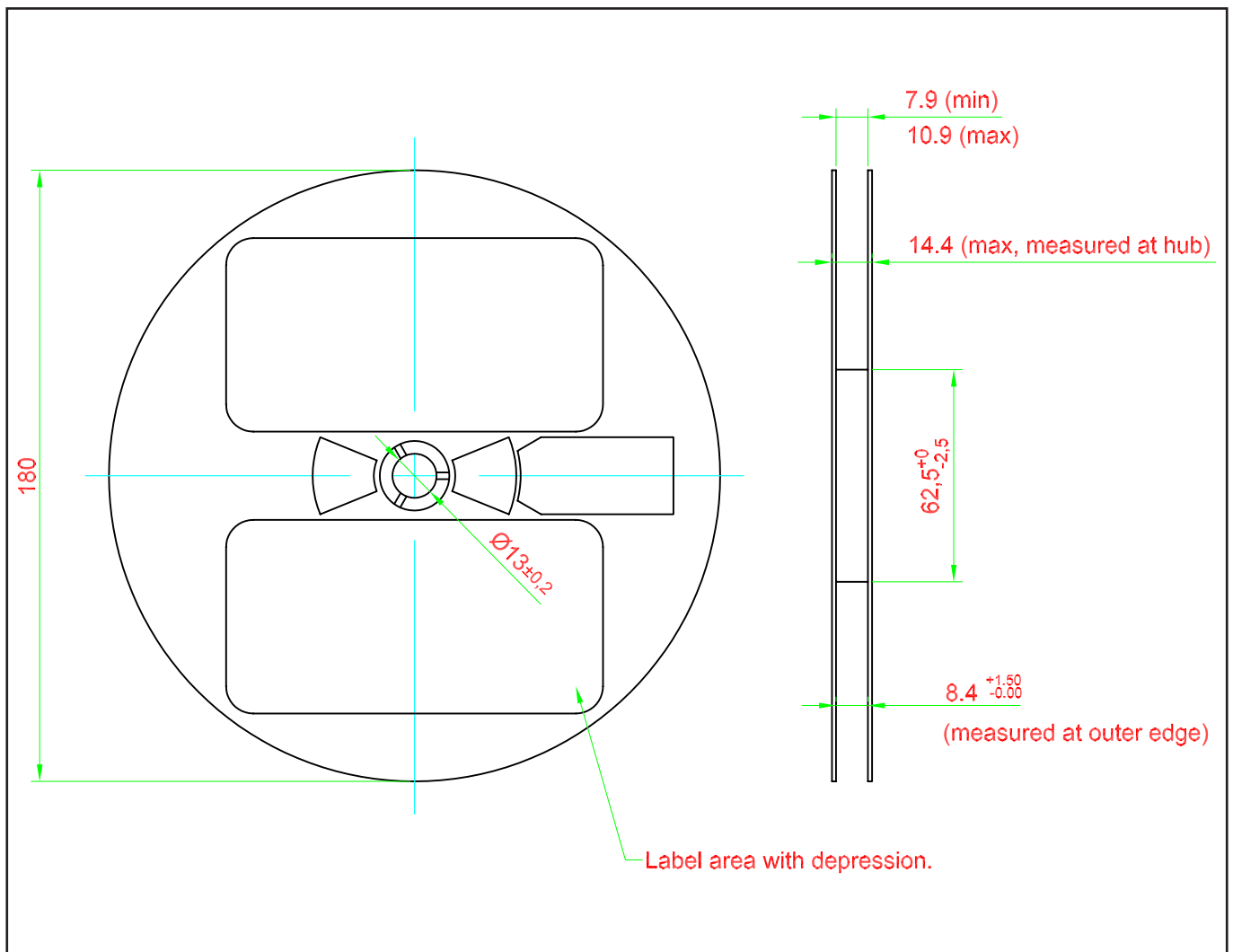

Packaging Specification

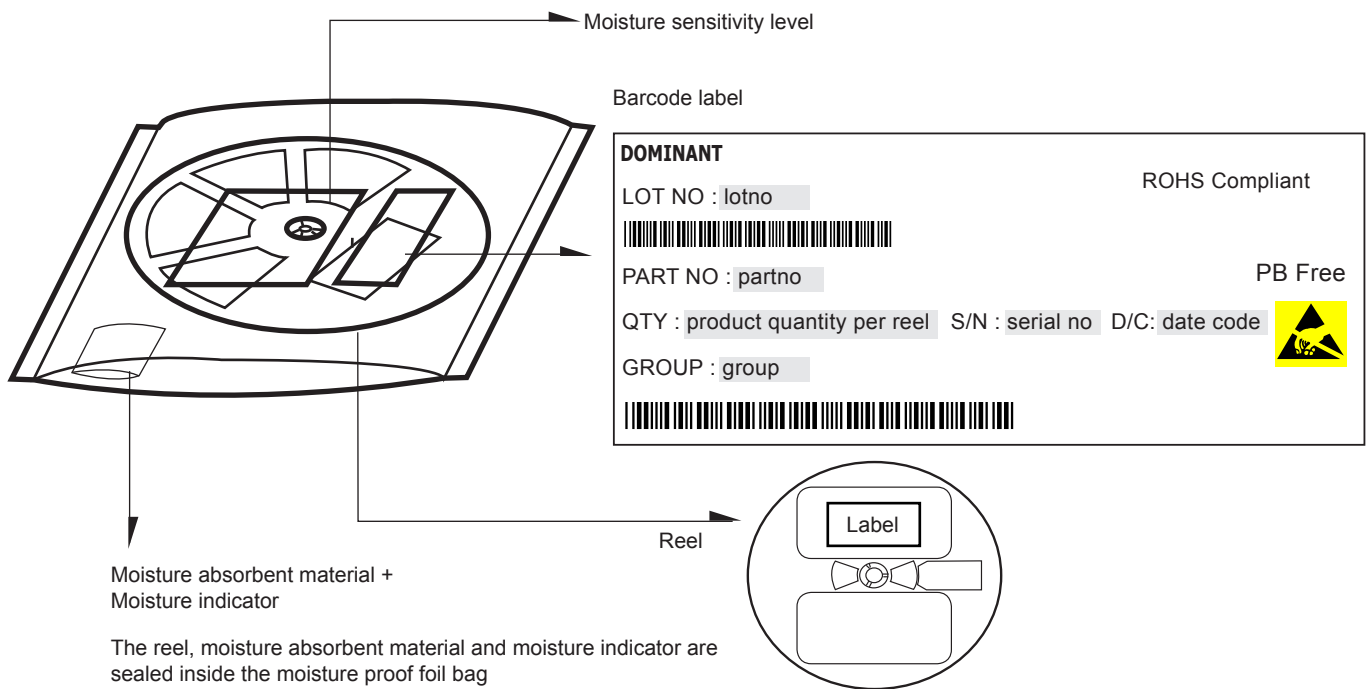

	Average 1pc Mini DomiLED	1 completed bag (3000pcs)
Weight (gram)	0.007	140 ± 10

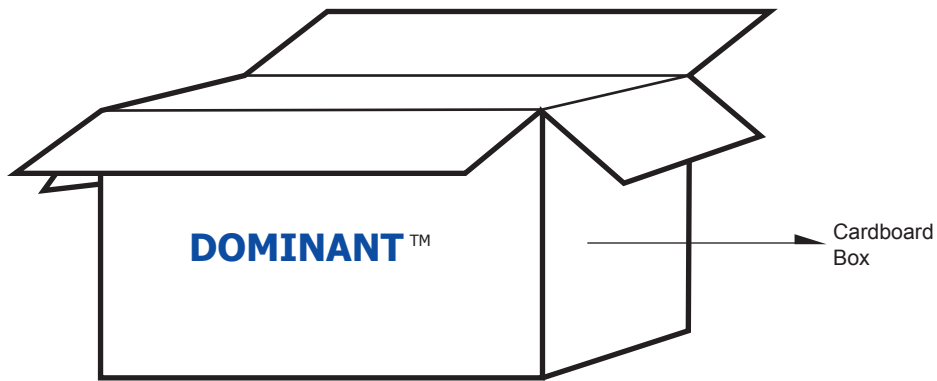

For Mini DomiLED™

Cardboard Box Size	Dimensions (mm)	Empty Box Weight (kg)	Reel / Box	Quantity / Box (pcs)
Small	300 x 250 x 250	0.58	15 reels MAX	45,000 MAX
Large	416 x 516 x 476	1.74	96 reels MAX	288,000 MAX

Recommended Pb-free Soldering Profile

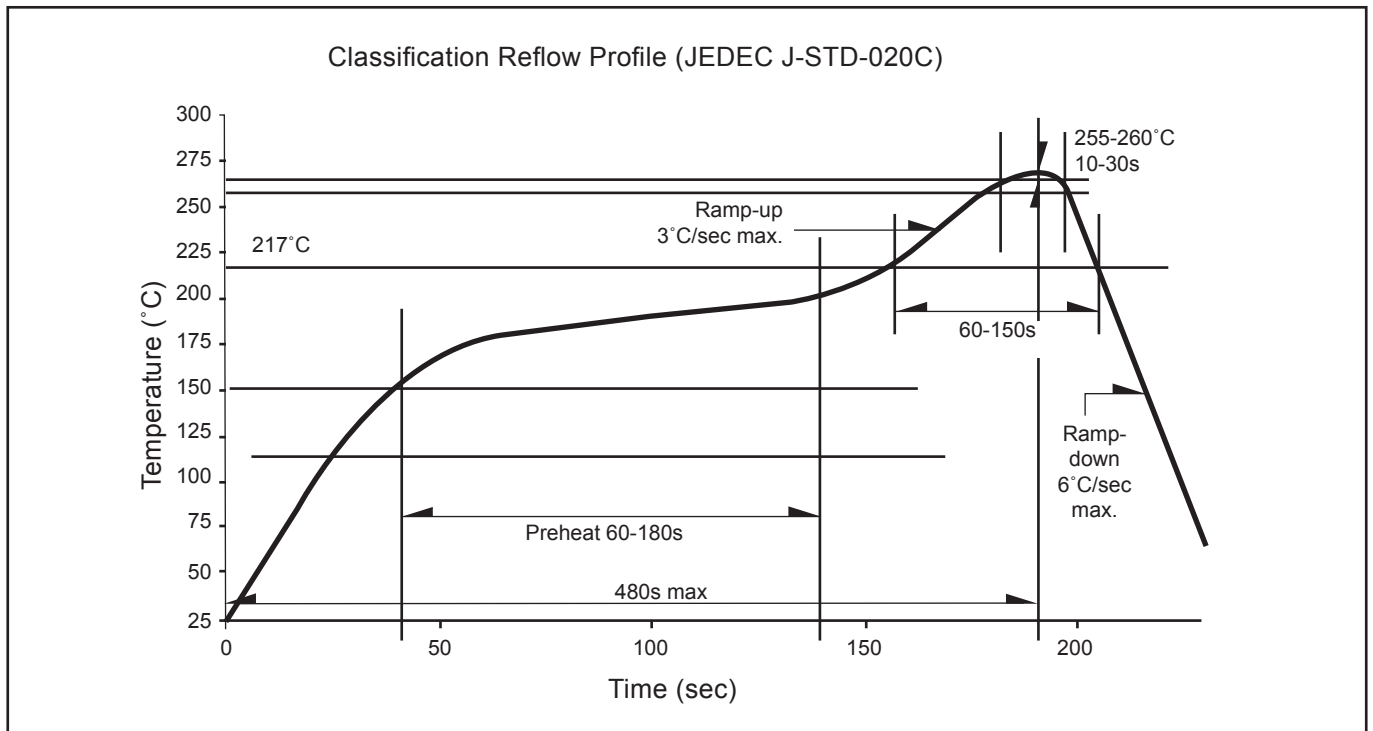

About Us

DOMINANT Opto Technologies is a dynamic Malaysian Corporation that is among the world's leading SMT LED Manufacturers. An excellence – driven organization, it offers a comprehensive product range for diverse industries and applications. Featuring an internationally certified quality assurance acclaim, DOMINANT's extra bright LEDs are perfectly suited for various lighting applications in the automotive, consumer and communications as well as industrial sectors. With extensive industry experience and relentless pursuit of innovation, DOMINANT's state-of-art manufacturing, research and testing capabilities have become a trusted and reliable brand across the globe. More information about DOMINANT Opto Technologies can be found on the Internet at <http://www.dominant-semi.com>.

Please contact us for more information:

Head Quarter

DOMINANT Opto Technologies Sdn. Bhd.
Lot 6, Batu Berendam, FTZ Phase III, 75350 Melaka, Malaysia
Tel: (606) 283 3566 Fax: (606) 283 0566
E-mail: sales@dominant-semi.com

DOMINANT Opto Technologies Sdn. Bhd. Shanghai Representative Office

Rm 305, Hongwell International Plaza No. 1600 Zhong Shan(W) Rd, Xuhui District, Shanghai, China 200235
Tel: +86 21 5403 5655, +86 21 5403 5818 Fax: +86 21 5403 6055
E-mail: sales_china@dominant-semi.com

DOMINANT Opto Technologies Sdn. Bhd. Shenzhen Representative Office

Rm 1808, Block B, South International Plaza No 3013, Yitian Road, Futian District, Shenzhen, 518048 P.R. China
Tel: +86 755 8282 1781
E-mail: sales_china@dominant-semi.com

DOMINANT Korea Sales Office

DOMINANT Semiconductors Korea Inc.
RM 211 SUNTEAK CITY APT. 513-15 Sangdaewon-dong, Jungwon-gu, Seongnam-si, Gyeonggi-do, 462-725, Korea
Tel: +82-31-701-5203 Fax: +82-31-701-5204
E-mail: sales_korea@dominant-semi.com

DOMINANT U.S.A Sales Office

25 Rockaway Road, 08833 Lebanon, New Jersey, USA
Tel: (908) 439-9930 Cell: (908) 343-5810 Fax: (908) 439-9929
E-mail: don.wendel@dominant-semi.com

DOMINANT Europe Sales Office

DOMINANT Semiconductors Europe GmbH
Raiffeisenstr. 38, 74906 Bad Rappenau Germany
Tel: +49 (0) 7264-89010-10 / +49 (0) 7264-89010-11 Cell: +49 173-6907370 / +49 173-6907751
Fax: +49 (0) 7264-89010-29
E-mail: gerd.wachno@dominant-semi.eu; hartmut.wettengl@dominant-semi.eu

DOMINANT India Sales Office

C-11, Vasanth Business Centre #86, TTK Road, Alwarpet Chennai - 600 018, INDIA
Tel: 91-44-42030616 / 516 Cell: 91-9444920537 Fax: 91-9444920616
E-mail: pravat.behera@dominant-semi.com

