

Domiled[™]

With the intense colors that seem to glow with energy and its significant brightness, Domiled[™] white LED is a highly reliable design device. Its dynamic nature makes it perfect choice for lighthing applications, office and home applications and standard industrial applications.



Features:

- > High brightness surface mount LED.
- > Based on InGaN technology.
- > 120° viewing angle.
- > Small package outline (LxWxH) of 3.2 x 2.8 x 1.8mm.
- > Qualified according to JEDEC moisture sensitivity Level 2.
- > Compatible to IR reflow soldering.
- > Environmental friendly; RoHS compliance.



Applications:

- > Automotive: interior applications, eg: switches, telematics, climate control system, dashboard, etc.
- > Consumer appliances: LCD illumination as in PDAs, LCD TV.
- > Communication: mobile phone flash light, backlights in mobile phone display.
- > Display: full color display video notice board.
- > Industrial: general lighting



Optical Characteristics at Tj=25°C

Part Ordering Number	Color	Viewing Angle°	Luminous Intensity @ IF = 20mA IV (mcd)		
			Min.	Typ.	Max.
● DDW-PJG-WX1-1	White	120	1125.0	1800.0	2240.0
● DDW-PJG-W2X-1	White	120	1400.0	2240.0	2850.0

● Not for new design

NOTE

1. All part number above comes in a quantity of 2000 units per reel.
2. Luminous intensity is measured with an accuracy of ± 11%.
3. Color binning is carried for all units as per the color binning table. Only one color group is allowed for each reel.
4. InGaN wavelength is very sensitive to drive current. Operating at lower current is not recommended and may yield unpredictable performance. Current pushing should be used for dimming purposes.

Electrical Characteristics at Tj=25°C

Part Number	Vf @ If = 20 mA			Vr @ Ir = 10 µA
	Min. (V)	Typ. (V)	Max. (V)	Min. (V)
DDW-PJG	2.8	3.2	3.8	5.0

Forward Voltage, Vf is measured with an accuracy of ± 0.1 V.

Absolute Maximum Ratings

	Maximum Value	Unit
DC forward current	30	mA
Peak pulse current; (tp ≤ 10µs, Duty cycle = 0.10)	100	mA
Reverse voltage; Ir max = 10µA	5	V
ESD threshold (HBM)	2000	V
LED junction temperature	125	°C
Operating temperature	-40 ... +100	°C
Storage temperature	-40 ... +100	°C
Power dissipation (at room temperature)	80	mW
Thermal resistance		
- Junction / ambient, Rth JA	340	K/W
- Junction / solder point, Rth JS	180	K/W
(Mounting on FR4 PCB, pad size ≥ 16 mm ² per pad)		

Characteristics

	Symbol	Part Number	Value	Unit
Temperature coefficient of V_F (typ) $I_F = 20\text{mA}; 0\text{ }^\circ\text{C} \leq T \leq 85\text{ }^\circ\text{C}$	TC_V	DDW-PJG	-2.90	mV / K
Temperature coefficient of I_V (typ) $I_F = 20\text{mA}; 0\text{ }^\circ\text{C} \leq T \leq 85\text{ }^\circ\text{C}$	TC_{IV}	DDW-PJG	-5.30	mcd / K
Temperature coefficient of C_x (typ) $I_F = 20\text{mA}; 0\text{ }^\circ\text{C} \leq T \leq 85\text{ }^\circ\text{C}$	TC_{Cx}	DDW-PJG	-0.0002	
Temperature coefficient of C_y (typ) $I_F = 20\text{mA}; 0\text{ }^\circ\text{C} \leq T \leq 85\text{ }^\circ\text{C}$	TC_{Cy}	DDW-PJG	-0.0002	

DDW, White Color Grouping

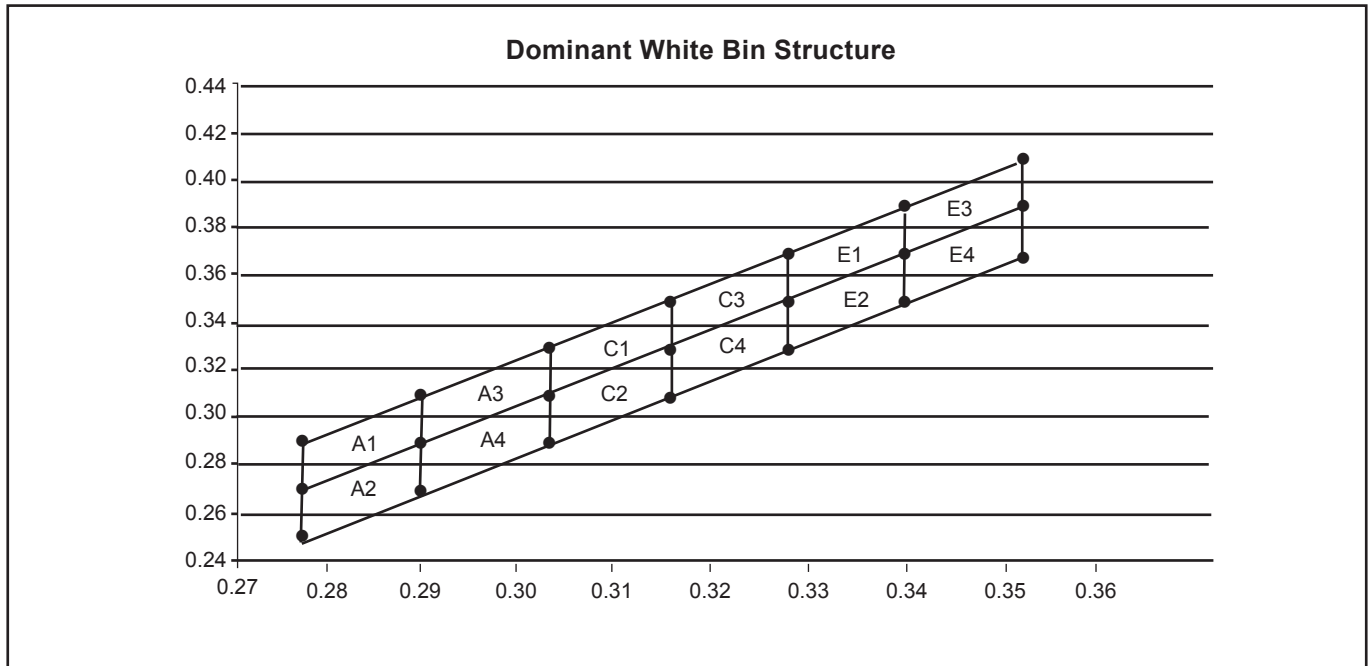

Chromaticity coordinate groups are measured with an accuracy of ± 0.01 .

Bin					
A1	Cx	0.2775	0.2900	0.2900	0.2775
	Cy	0.2732	0.2939	0.3114	0.2907
A2	Cx	0.2775	0.2900	0.2900	0.2775
	Cy	0.2557	0.2764	0.2939	0.2732
A3	Cx	0.2900	0.3025	0.3025	0.2900
	Cy	0.2939	0.3146	0.3321	0.3114
A4	Cx	0.2900	0.3025	0.3025	0.2900
	Cy	0.2764	0.2971	0.3146	0.2939
C1	Cx	0.3025	0.3150	0.3150	0.3025
	Cy	0.3146	0.3354	0.3529	0.3321
C2	Cx	0.3025	0.3150	0.3150	0.3025
	Cy	0.2971	0.3179	0.3354	0.3146
C3	Cx	0.3150	0.3275	0.3275	0.3150
	Cy	0.3354	0.3561	0.3736	0.3529
C4	Cx	0.3150	0.3275	0.3275	0.3150
	Cy	0.3179	0.3386	0.3561	0.3354

Bin					
E1	Cx	0.3275	0.3400	0.3400	0.3275
	Cy	0.3561	0.3768	0.3943	0.3736
E2	Cx	0.3275	0.3400	0.3400	0.3275
	Cy	0.3386	0.3593	0.3768	0.3561
E3	Cx	0.3400	0.3525	0.3525	0.3400
	Cy	0.3768	0.3975	0.4150	0.3943
E4	Cx	0.3400	0.3525	0.3525	0.3400
	Cy	0.3593	0.3800	0.3975	0.3768

Dominant color coordinate is measured with an accuracy of ± 0.01 .

DDW, White Color Grouping

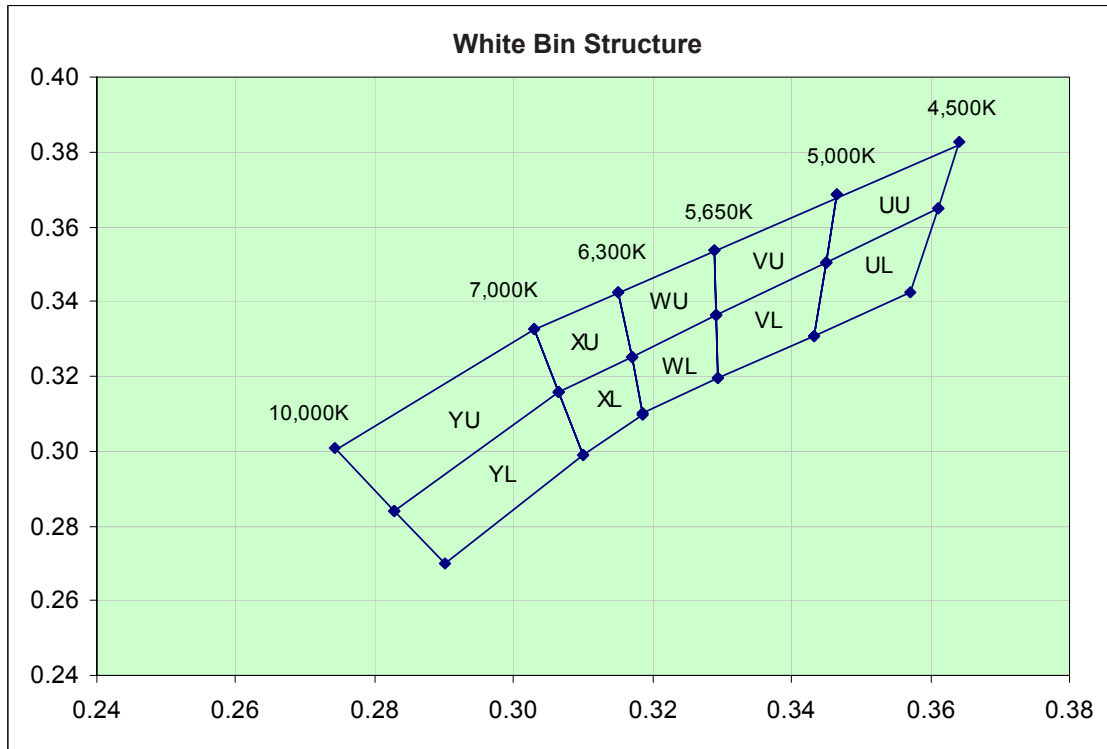

Chromaticity coordinate groups are measured with an accuracy of ± 0.01 .

Bin		1	2	3	4
YU	Cx	0.274	0.283	0.307	0.303
	Cy	0.301	0.284	0.316	0.333
YL	Cx	0.283	0.290	0.310	0.307
	Cy	0.284	0.270	0.299	0.316
XU	Cx	0.303	0.307	0.317	0.315
	Cy	0.333	0.316	0.325	0.343
XL	Cx	0.307	0.310	0.319	0.317
	Cy	0.316	0.299	0.310	0.325
WU	Cx	0.315	0.317	0.329	0.329
	Cy	0.343	0.325	0.336	0.354
WL	Cx	0.317	0.319	0.329	0.329
	Cy	0.325	0.310	0.319	0.336
VU	Cx	0.329	0.329	0.345	0.347
	Cy	0.354	0.336	0.350	0.368
VL	Cx	0.329	0.329	0.343	0.345
	Cy	0.336	0.319	0.331	0.350
UU	Cx	0.347	0.345	0.361	0.364
	Cy	0.368	0.350	0.365	0.383
UL	Cx	0.345	0.343	0.357	0.361
	Cy	0.350	0.331	0.343	0.365

Dominant color coordinate is measured with an accuracy of ± 0.01 .

Luminous Intensity Group at Tj=25°C

Brightness Group	Luminous Intensity IV (mcd)
W1	1125.0...1400.0
W2	1400.0...1800.0
X1	1800.0...2240.0
X2	2240.0...2850.0

Luminous intensity is measured with an accuracy of ± 11%.

Vf Binning (Optional)

Vf Bin @ 20mA	Forward Voltage (V)
0A	2.75 ... 3.05
00	3.05 ... 3.35
01	3.35 ... 3.65
02	3.65 ... 3.95

Forward voltage, Vf is measured with an accuracy of ± 0.1 V.

Please consult sales and marketing for special part number to incorporate Vf binning.

Relative Luminous Intensity Vs Forward Current

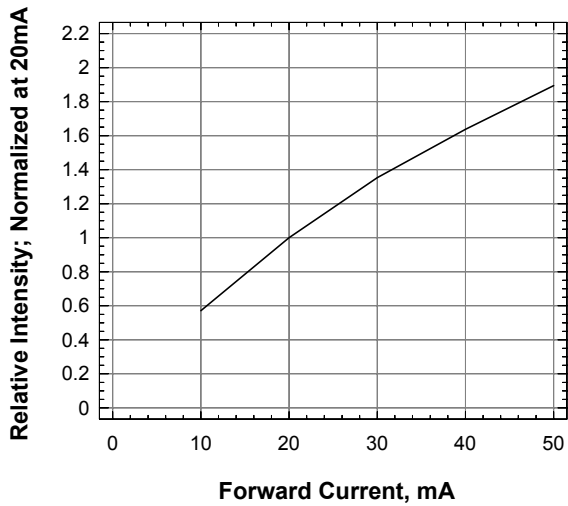

Forward Current Vs Forward Voltage

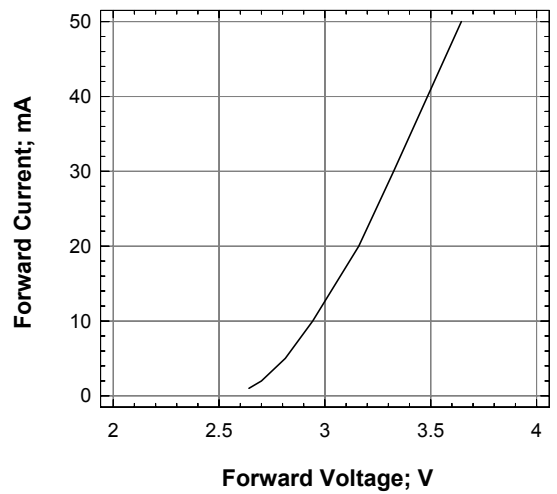

Forward Current Vs Ambient Temperature

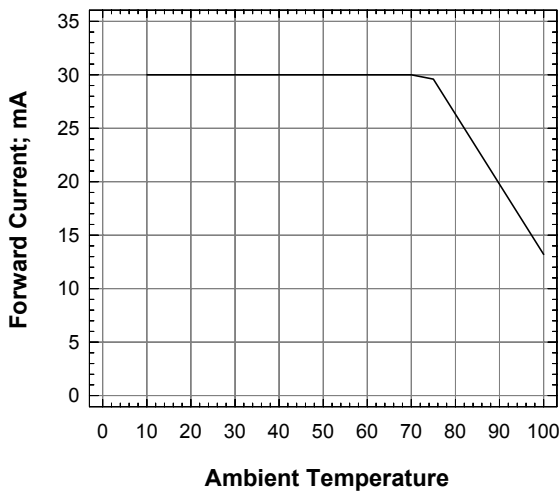

Relative Intensity Vs Wavelength

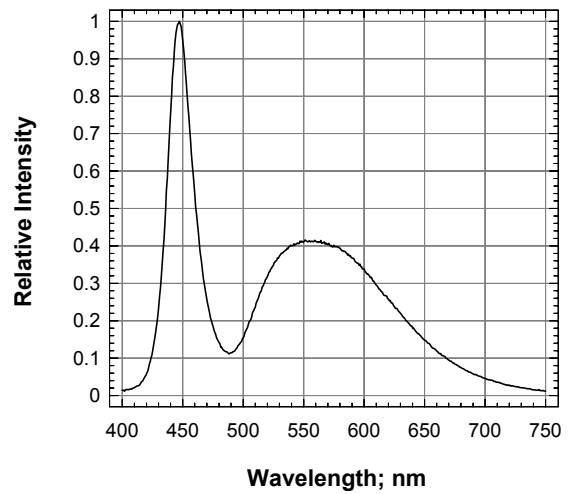

Radiation Pattern

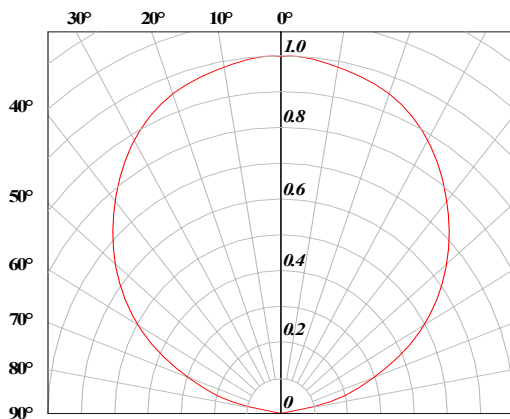

DomiLED™ • InGaN White : DDW-PJG Package Outlines

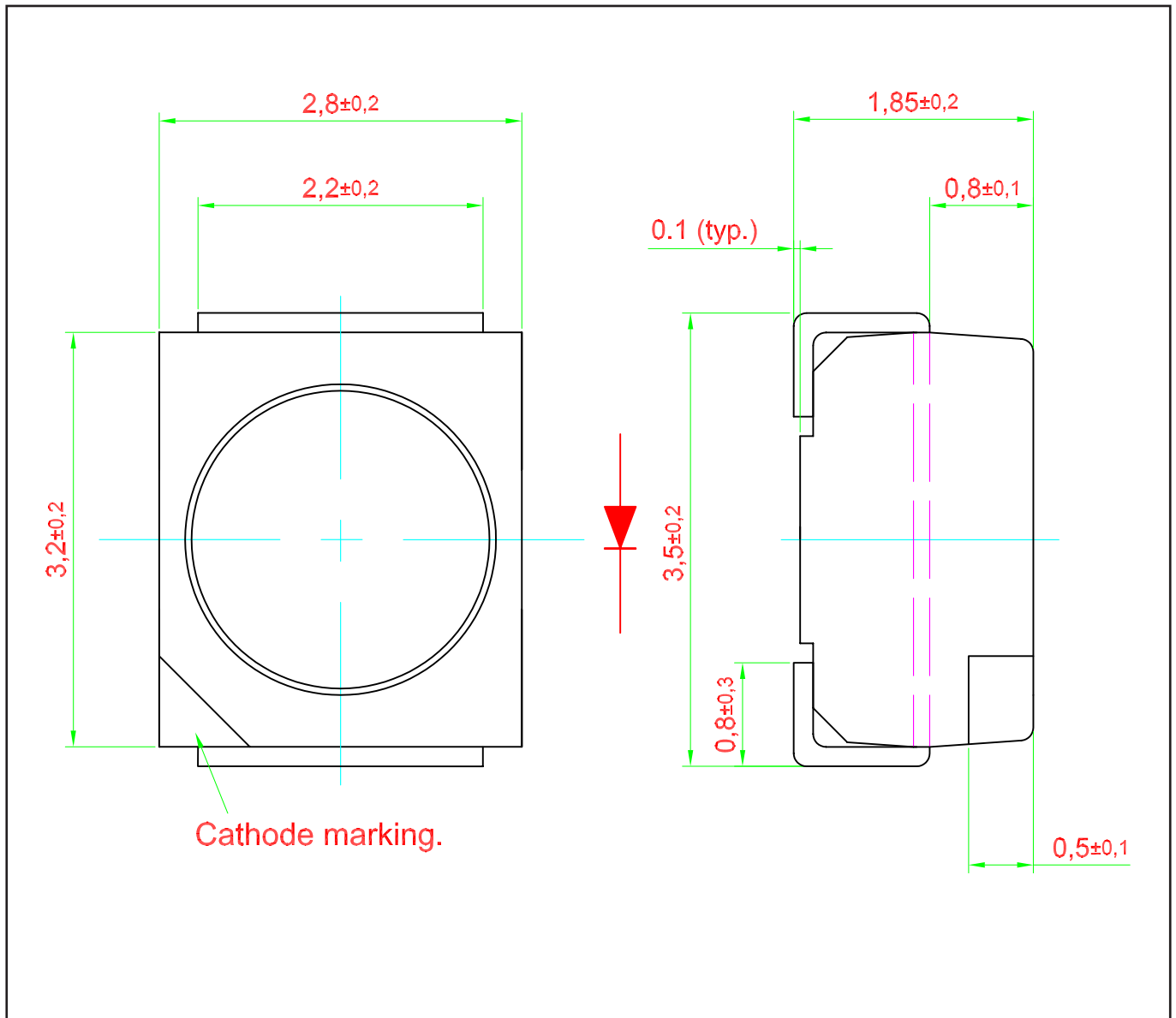

Material

Material	
Lead-frame	Cu Alloy With Ag Plating
Package	High Temperature Resistant Plastic, PPA
Encapsulant	Silicone Resin
Soldering Leads	Sn-Sn Plating

Recommended Solder Pad

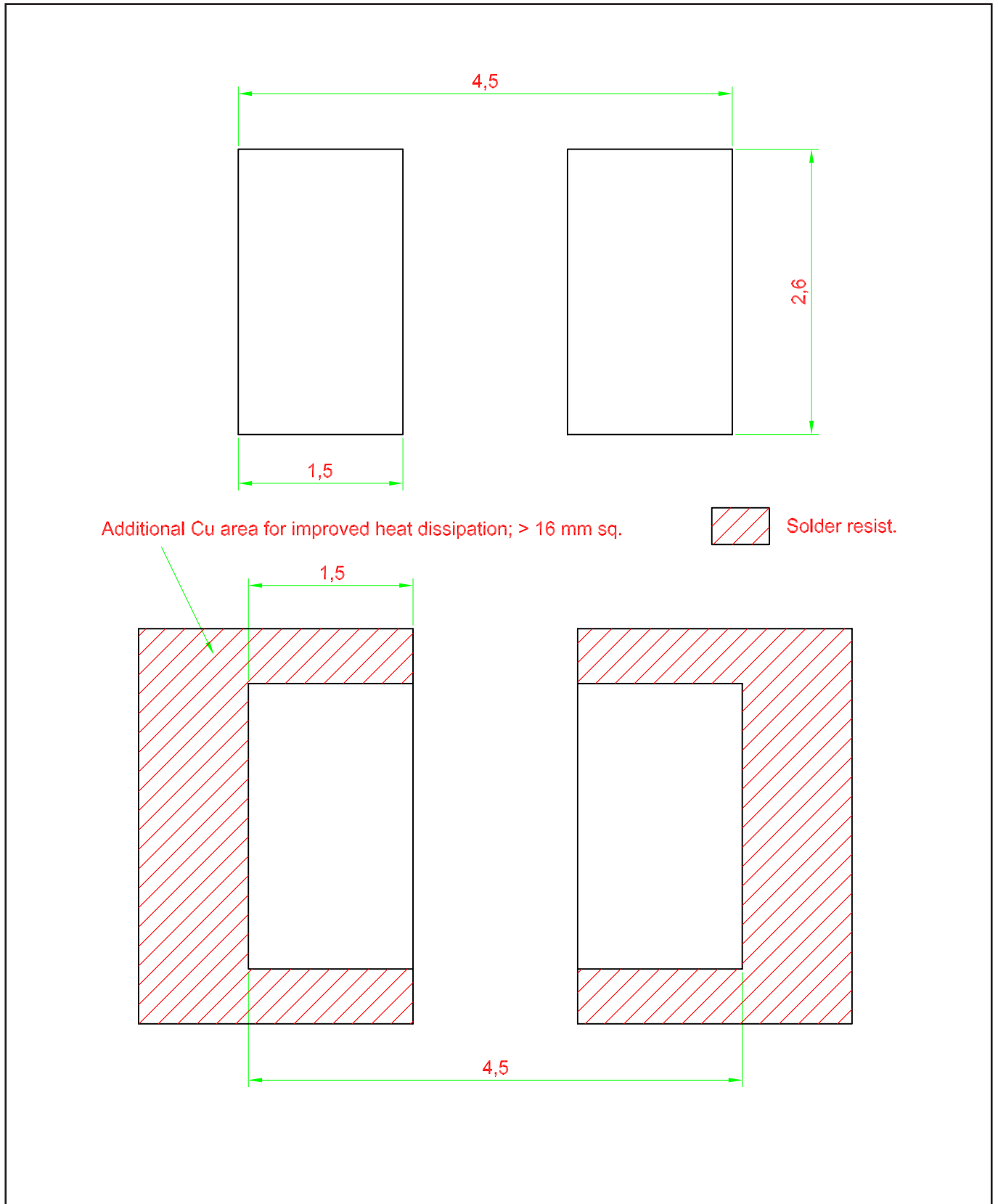

Taping and orientation

- Reels come in quantity of 2000 units.
- Reel diameter is 180 mm.

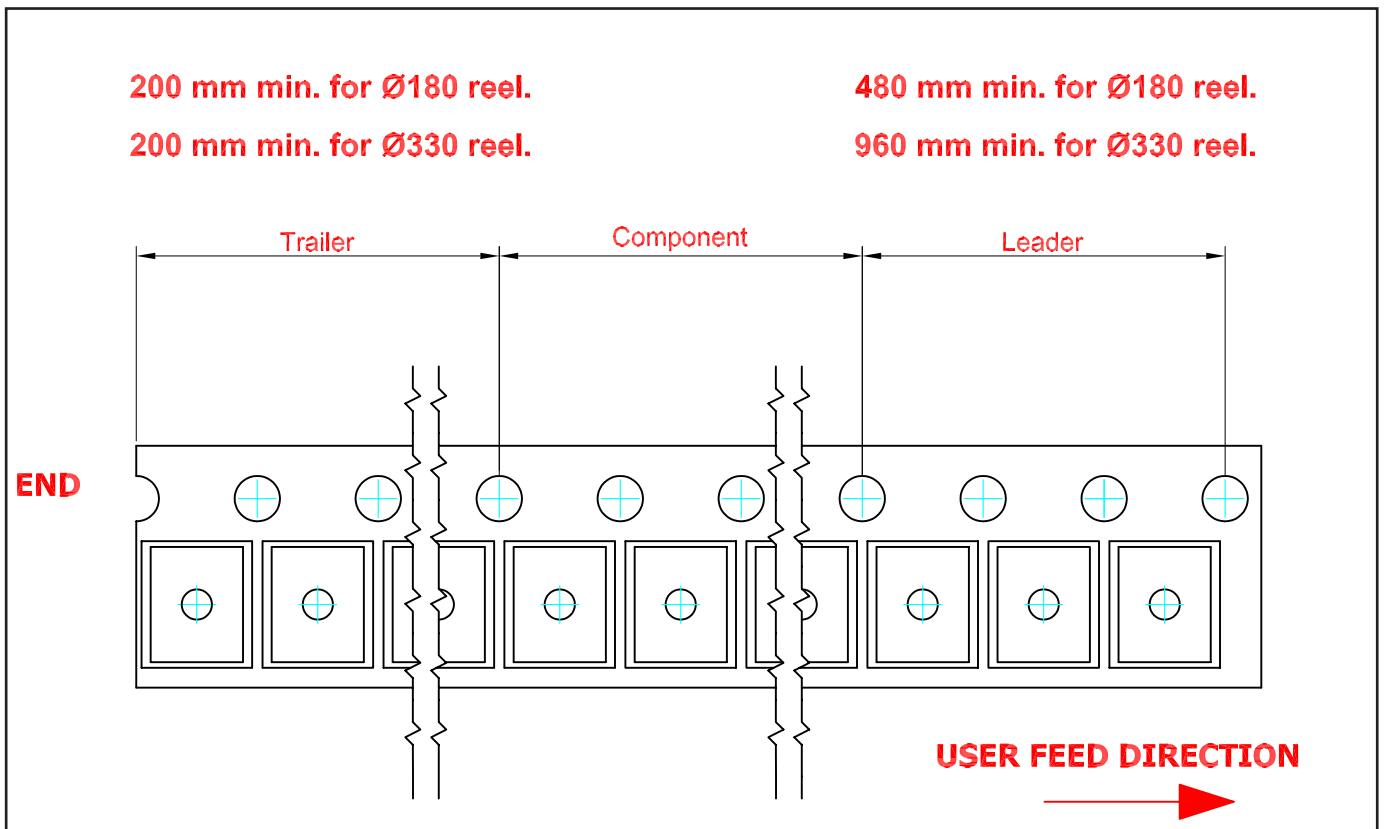
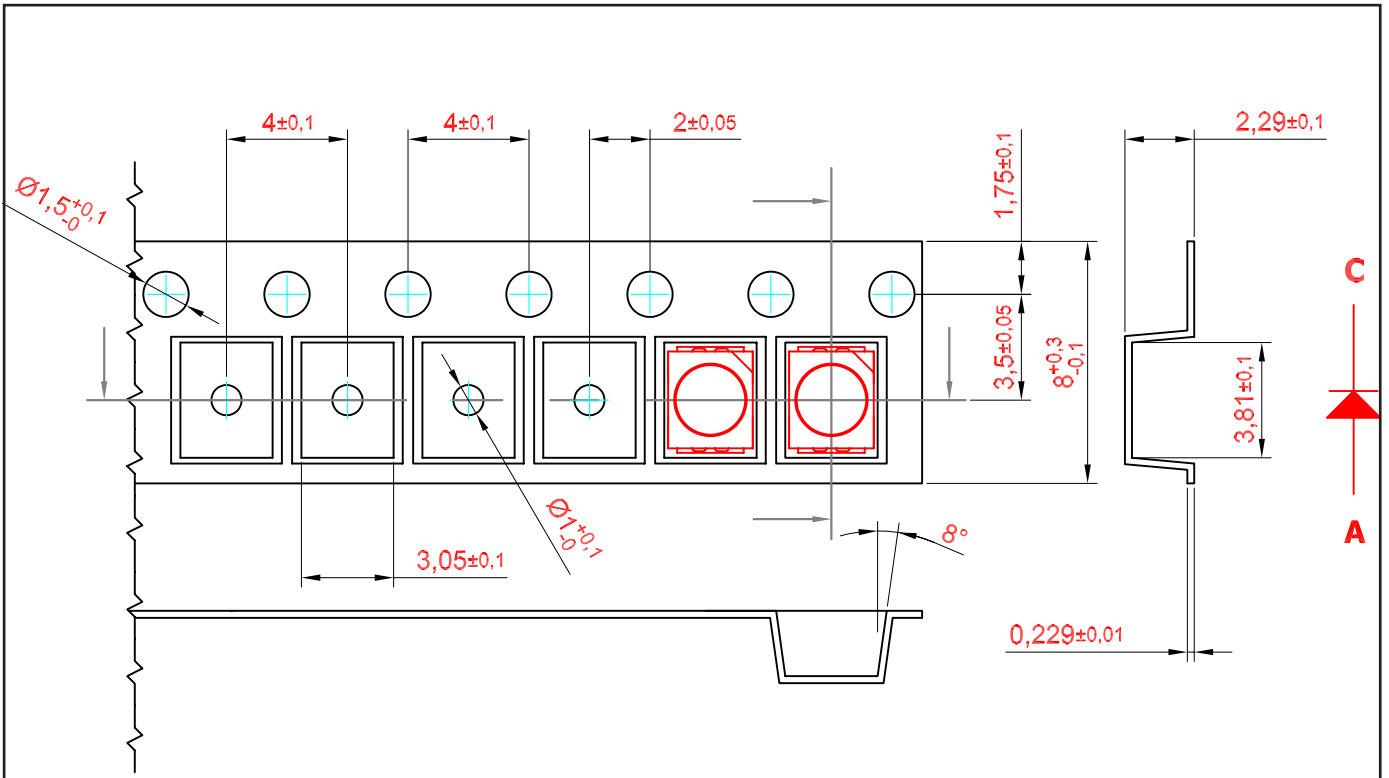

Packaging Specification

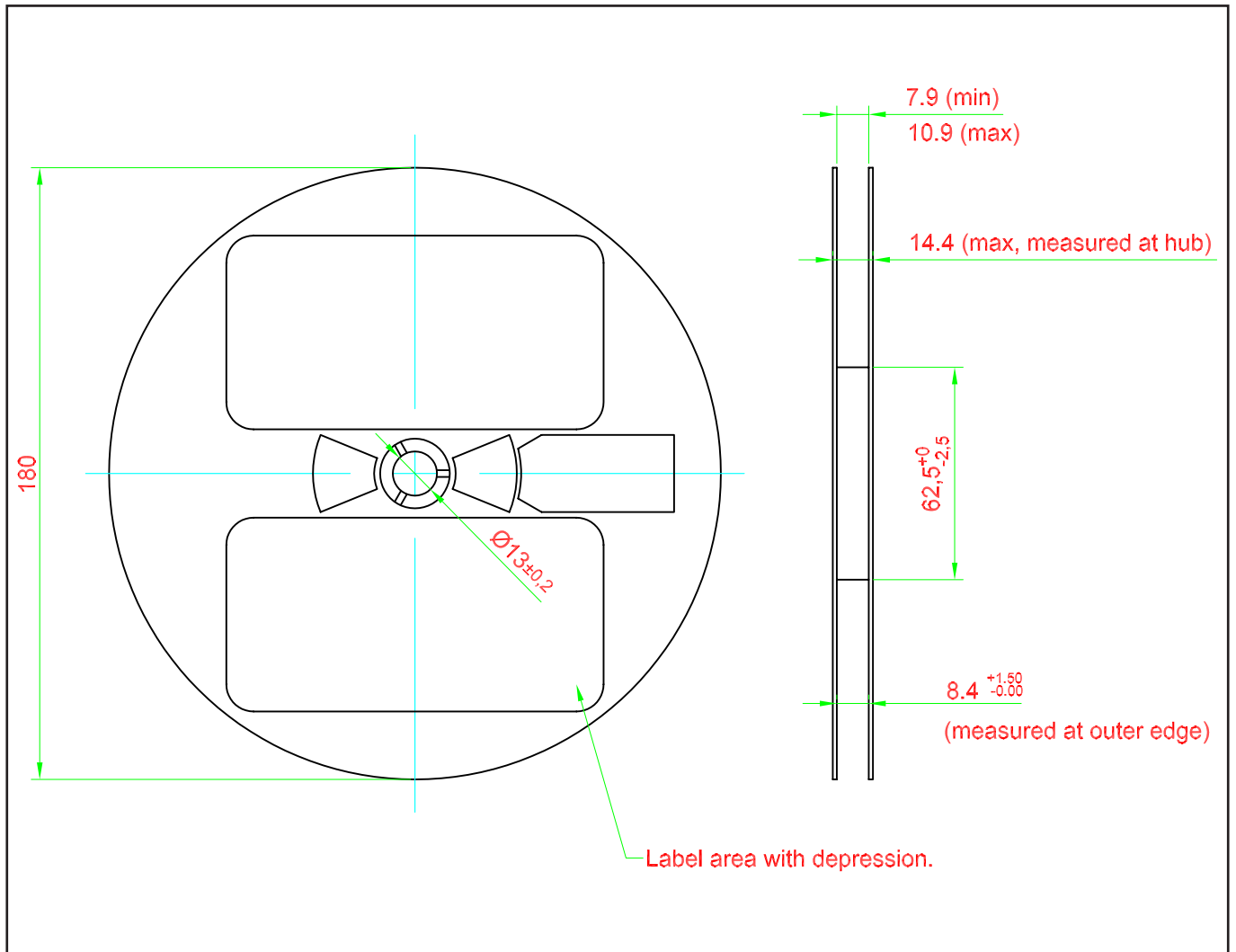

Packaging Specification

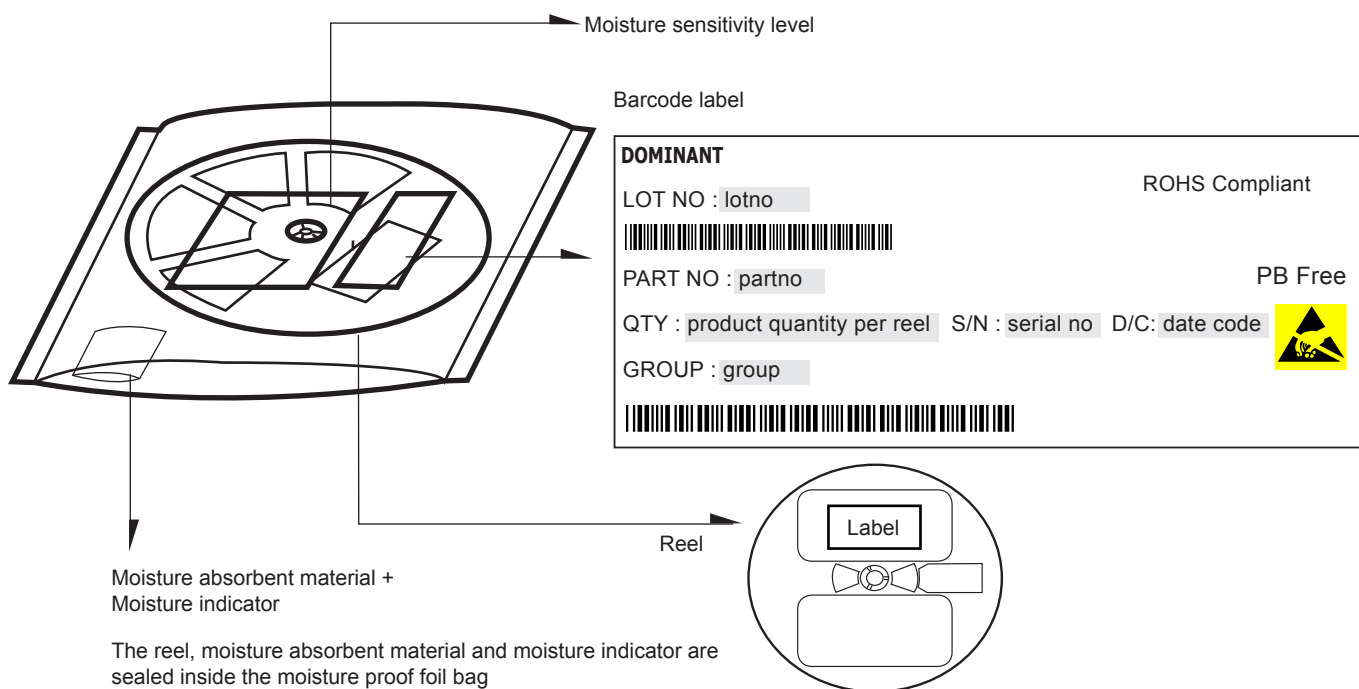

	Average 1pc DomiLED/Multi DomiLED	1 completed bag (2000pcs)
Weight (gram)	0.034	190 ± 10

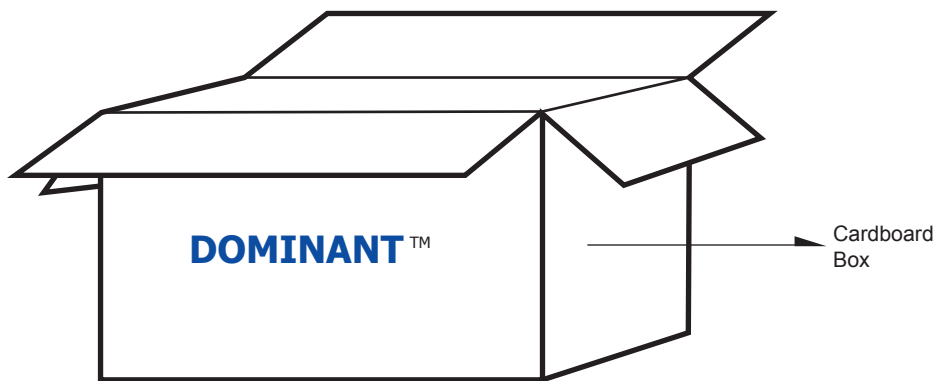

For DomiLED™

Cardboard Box Size	Dimensions (mm)	Empty Box Weight (kg)	Reel / Box	Quantity / Box (pcs)
Small	300 x 250 x 250	0.58	15 reels MAX	30,000 MAX
Large	416 x 516 x 476	1.74	96 reels MAX	192,000 MAX

Recommended Pb-free Soldering Profile

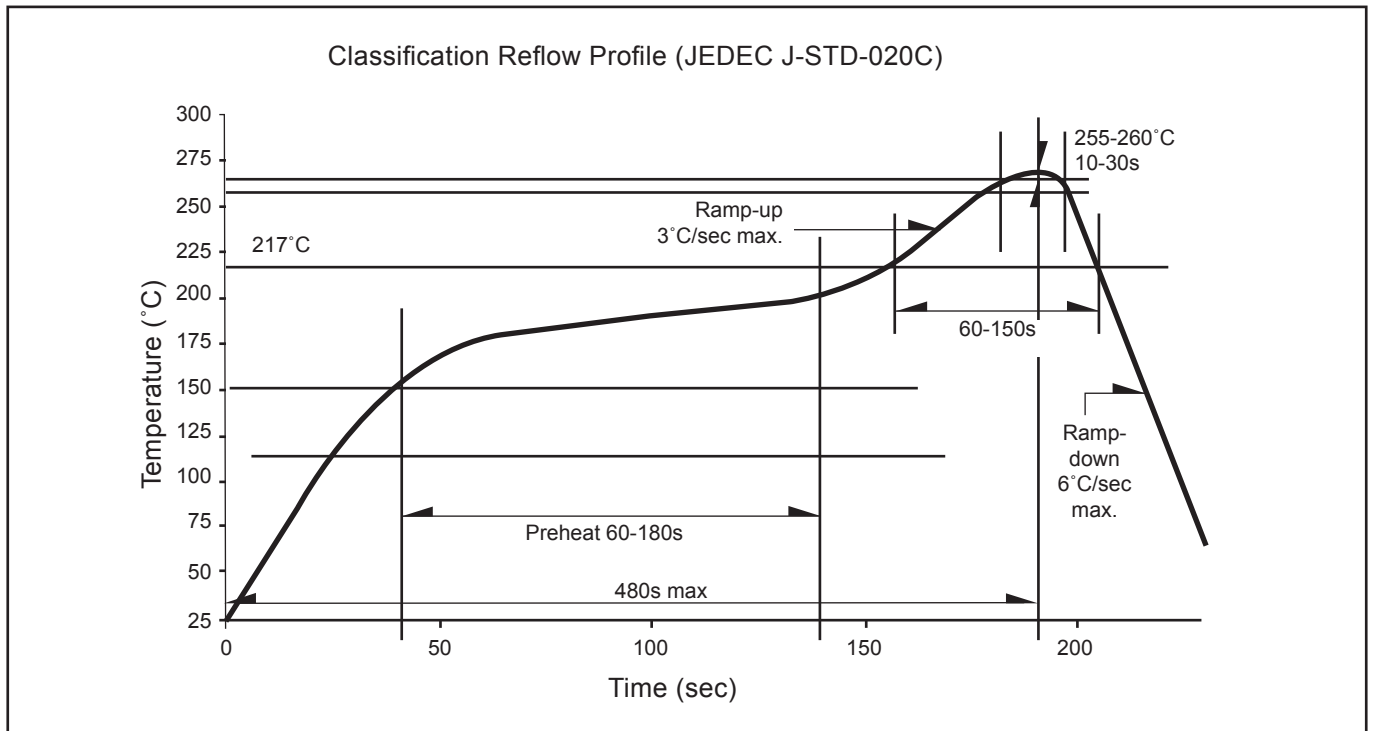

Revision History

Page	Subjects	Date of Modification
-	Initial Release	18 Feb 2009
2	Add Vf binning	8 Jul 2008
2	Update Maximum Forward Current = 30mA	09 Jul 2009
2, 4	- Add new partno: DDW-PJG-W2X-1 - Add CCT Color Bin	27 Jan 2010
3	Add Characteristics	09 Feb 2010
-	Update company name	31 May 2010
2	Not for new design: DDW-PJG-WX1-1, DDW-PJG-W2X-1	10 Dec 2012

NOTE

All the information contained in this document is considered to be reliable at the time of publishing. However, DOMINANT Opto Technologies does not assume any liability arising out of the application or use of any product described herein.

DOMINANT Opto Technologies reserves the right to make changes to any products in order to improve reliability, function or design.

DOMINANT Opto Technologies products are not authorized for use as critical components in life support devices or systems without the express written approval from the Managing Director of DOMINANT Opto Technologies.

About Us

DOMINANT Opto Technologies is a dynamic Malaysian Corporation that is among the world's leading SMT LED Manufacturers. An excellence – driven organization, it offers a comprehensive product range for diverse industries and applications. Featuring an internationally certified quality assurance acclaim, DOMINANT's extra bright LEDs are perfectly suited for various lighting applications in the automotive, consumer and communications as well as industrial sectors. With extensive industry experience and relentless pursuit of innovation, DOMINANT's state-of-art manufacturing, research and testing capabilities have become a trusted and reliable brand across the globe. More information about DOMINANT Opto Technologies can be found on the Internet at <http://www.dominant-semi.com>.

Please contact us for more information:

Head Quarter

DOMINANT Opto Technologies Sdn. Bhd
Lot 6, Batu Berendam, FTZ Phase III, 75350 Melaka, Malaysia.
Tel: +606 283 3566 Fax: +606 283 0566
E-mail: sales@dominant-semi.com

DOMINANT Opto Technologies (Shanghai) Co., Ltd

Rm 305, Hongwell International Plaza No. 1600 Zhong Shan(W) Rd, Xuhui District, 200235 Shanghai, China
Tel: +86 21 5403 5655, Fax: +86 21 5403 6055
E-mail: sales_china@dominant-semi.com

DOMINANT Korea Sales Office

DOMINANT Semiconductors Korea Inc.
#211, Suntech City, 513-15, Sangdaewon 1-Dong, Jungwon-Gu, Seongnam-Si, Gyeonggi-Do, 462-725 Korea.
Tel: +82-31-701-5203 Fax: +82-31-701-5204
E-mail: sales_korea@dominant-semi.com

DOMINANT Europe Sales Office

DOMINANT Semiconductors Europe GmbH
Raiffeisenstr. 38, 74906 Bad Rappenau Germany
Tel: +49 (0) 7264-89010-0 Fax: +49 (0) 7264-89010-29
E-mail: info@dominant-semi.eu

DOMINANT U.S.A Sales Office

25 Rockaway Road, 08833 Lebanon, New Jersey, USA
Tel: +1(908) 439-9930 Cell: +1(908) 343-5810 Fax: +1(908) 439-9929
E-mail: don.wendel@dominant-semi.com

DOMINANT India Sales Office

C-11, Vesanth Business Centre, #86, TTK Road, Alwarpet Chennai - 600 018, India.
Tel: +91-44-42030616 / 516 Fax: +91-44-4920616 Cell: +91-9444 920 537
E-mail: pravat.behera@dominant-semi.com

