

DomiledTM

With the intense colors that seem to glow with energy and its significant brightness, DomiledTM white LED is a highly reliable design device. Its dynamic nature makes it perfect choice for lighthing applications, office and home applications and standard industrial applications.



Features:

- > High brightness surface mount LED.
- > 120° viewing angle.
- > Small package outline (LxWxH) of 3.2 x 2.8 x 1.8mm.
- > Qualified according to JEDEC moisture sensitivity Level 2.
- > Compatible to IR reflow soldering.
- > Environmental friendly; RoHS compliance.



Applications:

- > Automotive: interior applications, eg: switches, telematics, climate control system, dashboard, etc.
- > Consumer Appliances: LCD illumination as in PDAs, LCD TV.
- > Communication: mobile phone flash light, backlights in mobile phone display.
- > Display: full color display video notice board.
- > Industry: channel lighting



Optical Characteristics at Tj=25°C

Part Ordering Number	Color	Viewing Angle°	Luminous Intensity @ IF = 20mA IV (mcd)		
			Min.	Typ.	Max.
● DRF-NJG-V2W-1	Warm White	120	900.0	1400.0	1800.0

- Not for new design

NOTE

1. All part number above comes in a quantity of 2000 units per reel.
2. Luminous intensity is measured with an accuracy of ± 11%.
3. Color binning is carried for all units as per the color binning table. Only one color group is allowed for each reel.

Electrical Characteristics at Tj=25°C

Part Number	Vf @ If = 20 mA			Vr @ Ir = 10 µA
	Min. (V)	Typ. (V)	Max. (V)	Min. (V)
DRF-NJG	2.9	3.4	3.8	5.0

Forward Voltage, Vf is measured with an accuracy of ± 0.1 V.

Absolute Maximum Ratings

	Maximum Value	Unit
DC forward current	20	mA
Peak pulse current; (tp ≤ 10µs, Duty cycle = 0.005)	100	mA
Reverse voltage; Ir max = 10µA	5	V
ESD threshold (HBM)	2000	V
LED junction temperature	125	°C
Operating temperature	-40 ... +100	°C
Storage temperature	-40 ... +100	°C
Power dissipation (at room temperature)	80	mW
Thermal resistance		
- Junction / ambient, Rth JA	380	K/W
- Junction / solder point, Rth JS	280	K/W
(Mounting on FR4 PCB, pad size >= 16 mm ² per pad)		

DRF-NJG, Warm White Color Grouping

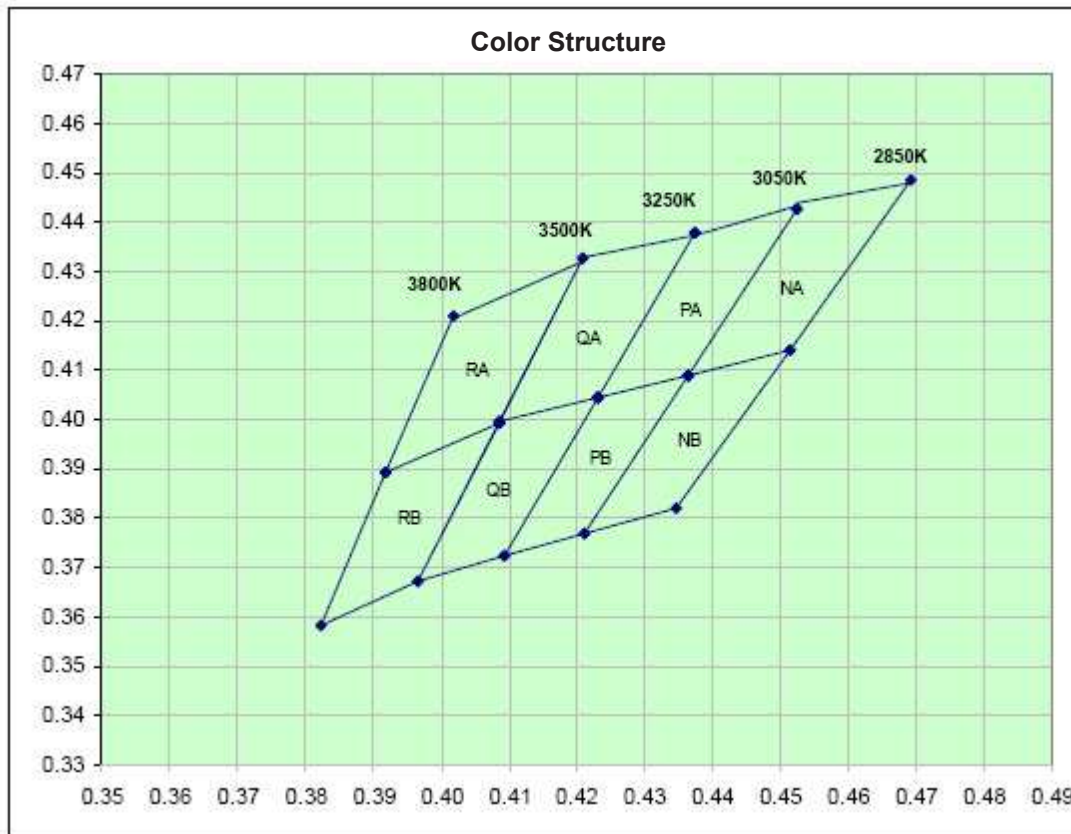

Chromaticity coordinate groups are measured with an accuracy of ± 0.01 .

Bin					
RA	Cx	0.402	0.392	0.409	0.421
	Cy	0.421	0.389	0.399	0.433
RB	Cx	0.392	0.382	0.397	0.409
	Cy	0.389	0.358	0.367	0.399
QA	Cx	0.421	0.409	0.423	0.437
	Cy	0.433	0.400	0.405	0.438
QB	Cx	0.409	0.397	0.409	0.423
	Cy	0.400	0.367	0.372	0.405
PA	Cx	0.437	0.423	0.436	0.452
	Cy	0.438	0.405	0.409	0.443
PB	Cx	0.423	0.409	0.421	0.436
	Cy	0.405	0.372	0.377	0.409
NA	Cx	0.452	0.436	0.451	0.469
	Cy	0.443	0.409	0.414	0.448
NB	Cx	0.436	0.421	0.435	0.451
	Cy	0.409	0.377	0.382	0.414

InGaN wavelength is very sensitive to drive current. Operating at lower current is not recommended and may yield unpredictable performance. Current pulsing should be used for dimming purposes.

Luminous Intensity Group at Tj=25°C

Brightness Group	Luminous Intensity IV (mcd)
V2	900.0...1125.0
W1	1125.0...1400.0
W2	1400.0...1800.0

Luminous intensity is measured with an accuracy of ± 11%.

Relative Luminous Intensity Vs Forward Current

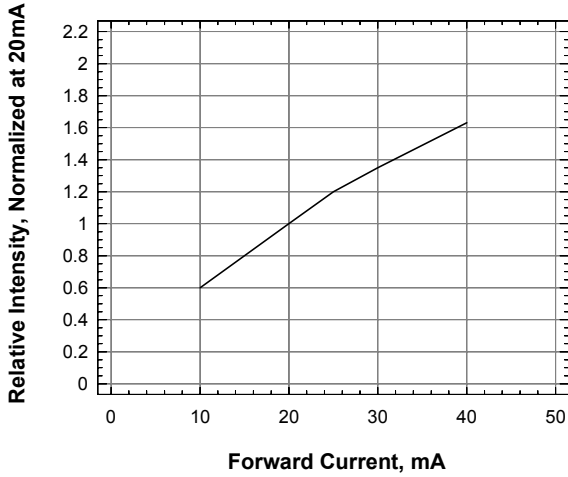

Forward Current Vs Forward Voltage

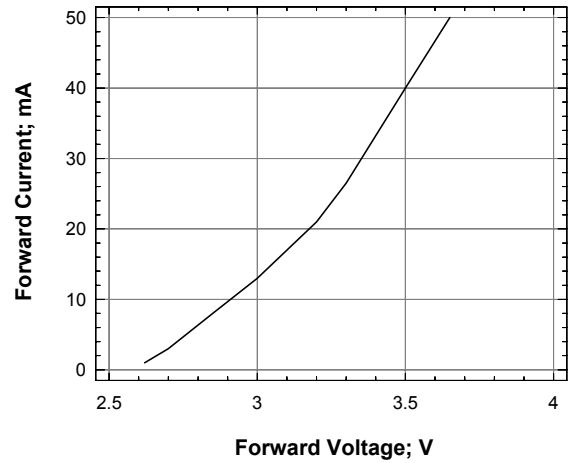

Maximum Forward Current Vs Temperature

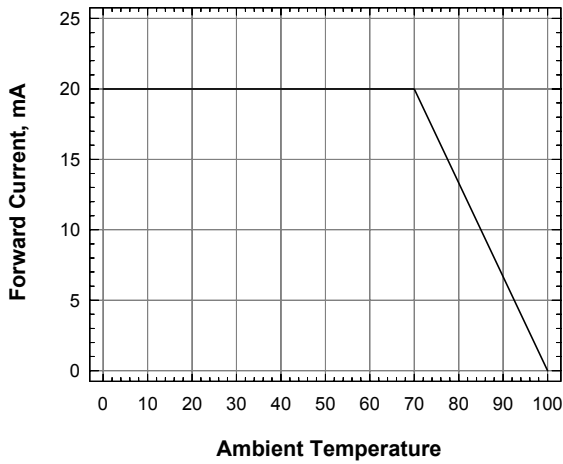

Relative Intensity Vs Wavelength

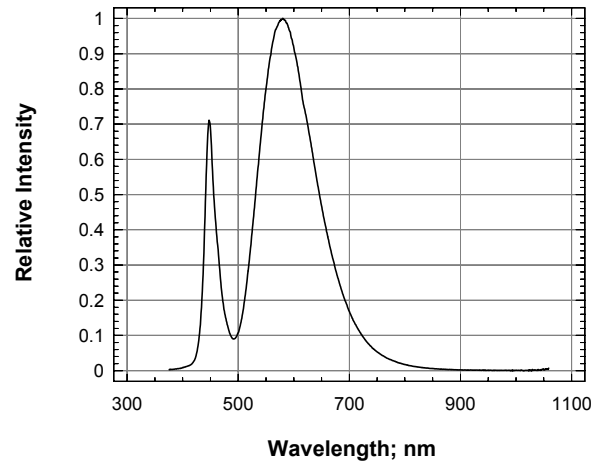

Radiation Pattern

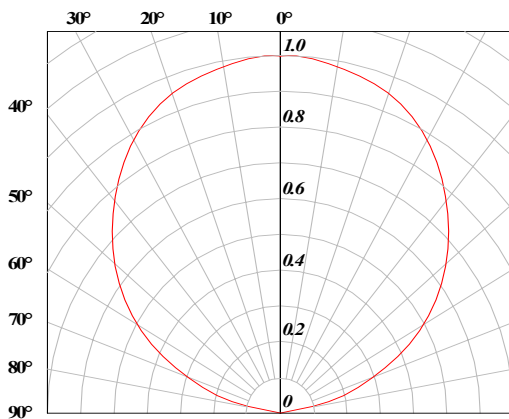

DomiLED™ • InGaN Warm White : DRF-NJG Package Outlines

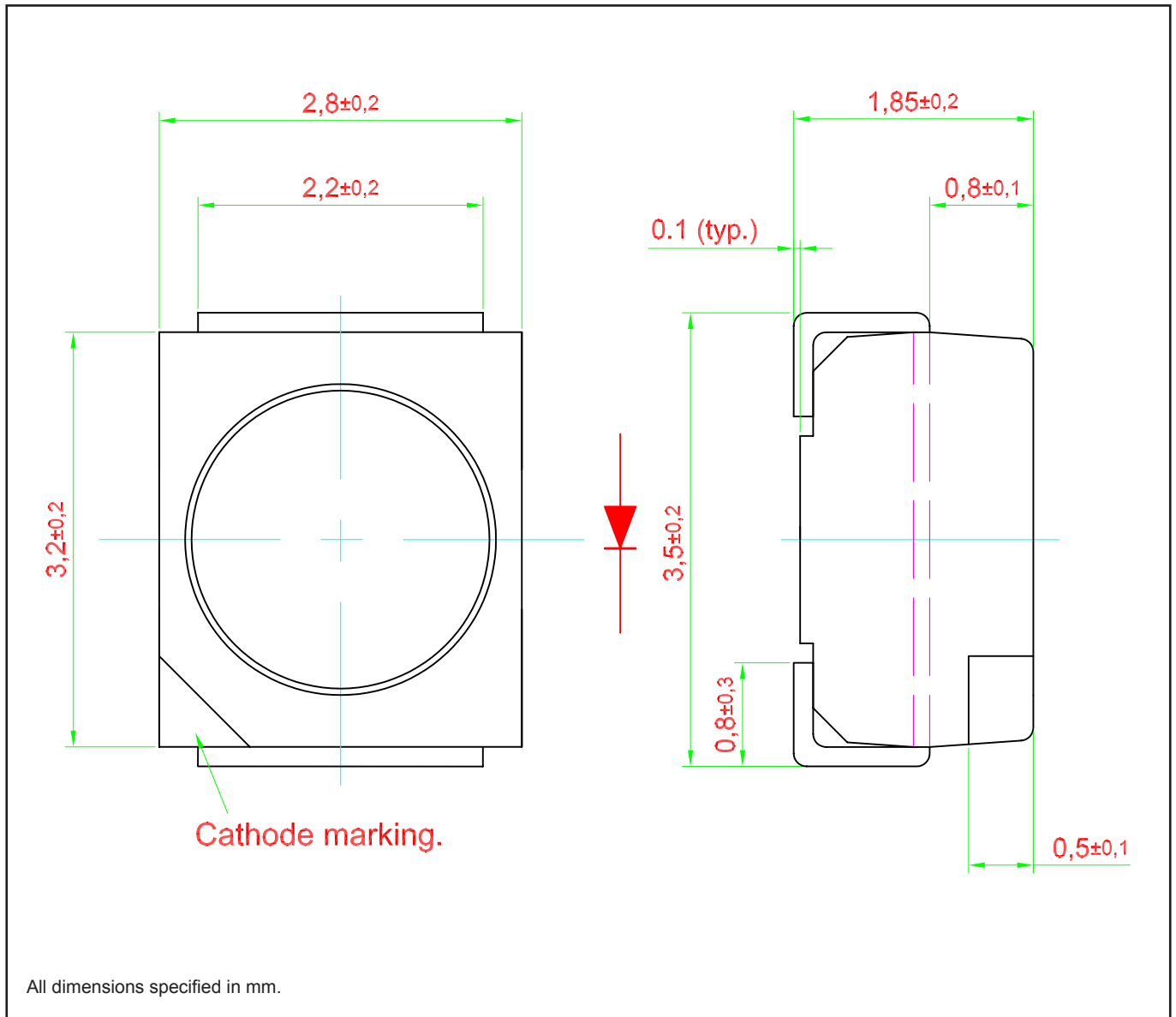

Material

Material	
Lead-frame	Cu Alloy With Ag Plating
Package	High Temperature Resistant Plastic, PPA
Encapsulant	Silicone Resin
Soldering Leads	Sn-Sn Plating

Recommended Solder Pad

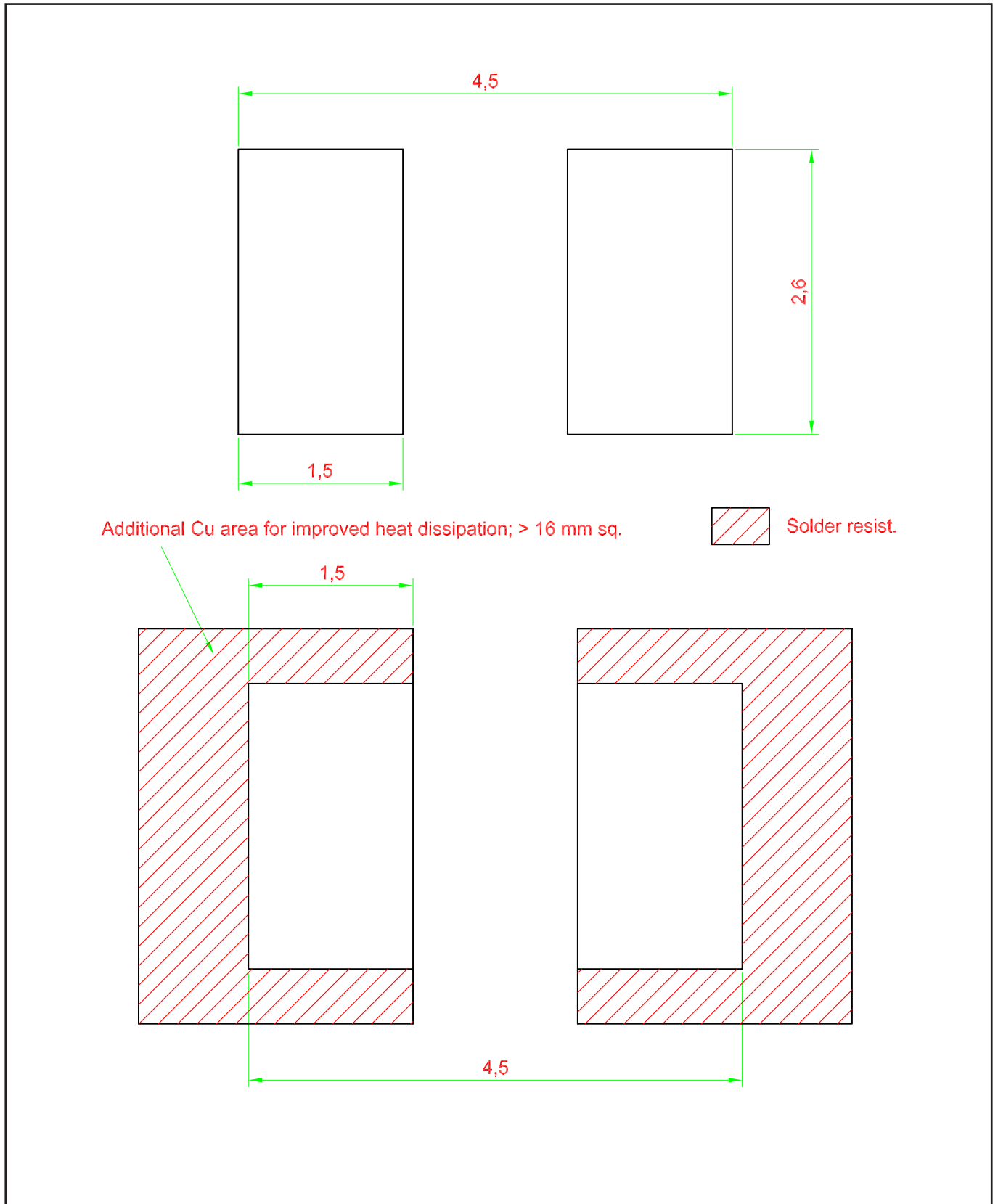

Taping and orientation

- Reels come in quantity of 2000 units.
- Reel diameter is 180 mm.

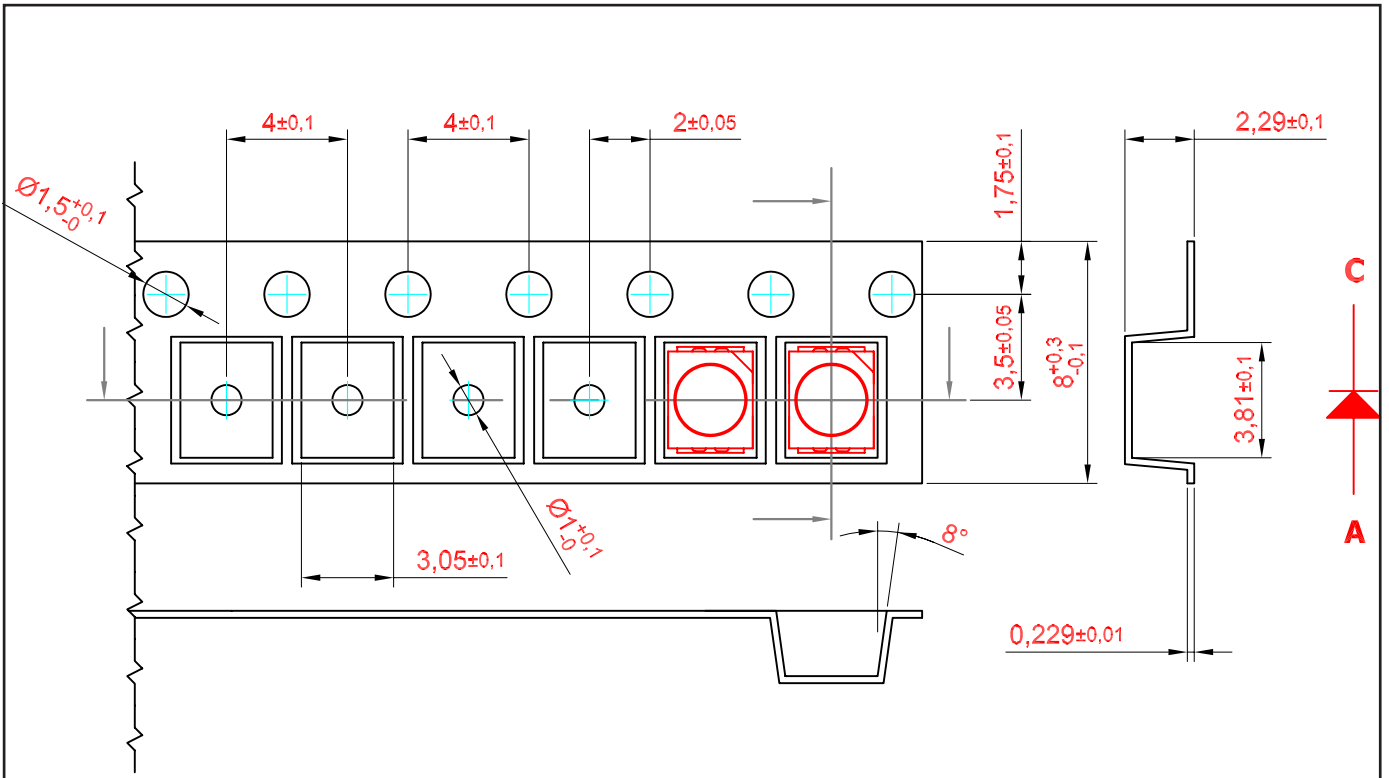

200 mm min. for $\varnothing 180$ reel.
 200 mm min. for $\varnothing 330$ reel.

480 mm min. for $\varnothing 180$ reel.
 960 mm min. for $\varnothing 330$ reel.

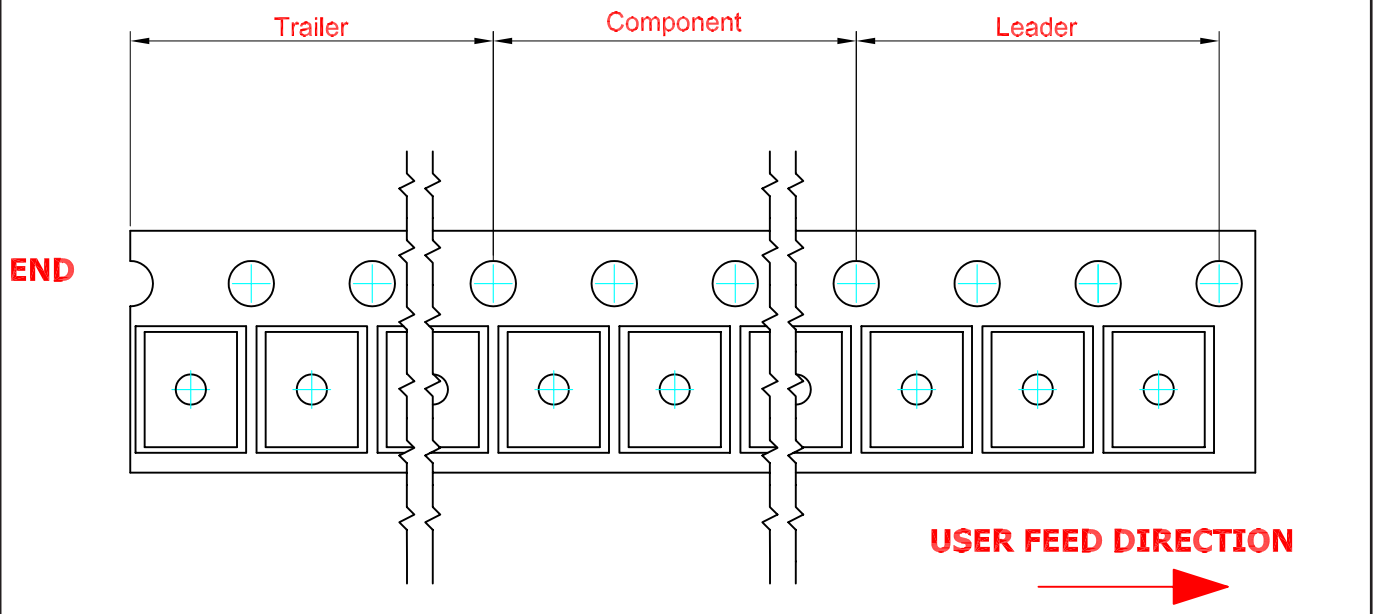

Packaging Specification

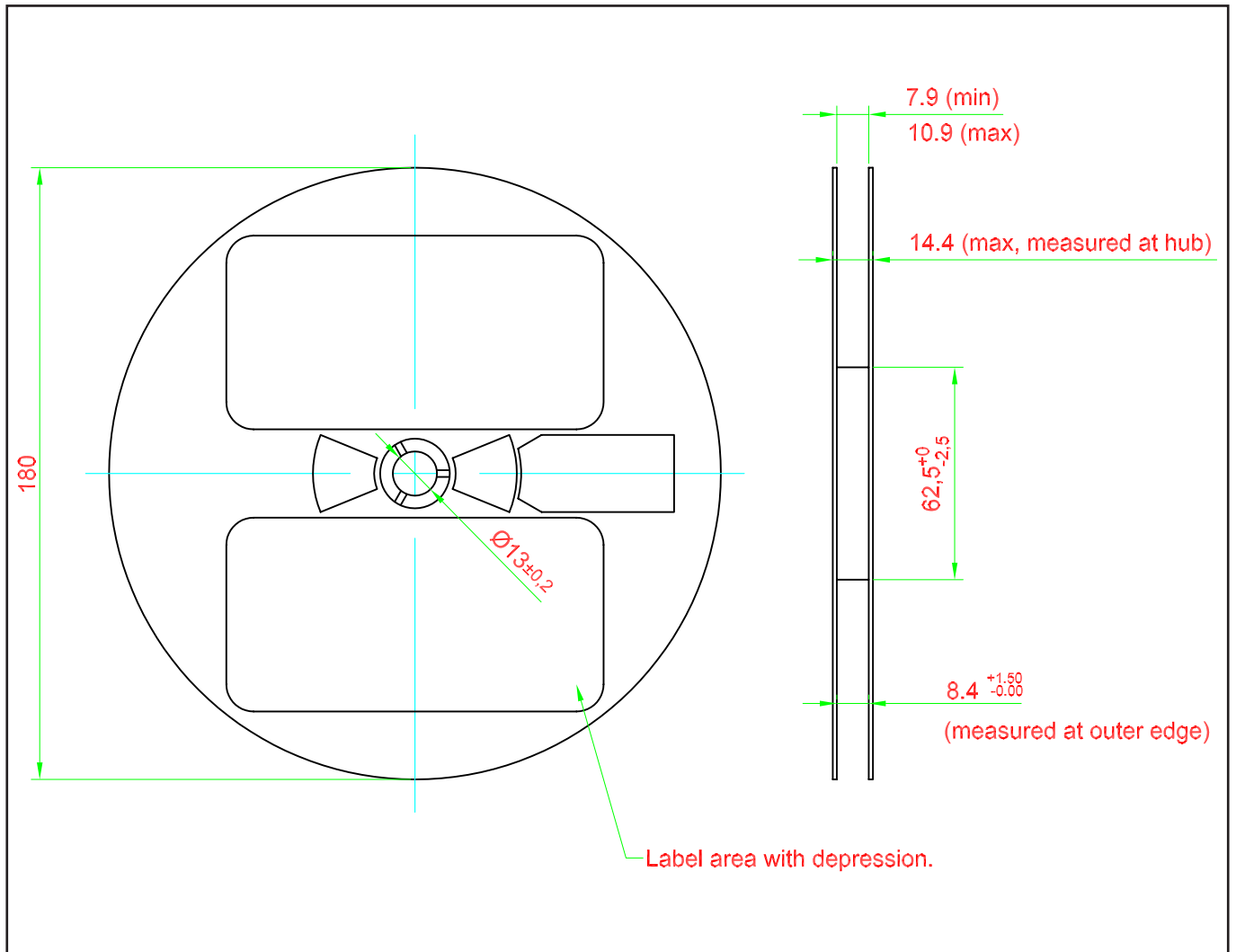

Packaging Specification

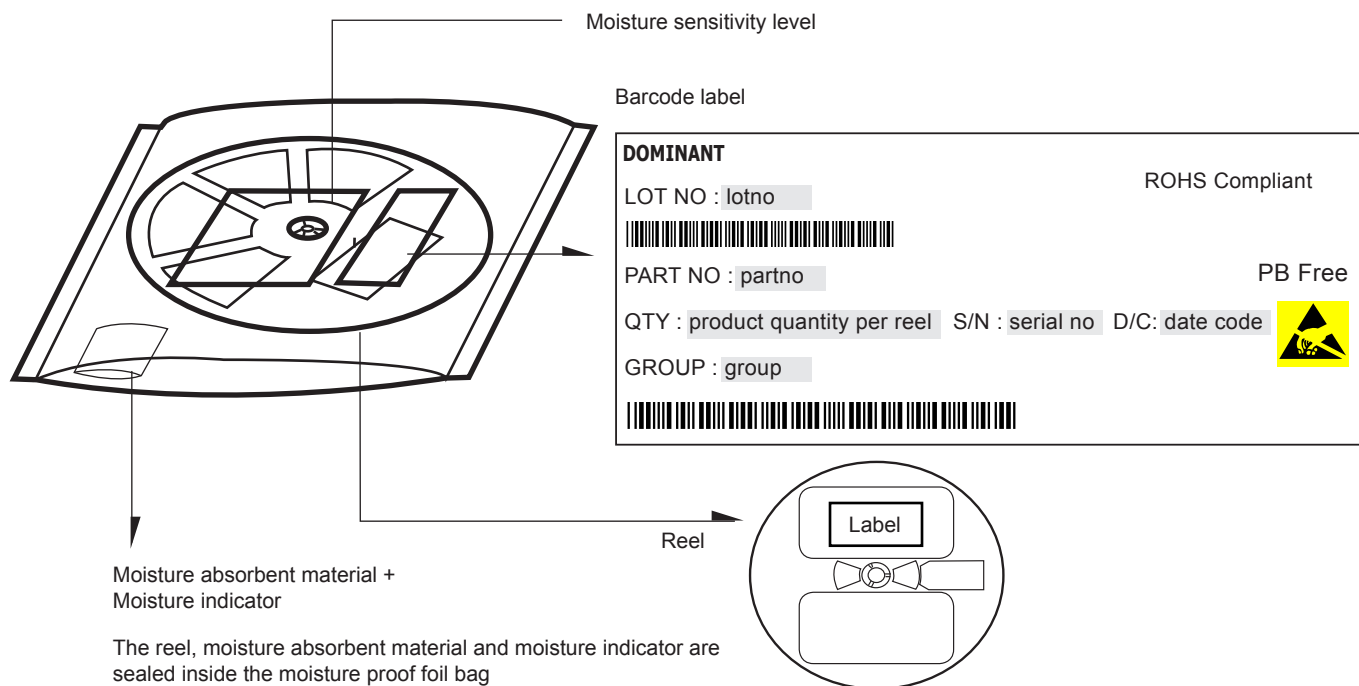

	Average 1pc DomiLED/Multi DomiLED	1 completed bag (2000pcs)
Weight (gram)	0.034	190 ± 10

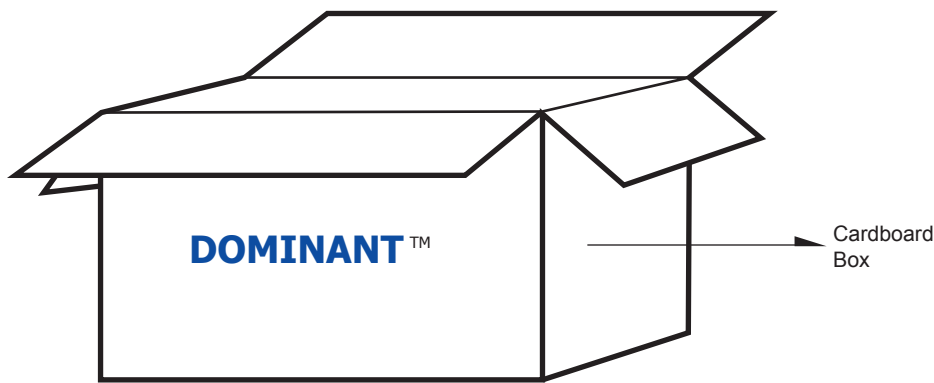

For DomiLED™

Cardboard Box Size	Dimensions (mm)	Empty Box Weight (kg)	Reel / Box	Quantity / Box (pcs)
Small	300 x 250 x 250	0.58	15 reels MAX	30,000 MAX
Large	416 x 516 x 476	1.74	96 reels MAX	192,000 MAX

Recommended Pb-free Soldering Profile

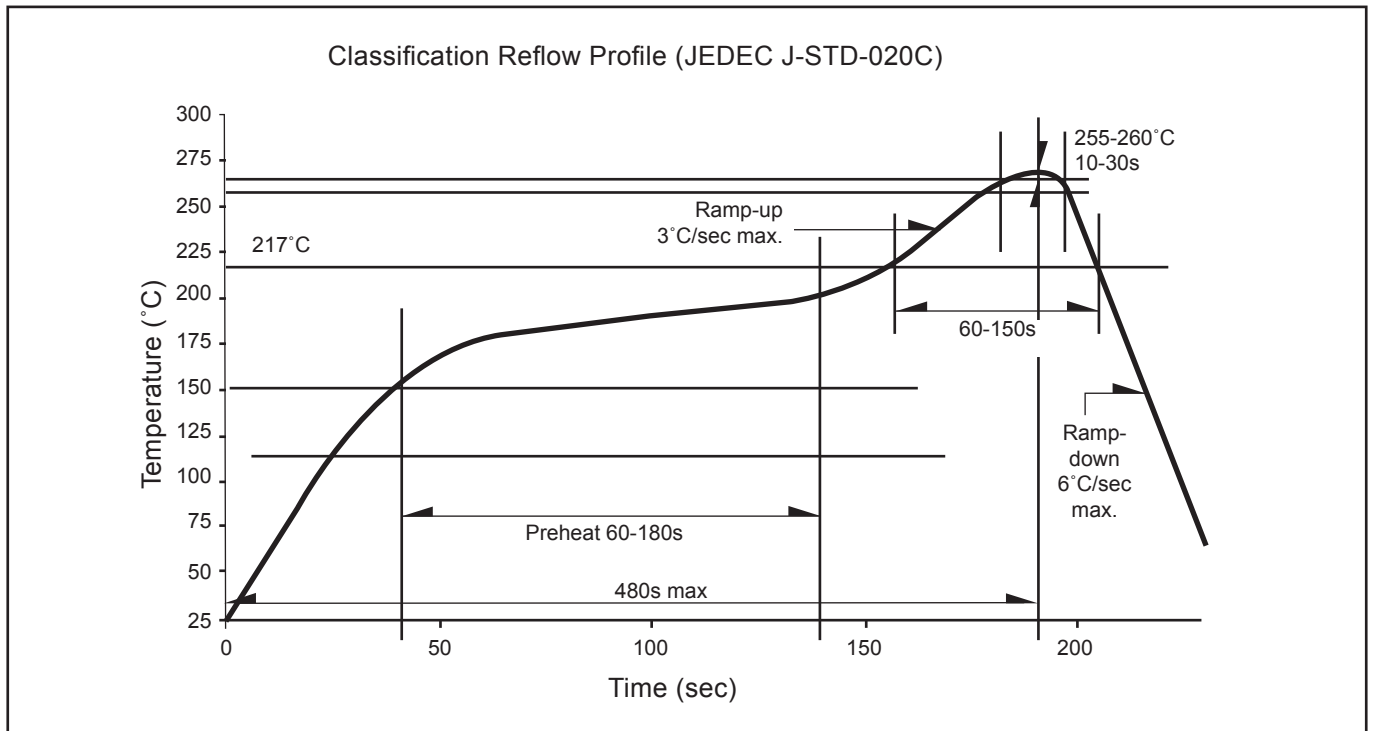

Revision History

Page	Subjects	Date of Modification
-	Initial Release	23 Mar 2009
2	Add Thermal Resistance	03 Dec 2009
-	Update company name	31 May 2010
2	Not for new design: DRF-NJG-V2W-1	10 Dec 2012

NOTE

All the information contained in this document is considered to be reliable at the time of publishing. However, DOMINANT Opto Technologies does not assume any liability arising out of the application or use of any product described herein.

DOMINANT Opto Technologies reserves the right to make changes to any products in order to improve reliability, function or design.

DOMINANT Opto Technologies products are not authorized for use as critical components in life support devices or systems without the express written approval from the Managing Director of DOMINANT Opto Technologies.

About Us

DOMINANT Opto Technologies is a dynamic Malaysian Corporation that is among the world's leading SMT LED Manufacturers. An excellence – driven organization, it offers a comprehensive product range for diverse industries and applications. Featuring an internationally certified quality assurance acclaim, DOMINANT's extra bright LEDs are perfectly suited for various lighting applications in the automotive, consumer and communications as well as industrial sectors. With extensive industry experience and relentless pursuit of innovation, DOMINANT's state-of-art manufacturing, research and testing capabilities have become a trusted and reliable brand across the globe. More information about DOMINANT Opto Technologies can be found on the Internet at <http://www.dominant-semi.com>.

Please contact us for more information:

Head Quarter

DOMINANT Opto Technologies Sdn. Bhd
Lot 6, Batu Berendam, FTZ Phase III, 75350 Melaka, Malaysia.
Tel: +606 283 3566 Fax: +606 283 0566
E-mail: sales@dominant-semi.com

DOMINANT Opto Technologies (Shanghai) Co., Ltd

Rm 305, Hongwell International Plaza No. 1600 Zhong Shan(W) Rd, Xuhui District, 200235 Shanghai, China
Tel: +86 21 5403 5655, Fax: +86 21 5403 6055
E-mail: sales_china@dominant-semi.com

DOMINANT Korea Sales Office

DOMINANT Semiconductors Korea Inc.
#211, Suntech City, 513-15, Sangdaewon 1-Dong, Jungwon-Gu, Seongnam-Si, Gyeonggi-Do, 462-725 Korea.
Tel: +82-31-701-5203 Fax: +82-31-701-5204
E-mail: sales_korea@dominant-semi.com

DOMINANT Europe Sales Office

DOMINANT Semiconductors Europe GmbH
Raiffeisenstr. 38, 74906 Bad Rappenau Germany
Tel: +49 (0) 7264-89010-0 Fax: +49 (0) 7264-89010-29
E-mail: info@dominant-semi.eu

DOMINANT U.S.A Sales Office

25 Rockaway Road, 08833 Lebanon, New Jersey, USA
Tel: +1(908) 439-9930 Cell: +1(908) 343-5810 Fax: +1(908) 439-9929
E-mail: don.wendel@dominant-semi.com

DOMINANT India Sales Office

C-11, Vesanth Business Centre, #86, TTK Road, Alwarpet Chennai - 600 018, India.
Tel: +91-44-42030616 / 516 Fax: +91-44-4920616 Cell: +91-9444 920 537
E-mail: pravat.behera@dominant-semi.com

