



Product Family: [Temperature Variable Attenuators](#)
Part Number Series: [ATV1206C Series](#)



	<p>Construction:</p> <ul style="list-style-type: none"> • High purity Alumina Substrate • Thermo-sensitive thermistor • Ni alloy thin-film resistive elements • 100% matte tin finish terminations (RoHS compliant and Pb Free) 	<p>Features:</p> <ul style="list-style-type: none"> • 1206 English case size • 100mW power rating • Attenuation values between 1 and 16dB • $\pm 0.5\text{dB}$ attenuation tolerance • DC to 3GHz • High volume production suitable for commercial and special applications
--	--	---

The ATV1206C series of temperature variable attenuators utilizes a thermo-sensitive thermistor to control attenuation change over temperature. These are useful in replacing temperature compensation circuits and can simplify auto gain control (AGC) and circuit design in power amplification devices resulting in reduced design time and cost savings.

Product Dimensions:

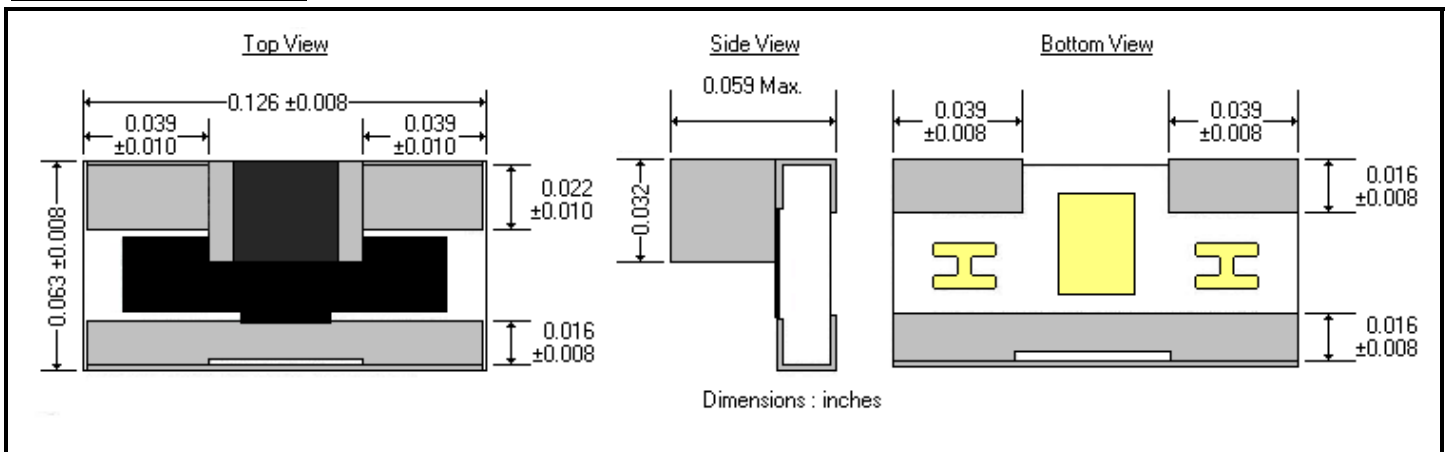

Schematic and Derating Curve:

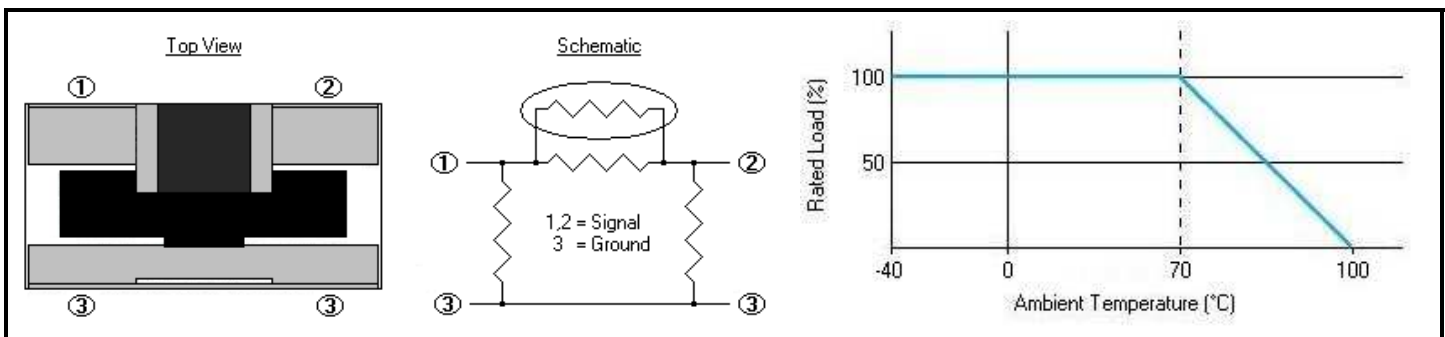

ATV1206 Series Part Numbering: Ex: ATV1206C-03DBN7

Product Designator	English Size	Code	Attenuation Value	Temperature Characteristic
ATV	1206	C = 3 GHz	- 01dB = 1dB, - 02dB = 2dB, - 03dB = 3dB, - 04dB = 4dB, - 05dB = 5dB, - 06dB = 6dB, - 07dB = 7dB, - 08dB = 8dB, - 09dB = 9dB, - 10dB = 10dB - 16dB = 16dB	Refer to electrical tables N1, N2, N3, N4, N5, N6, N7, N8, N9

Electrical Specifications:

Type	ATV1206C
English Size	1206
Metric Size	3216
Attenuation (at 25°C)	1, 2, 3, 4, 5, 6, 7, 8, 9, 10, 16dB
Attenuation Tolerance (at 25°C)	±0.5dB
Impedance	50Ω
VSWR	Less than 1.3
Temperature Characteristic	Each attenuation has either 8 or 9 available temperature characteristics - N1 ~ N9. (Refer to temperature characteristic graphs)
Frequency Range	DC to 3 GHz
Power Rating	100mW (refer to derating curve)
Operating Temperature Range	-40°C to 100°C
Rated Ambient Temperature	70°C
Packaging	Tape & Reel (1,000 pcs/reel)

Reliability Specifications:

Test	Test Method	Specification	
		Attenuation	Impedance
Short Time Overload	Applied voltage: 2.5X rated voltage or 2X maximum operating voltage, whichever is less. Test duration: 5 seconds	±0.1dB	±1%
Load Life	Test Temperature: 70°C Applied voltage: rated voltage Test period: 1000 hours with power cycling as follows: 90 min. power ON/30 min. power OFF,	±0.1dB	±2%
Moisture Load Life	Test Condition: 60°C/90-95% RH Applied voltage: rated voltage Test period: 1000 hours with power cycling as follows: 90 min. power ON/30 min. power OFF	±0.2dB	±2%
Temperature Cycle	Repeat 5 cycles as follows: -40°C(30 min.) / Room temp (3 min) / +100°C(30 min.) / Room temp (3 min)	±0.1dB	±1%
Resistance to Soldering Heat	Solder dip at 260°C for 10 seconds	±0.1dB	±1%
Substrate Bending	Span between fulcrums: 90mm, Bend width: 3mm Substrate: glass epoxy, 1.6mm thickness	±0.1dB	±1%
Solderability	Solder dip at 245°C for 3 seconds	A new uniform coating of solder shall cover a minimum of 95% of immersed surface.	

Tape and Reel Dimensions:

	<table border="1"> <thead> <tr> <th>Symbol</th> <th>Dimensions (mm)</th> </tr> </thead> <tbody> <tr> <td>A</td> <td>2.0 ±0.2</td> </tr> <tr> <td>B</td> <td>3.6 ±0.2</td> </tr> <tr> <td>W</td> <td>8.0 ±0.3</td> </tr> <tr> <td>F</td> <td>3.5 ±0.05</td> </tr> <tr> <td>E</td> <td>1.75 ±0.1</td> </tr> <tr> <td>T</td> <td>2.5 or less</td> </tr> </tbody> </table>	Symbol	Dimensions (mm)	A	2.0 ±0.2	B	3.6 ±0.2	W	8.0 ±0.3	F	3.5 ±0.05	E	1.75 ±0.1	T	2.5 or less	<table border="1"> <thead> <tr> <th>Symbol</th> <th>Dimensions (mm)</th> </tr> </thead> <tbody> <tr> <td>P₀</td> <td>4.0 ±0.1</td> </tr> <tr> <td>P₁</td> <td>4.0 ±0.1</td> </tr> <tr> <td>P₂</td> <td>2.0 ±0.05</td> </tr> <tr> <td>D₀</td> <td>1.55 ±0.05</td> </tr> <tr> <td>t</td> <td>0.3 or less</td> </tr> </tbody> </table>	Symbol	Dimensions (mm)	P ₀	4.0 ±0.1	P ₁	4.0 ±0.1	P ₂	2.0 ±0.05	D ₀	1.55 ±0.05	t	0.3 or less
	Symbol	Dimensions (mm)																										
A	2.0 ±0.2																											
B	3.6 ±0.2																											
W	8.0 ±0.3																											
F	3.5 ±0.05																											
E	1.75 ±0.1																											
T	2.5 or less																											
Symbol	Dimensions (mm)																											
P ₀	4.0 ±0.1																											
P ₁	4.0 ±0.1																											
P ₂	2.0 ±0.05																											
D ₀	1.55 ±0.05																											
t	0.3 or less																											

Reel Dimensions:

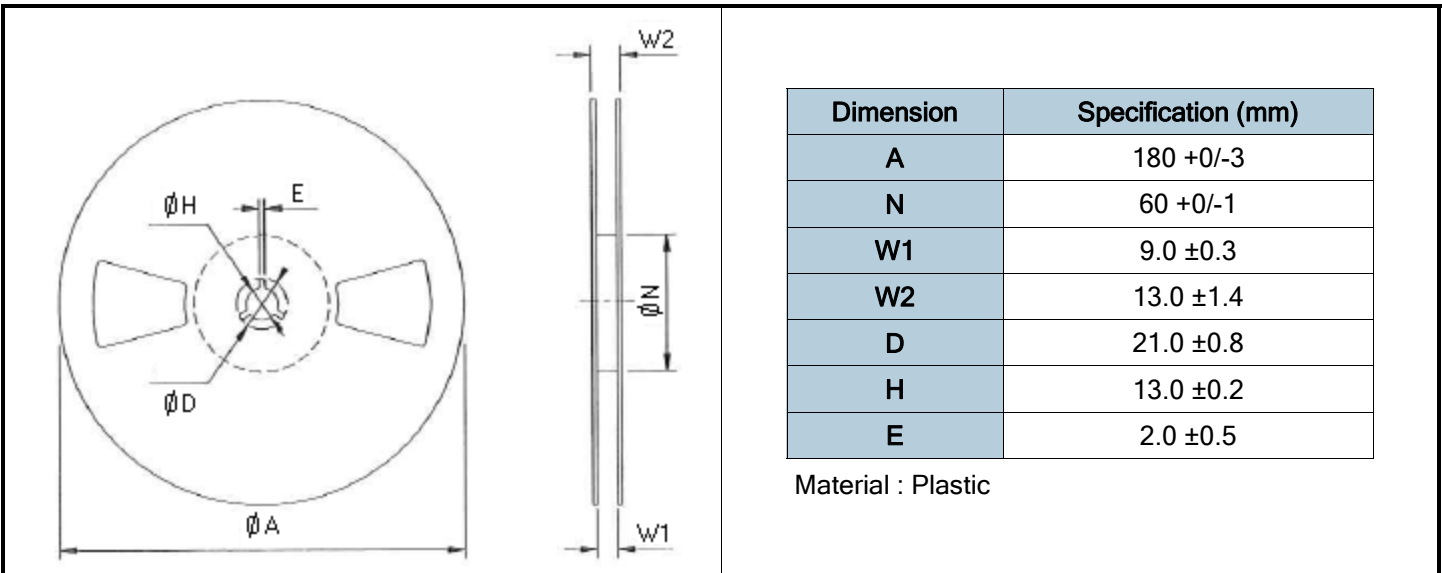

Taping Orientation:

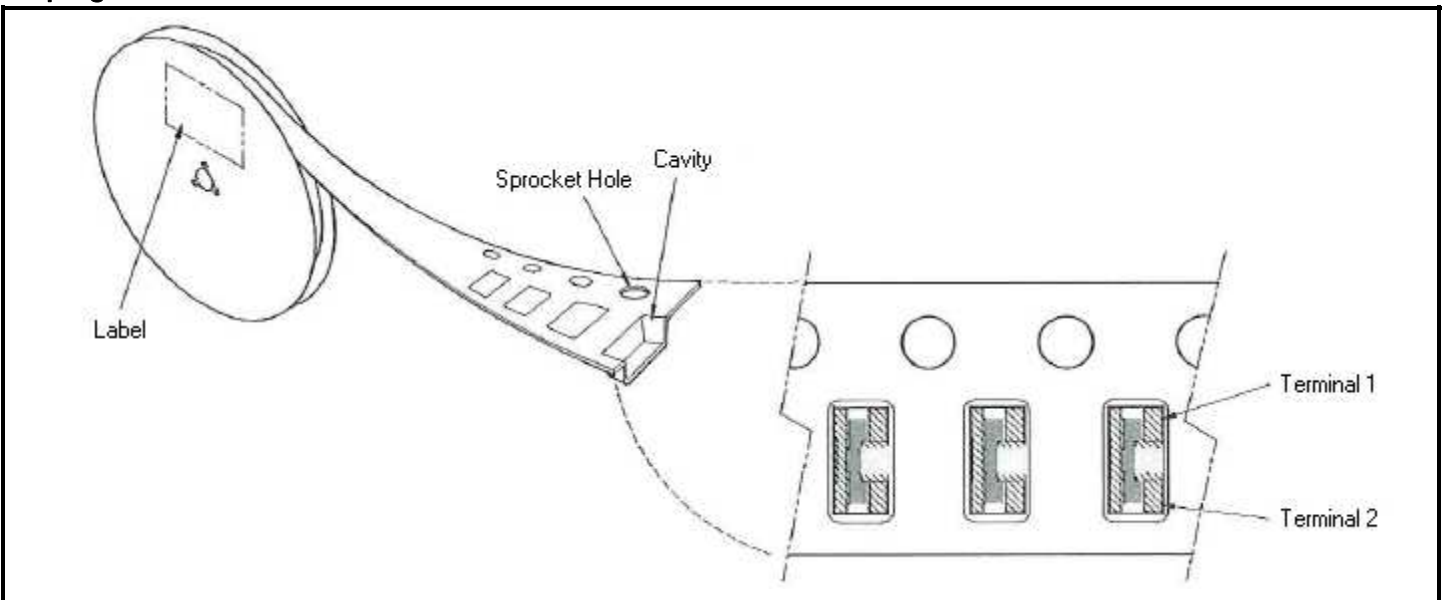

Recommended Reflow:

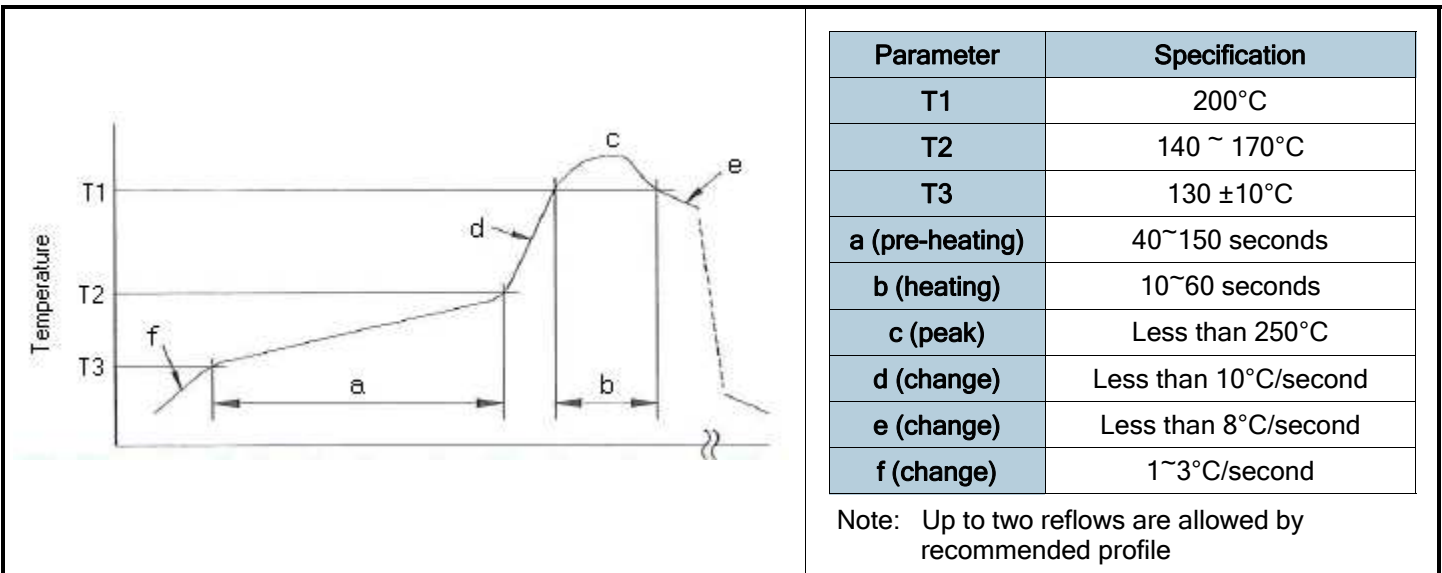

Temperature Characteristics - 1dB Product:

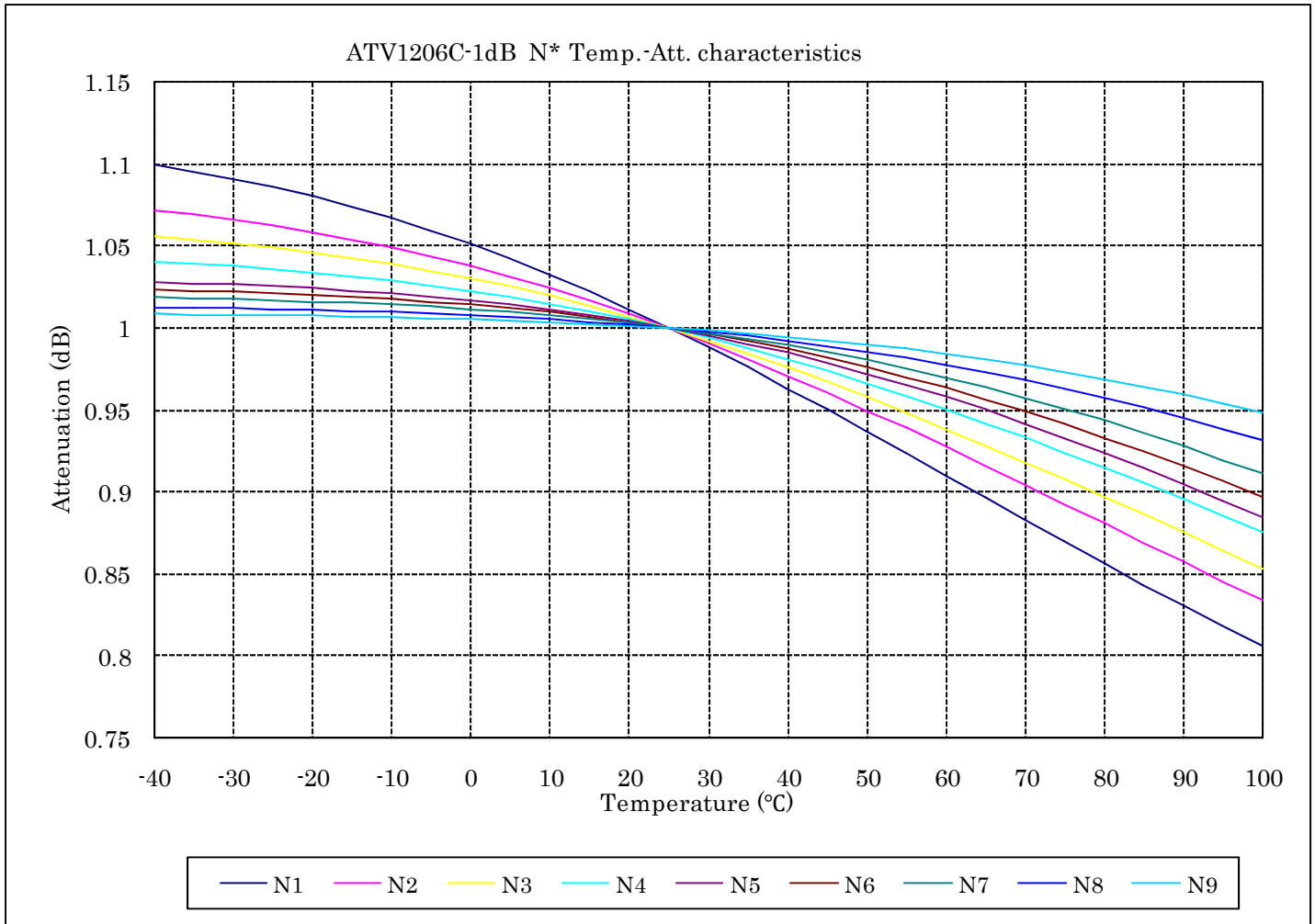

Attenuation at Temperatures Throughout Operating Temperature Range (1dB Product)

Temperature (°C)	N1	N2	N3	N4	N5	N6	N7	N8	N9
-40	1.099	1.072	1.056	1.041	1.028	1.023	1.018	1.013	1.008
-35	1.095	1.069	1.054	1.039	1.027	1.023	1.018	1.012	1.008
-30	1.091	1.066	1.052	1.038	1.026	1.022	1.017	1.012	1.008
-25	1.086	1.063	1.049	1.036	1.025	1.021	1.017	1.012	1.008
-20	1.080	1.059	1.046	1.034	1.024	1.020	1.016	1.011	1.007
-15	1.074	1.054	1.043	1.032	1.023	1.019	1.015	1.010	1.007
-10	1.067	1.049	1.039	1.029	1.021	1.018	1.014	1.010	1.007
-5	1.059	1.044	1.035	1.026	1.019	1.016	1.013	1.009	1.006
0	1.051	1.038	1.030	1.023	1.017	1.014	1.011	1.008	1.005
5	1.042	1.031	1.025	1.019	1.014	1.012	1.010	1.007	1.005
10	1.032	1.024	1.020	1.015	1.011	1.009	1.008	1.005	1.004
15	1.022	1.017	1.014	1.010	1.008	1.007	1.005	1.004	1.003
20	1.011	1.009	1.007	1.005	1.004	1.004	1.003	1.002	1.001
25	1.000	1.000	1.000	1.000	1.000	1.000	1.000	1.000	1.000
30	0.988	0.991	0.992	0.994	0.995	0.996	0.997	0.998	0.998
35	0.976	0.981	0.984	0.988	0.990	0.992	0.993	0.995	0.997
40	0.963	0.971	0.976	0.981	0.985	0.987	0.989	0.992	0.995
45	0.950	0.961	0.967	0.974	0.979	0.982	0.985	0.989	0.992
50	0.937	0.950	0.958	0.967	0.972	0.976	0.980	0.986	0.990
55	0.924	0.939	0.948	0.959	0.965	0.970	0.975	0.982	0.987
60	0.910	0.928	0.939	0.951	0.958	0.964	0.970	0.978	0.984
65	0.897	0.916	0.928	0.942	0.950	0.957	0.964	0.973	0.981
70	0.883	0.904	0.918	0.933	0.942	0.949	0.957	0.968	0.977
75	0.870	0.893	0.908	0.924	0.933	0.941	0.950	0.963	0.973
80	0.856	0.881	0.897	0.915	0.924	0.933	0.943	0.957	0.969
85	0.843	0.869	0.886	0.905	0.915	0.924	0.936	0.951	0.964
90	0.830	0.857	0.875	0.895	0.905	0.915	0.928	0.945	0.959
95	0.818	0.845	0.864	0.886	0.895	0.906	0.920	0.938	0.954
100	0.805	0.834	0.853	0.876	0.884	0.897	0.911	0.931	0.948

Temperature Characteristics - 2dB Product:

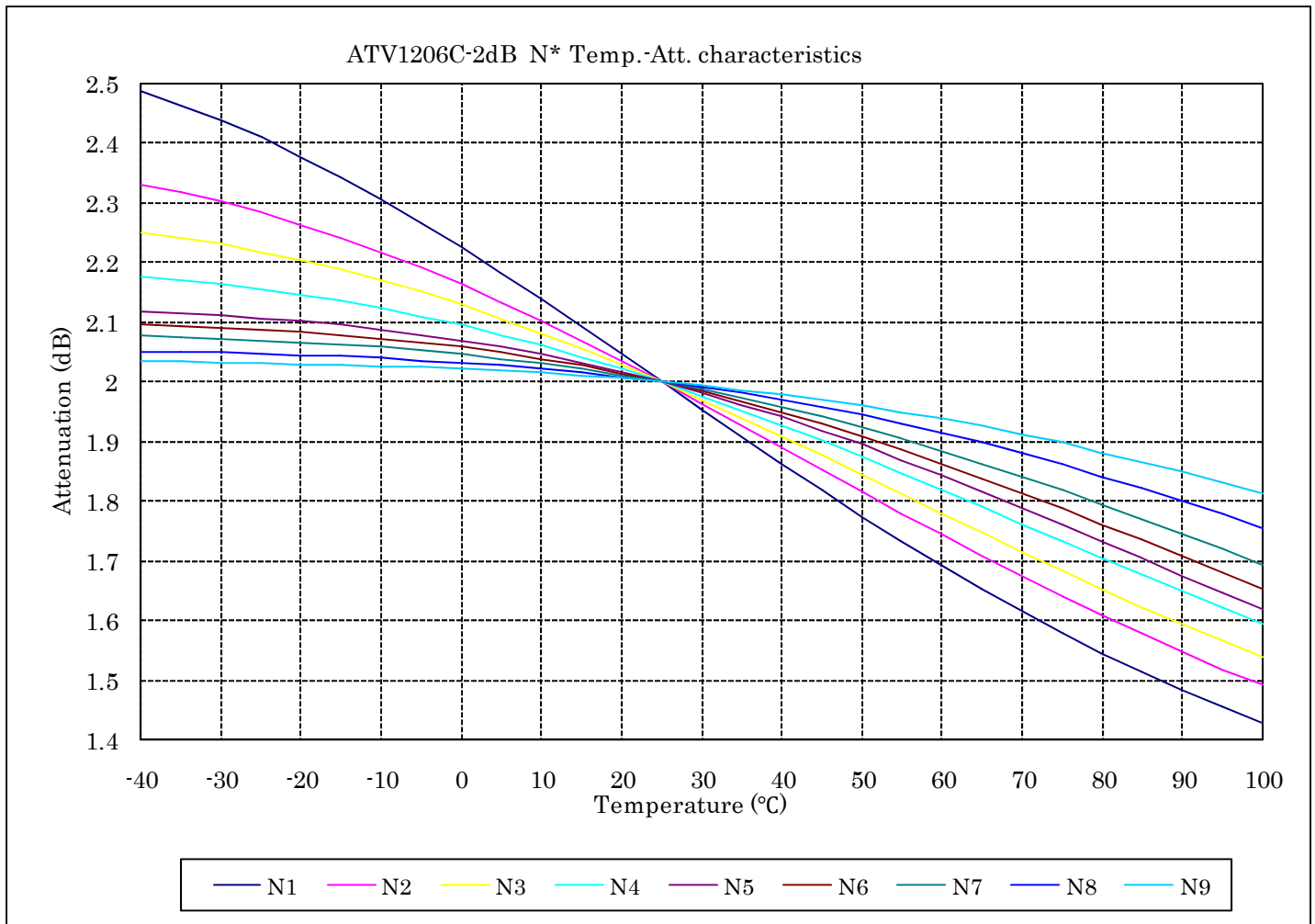

Attenuation at Temperatures Throughout Operating Temperature Range (2dB Product)

Temperature (°C)	N1	N2	N3	N4	N5	N6	N7	N8	N9
-40	2.488	2.331	2.251	2.176	2.118	2.097	2.077	2.051	2.034
-35	2.465	2.317	2.242	2.170	2.115	2.095	2.075	2.050	2.033
-30	2.439	2.302	2.231	2.163	2.111	2.092	2.073	2.049	2.032
-25	2.410	2.284	2.218	2.155	2.107	2.088	2.070	2.047	2.031
-20	2.378	2.264	2.204	2.146	2.101	2.084	2.067	2.045	2.030
-15	2.344	2.242	2.188	2.135	2.095	2.079	2.063	2.043	2.028
-10	2.307	2.218	2.170	2.123	2.088	2.073	2.058	2.040	2.026
-5	2.268	2.192	2.151	2.110	2.079	2.066	2.053	2.036	2.024
0	2.226	2.164	2.130	2.095	2.069	2.058	2.046	2.032	2.022
5	2.183	2.134	2.107	2.079	2.058	2.049	2.039	2.027	2.018
10	2.138	2.103	2.082	2.061	2.046	2.039	2.031	2.022	2.015
15	2.093	2.070	2.056	2.042	2.032	2.027	2.022	2.015	2.010
20	2.047	2.035	2.029	2.022	2.017	2.014	2.012	2.008	2.006
25	2.000	2.000	2.000	2.000	2.000	2.000	2.000	2.000	2.000
30	1.953	1.964	1.970	1.977	1.982	1.984	1.987	1.991	1.994
35	1.907	1.927	1.939	1.953	1.962	1.967	1.973	1.981	1.987
40	1.862	1.890	1.908	1.927	1.941	1.949	1.958	1.970	1.979
45	1.817	1.853	1.876	1.901	1.918	1.929	1.941	1.957	1.970
50	1.774	1.816	1.844	1.874	1.894	1.908	1.924	1.944	1.960
55	1.732	1.780	1.811	1.847	1.869	1.886	1.905	1.930	1.950
60	1.691	1.744	1.779	1.818	1.843	1.863	1.884	1.914	1.938
65	1.652	1.708	1.747	1.790	1.817	1.839	1.863	1.897	1.925
70	1.615	1.674	1.715	1.762	1.789	1.813	1.841	1.880	1.912
75	1.579	1.640	1.683	1.733	1.761	1.787	1.818	1.861	1.897
80	1.545	1.608	1.652	1.704	1.733	1.761	1.794	1.841	1.882
85	1.513	1.577	1.622	1.676	1.704	1.734	1.770	1.821	1.866
90	1.482	1.547	1.593	1.648	1.675	1.707	1.745	1.800	1.848
95	1.453	1.518	1.565	1.621	1.646	1.679	1.719	1.778	1.830
100	1.426	1.490	1.537	1.594	1.618	1.652	1.693	1.755	1.811

Temperature Characteristics - 3dB Product:

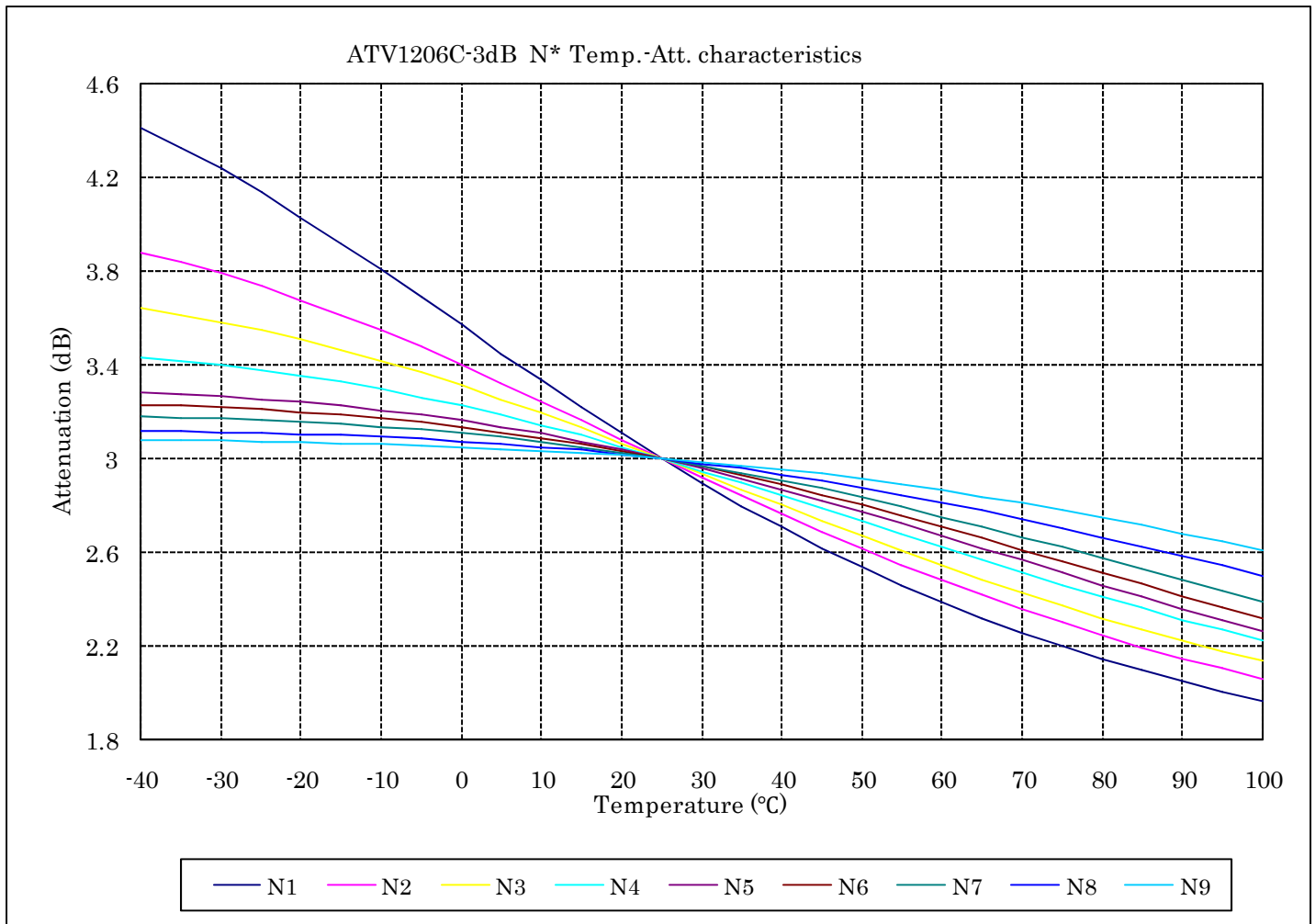

Attenuation at Temperatures Throughout Operating Temperature Range (3dB Product)

Temperature (°C)	N1	N2	N3	N4	N5	N6	N7	N8	N9
-40	4.415	3.880	3.641	3.433	3.283	3.230	3.180	3.119	3.078
-35	4.330	3.837	3.613	3.417	3.275	3.224	3.175	3.116	3.076
-30	4.237	3.789	3.582	3.399	3.265	3.216	3.170	3.113	3.074
-25	4.137	3.736	3.547	3.377	3.254	3.208	3.163	3.109	3.072
-20	4.031	3.677	3.507	3.353	3.240	3.197	3.155	3.104	3.069
-15	3.920	3.614	3.464	3.326	3.225	3.185	3.146	3.098	3.065
-10	3.805	3.547	3.417	3.295	3.206	3.170	3.135	3.091	3.061
-5	3.688	3.475	3.366	3.262	3.186	3.154	3.122	3.083	3.055
0	3.569	3.400	3.311	3.225	3.162	3.135	3.107	3.073	3.049
5	3.451	3.323	3.253	3.185	3.136	3.113	3.090	3.062	3.042
10	3.334	3.243	3.193	3.143	3.106	3.089	3.071	3.049	3.033
15	3.219	3.163	3.130	3.098	3.074	3.062	3.050	3.035	3.024
20	3.108	3.081	3.066	3.050	3.038	3.032	3.026	3.018	3.013
25	3.000	3.000	3.000	3.000	3.000	3.000	3.000	3.000	3.000
30	2.897	2.920	2.933	2.948	2.959	2.965	2.971	2.980	2.986
35	2.799	2.840	2.867	2.895	2.915	2.927	2.940	2.957	2.970
40	2.705	2.763	2.800	2.841	2.869	2.887	2.907	2.932	2.952
45	2.618	2.688	2.734	2.786	2.821	2.845	2.871	2.906	2.933
50	2.535	2.616	2.669	2.730	2.772	2.801	2.833	2.877	2.912
55	2.458	2.546	2.606	2.675	2.721	2.755	2.793	2.846	2.889
60	2.385	2.479	2.544	2.620	2.669	2.708	2.751	2.813	2.864
65	2.318	2.416	2.485	2.566	2.616	2.659	2.708	2.778	2.837
70	2.255	2.356	2.427	2.512	2.564	2.610	2.664	2.742	2.808
75	2.197	2.299	2.372	2.460	2.511	2.561	2.619	2.704	2.778
80	2.144	2.245	2.319	2.409	2.459	2.511	2.573	2.665	2.746
85	2.094	2.194	2.269	2.360	2.408	2.462	2.527	2.625	2.713
90	2.047	2.146	2.221	2.312	2.358	2.413	2.481	2.584	2.678
95	2.005	2.102	2.175	2.266	2.309	2.365	2.435	2.542	2.643
100	1.965	2.060	2.132	2.222	2.261	2.318	2.390	2.500	2.606

Temperature Characteristics - 4dB Product:

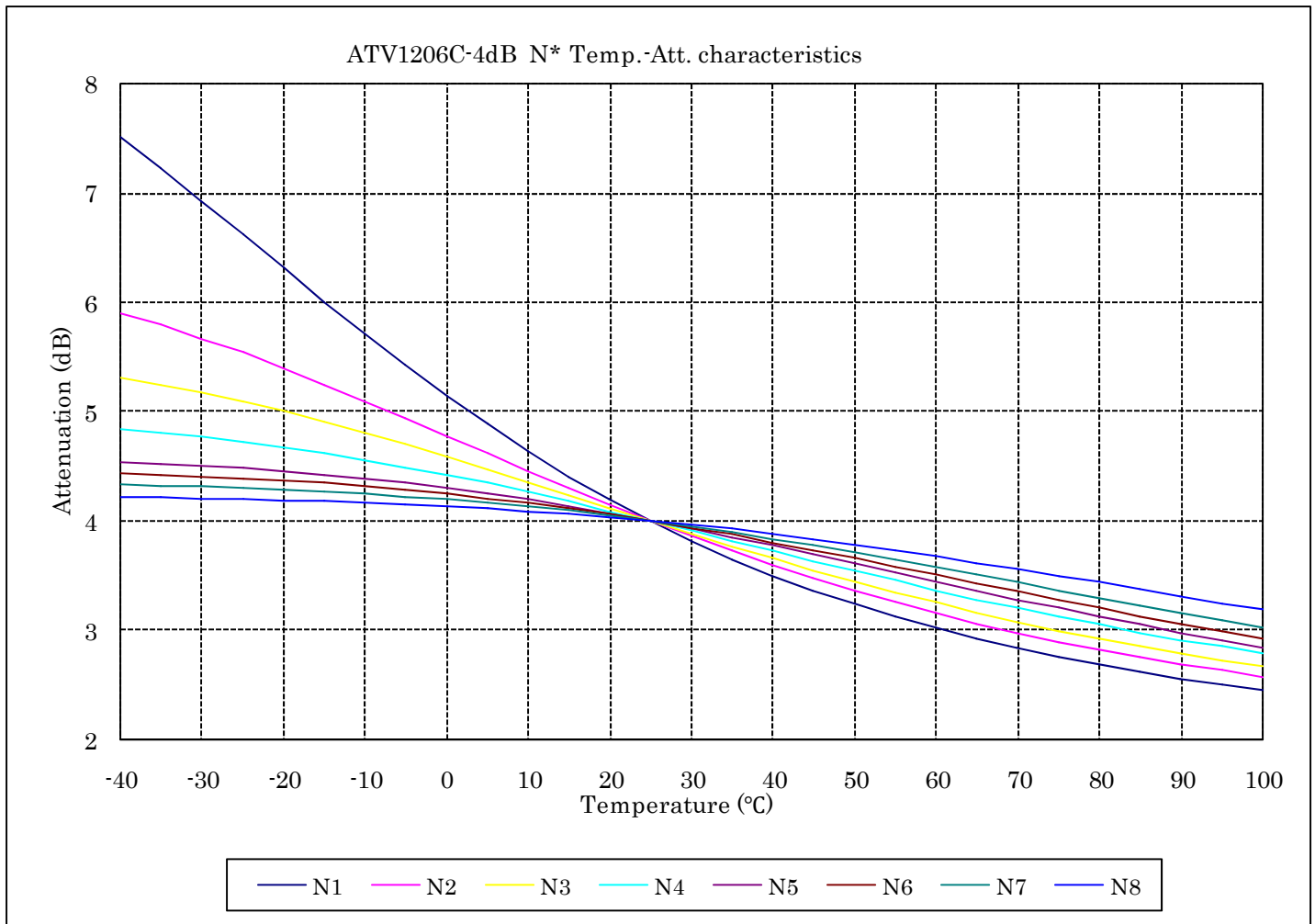

Attenuation at Temperatures Throughout Operating Temperature Range (4dB Product)

Temperature (°C)	N1	N2	N3	N4	N5	N6	N7	N8
-40	7.522	5.904	5.312	4.848	4.536	4.431	4.333	4.219
-35	7.231	5.793	5.248	4.813	4.520	4.419	4.325	4.213
-30	6.930	5.671	5.176	4.774	4.501	4.405	4.314	4.207
-25	6.623	5.539	5.096	4.729	4.478	4.387	4.302	4.200
-20	6.314	5.398	5.008	4.679	4.451	4.367	4.286	4.190
-15	6.009	5.250	4.913	4.623	4.421	4.343	4.269	4.179
-10	5.711	5.096	4.812	4.561	4.385	4.315	4.248	4.166
-5	5.422	4.938	4.705	4.494	4.345	4.284	4.224	4.151
0	5.146	4.778	4.593	4.422	4.300	4.248	4.196	4.133
5	4.885	4.617	4.477	4.345	4.250	4.207	4.165	4.113
10	4.639	4.457	4.359	4.263	4.194	4.162	4.130	4.089
15	4.410	4.301	4.239	4.178	4.134	4.112	4.090	4.063
20	4.197	4.148	4.119	4.090	4.069	4.058	4.047	4.033
25	4.000	4.000	4.000	4.000	4.000	4.000	4.000	4.000
30	3.819	3.858	3.882	3.908	3.927	3.938	3.949	3.964
35	3.653	3.723	3.767	3.816	3.851	3.872	3.894	3.924
40	3.501	3.594	3.655	3.723	3.772	3.802	3.836	3.880
45	3.362	3.473	3.547	3.631	3.691	3.730	3.774	3.834
50	3.235	3.359	3.443	3.541	3.608	3.656	3.710	3.784
55	3.120	3.252	3.344	3.452	3.525	3.581	3.643	3.732
60	3.015	3.152	3.249	3.366	3.442	3.504	3.575	3.676
65	2.919	3.059	3.160	3.282	3.360	3.427	3.505	3.619
70	2.832	2.972	3.075	3.201	3.279	3.350	3.435	3.559
75	2.753	2.892	2.996	3.123	3.199	3.274	3.364	3.498
80	2.681	2.818	2.921	3.049	3.122	3.199	3.293	3.436
85	2.616	2.749	2.850	2.978	3.047	3.126	3.223	3.373
90	2.556	2.685	2.785	2.911	2.975	3.055	3.154	3.310
95	2.501	2.626	2.723	2.847	2.906	2.986	3.087	3.246
100	2.452	2.572	2.666	2.787	2.840	2.920	3.021	3.183

Temperature Characteristics - 5dB Product:

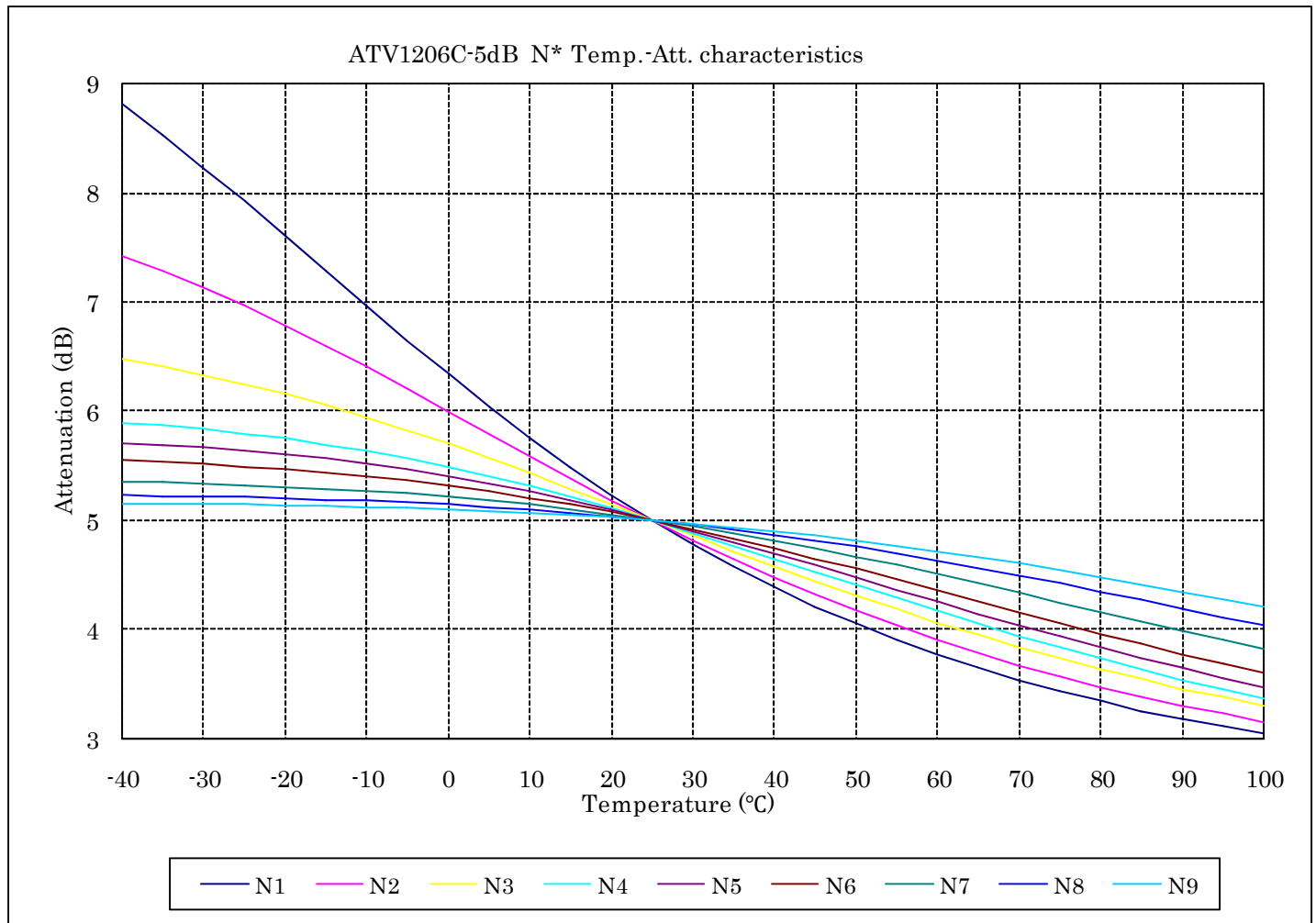

Attenuation at Temperatures Throughout Operating Temperature Range (5dB Product)

Temperature (°C)	N1	N2	N3	N4	N5	N6	N7	N8	N9
-40	8.810	7.416	6.472	5.897	5.713	5.545	5.353	5.228	5.157
-35	8.530	7.279	6.407	5.869	5.692	5.531	5.345	5.223	5.154
-30	8.232	7.127	6.333	5.835	5.667	5.513	5.334	5.217	5.150
-25	7.923	6.963	6.249	5.795	5.638	5.492	5.322	5.209	5.145
-20	7.605	6.786	6.156	5.749	5.603	5.466	5.307	5.200	5.139
-15	7.284	6.599	6.054	5.695	5.562	5.436	5.288	5.189	5.132
-10	6.963	6.404	5.942	5.634	5.515	5.402	5.267	5.176	5.123
-5	6.647	6.203	5.823	5.565	5.462	5.362	5.242	5.160	5.113
0	6.340	5.999	5.697	5.489	5.401	5.316	5.213	5.142	5.100
5	6.043	5.794	5.565	5.405	5.334	5.265	5.180	5.120	5.085
10	5.759	5.589	5.427	5.313	5.260	5.207	5.142	5.096	5.068
15	5.490	5.388	5.287	5.215	5.180	5.144	5.100	5.068	5.048
20	5.237	5.191	5.144	5.110	5.093	5.075	5.052	5.036	5.026
25	5.000	5.000	5.000	5.000	5.000	5.000	5.000	5.000	5.000
30	4.779	4.817	4.857	4.886	4.902	4.920	4.943	4.960	4.971
35	4.575	4.641	4.715	4.768	4.800	4.835	4.880	4.916	4.938
40	4.386	4.475	4.576	4.648	4.695	4.745	4.814	4.868	4.902
45	4.212	4.318	4.440	4.527	4.586	4.652	4.742	4.815	4.862
50	4.052	4.170	4.309	4.406	4.477	4.556	4.667	4.758	4.818
55	3.906	4.032	4.183	4.287	4.366	4.458	4.588	4.698	4.770
60	3.771	3.902	4.062	4.169	4.256	4.358	4.506	4.634	4.719
65	3.649	3.782	3.946	4.054	4.147	4.258	4.422	4.566	4.664
70	3.536	3.670	3.837	3.942	4.040	4.158	4.336	4.495	4.606
75	3.434	3.566	3.733	3.835	3.936	4.060	4.248	4.422	4.544
80	3.340	3.470	3.636	3.732	3.835	3.962	4.160	4.346	4.480
85	3.255	3.381	3.544	3.633	3.737	3.867	4.072	4.269	4.413
90	3.176	3.299	3.458	3.540	3.643	3.775	3.985	4.190	4.343
95	3.105	3.223	3.377	3.452	3.554	3.685	3.898	4.111	4.272
100	3.039	3.153	3.302	3.369	3.469	3.599	3.813	4.032	4.200

Temperature Characteristics - 6dB Product:

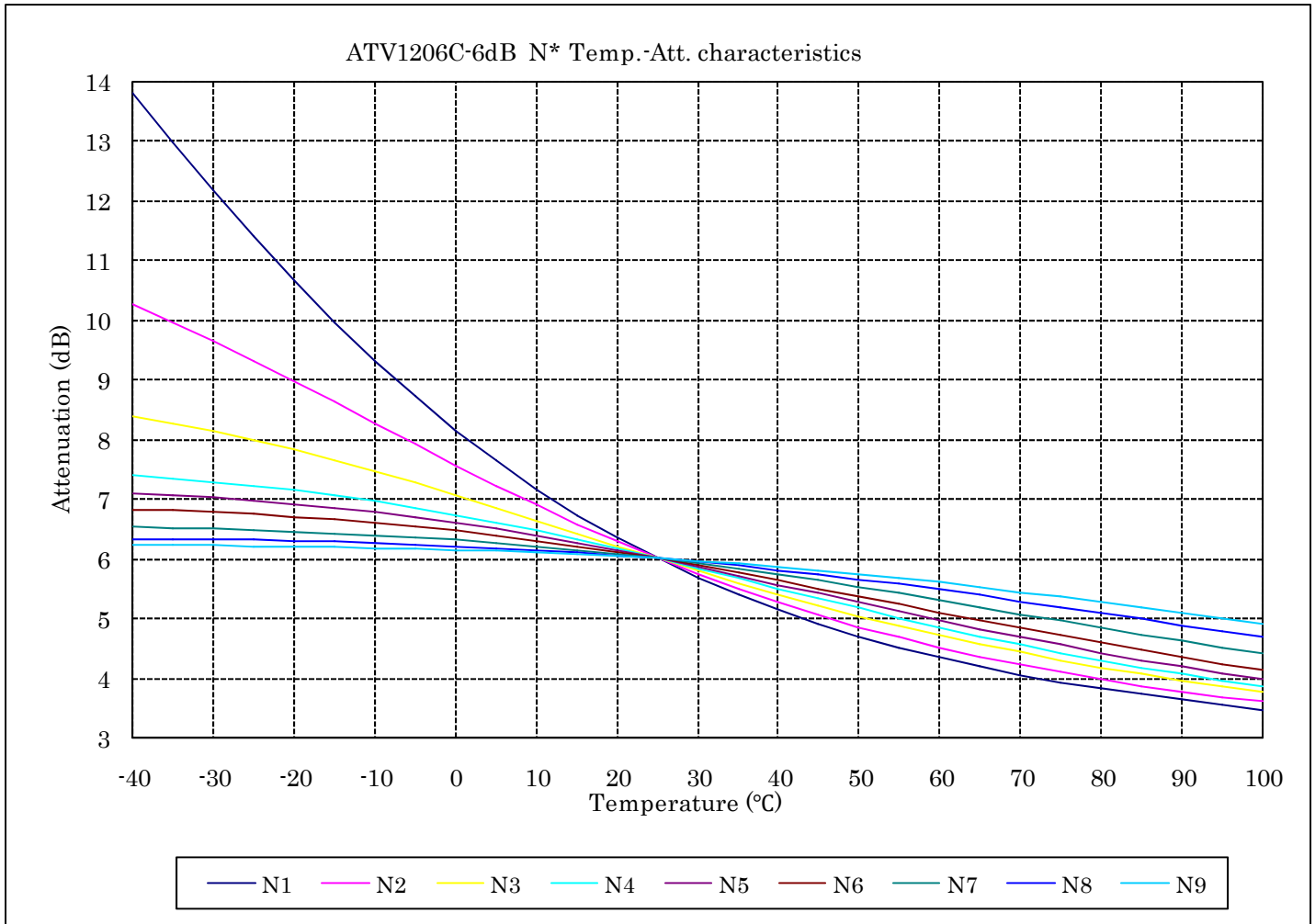

Attenuation at Temperatures Throughout Operating Temperature Range (6dB Product)

Temperature (°C)	N1	N2	N3	N4	N5	N6	N7	N8	N9
-40	13.813	10.262	8.392	7.393	7.093	6.826	6.527	6.337	6.231
-35	12.994	9.969	8.274	7.346	7.059	6.803	6.514	6.329	6.227
-30	12.192	9.654	8.141	7.291	7.020	6.775	6.499	6.320	6.221
-25	11.417	9.323	7.994	7.226	6.972	6.741	6.479	6.309	6.214
-20	10.678	8.978	7.831	7.150	6.916	6.702	6.456	6.295	6.205
-15	9.978	8.625	7.656	7.064	6.852	6.656	6.429	6.279	6.194
-10	9.323	8.269	7.469	6.966	6.778	6.602	6.396	6.259	6.181
-5	8.715	7.914	7.272	6.857	6.695	6.540	6.359	6.236	6.165
0	8.153	7.564	7.067	6.737	6.601	6.471	6.315	6.208	6.147
5	7.638	7.224	6.856	6.607	6.498	6.393	6.265	6.177	6.125
10	7.167	6.895	6.642	6.466	6.386	6.307	6.209	6.140	6.100
15	6.739	6.580	6.426	6.317	6.265	6.212	6.146	6.099	6.071
20	6.351	6.282	6.212	6.161	6.136	6.110	6.077	6.052	6.038
25	6.000	6.000	6.000	6.000	6.000	6.000	6.000	6.000	6.000
30	5.683	5.736	5.793	5.835	5.858	5.884	5.917	5.942	5.958
35	5.397	5.490	5.592	5.667	5.713	5.762	5.827	5.878	5.910
40	5.140	5.261	5.399	5.499	5.564	5.635	5.732	5.809	5.858
45	4.909	5.049	5.214	5.332	5.413	5.504	5.631	5.734	5.801
50	4.700	4.854	5.037	5.168	5.263	5.372	5.525	5.654	5.738
55	4.513	4.674	4.870	5.008	5.114	5.237	5.416	5.568	5.671
60	4.344	4.509	4.713	4.852	4.967	5.103	5.303	5.479	5.598
65	4.192	4.357	4.565	4.703	4.824	4.970	5.189	5.385	5.521
70	4.055	4.219	4.426	4.560	4.685	4.839	5.073	5.288	5.440
75	3.931	4.091	4.297	4.424	4.552	4.710	4.957	5.188	5.355
80	3.820	3.975	4.176	4.295	4.424	4.585	4.841	5.087	5.267
85	3.719	3.868	4.064	4.174	4.302	4.464	4.726	4.984	5.176
90	3.627	3.771	3.960	4.060	4.186	4.348	4.614	4.880	5.083
95	3.544	3.682	3.863	3.953	4.076	4.237	4.504	4.777	4.989
100	3.469	3.600	3.774	3.854	3.973	4.131	4.397	4.674	4.893

Temperature Characteristics - 7dB Product:

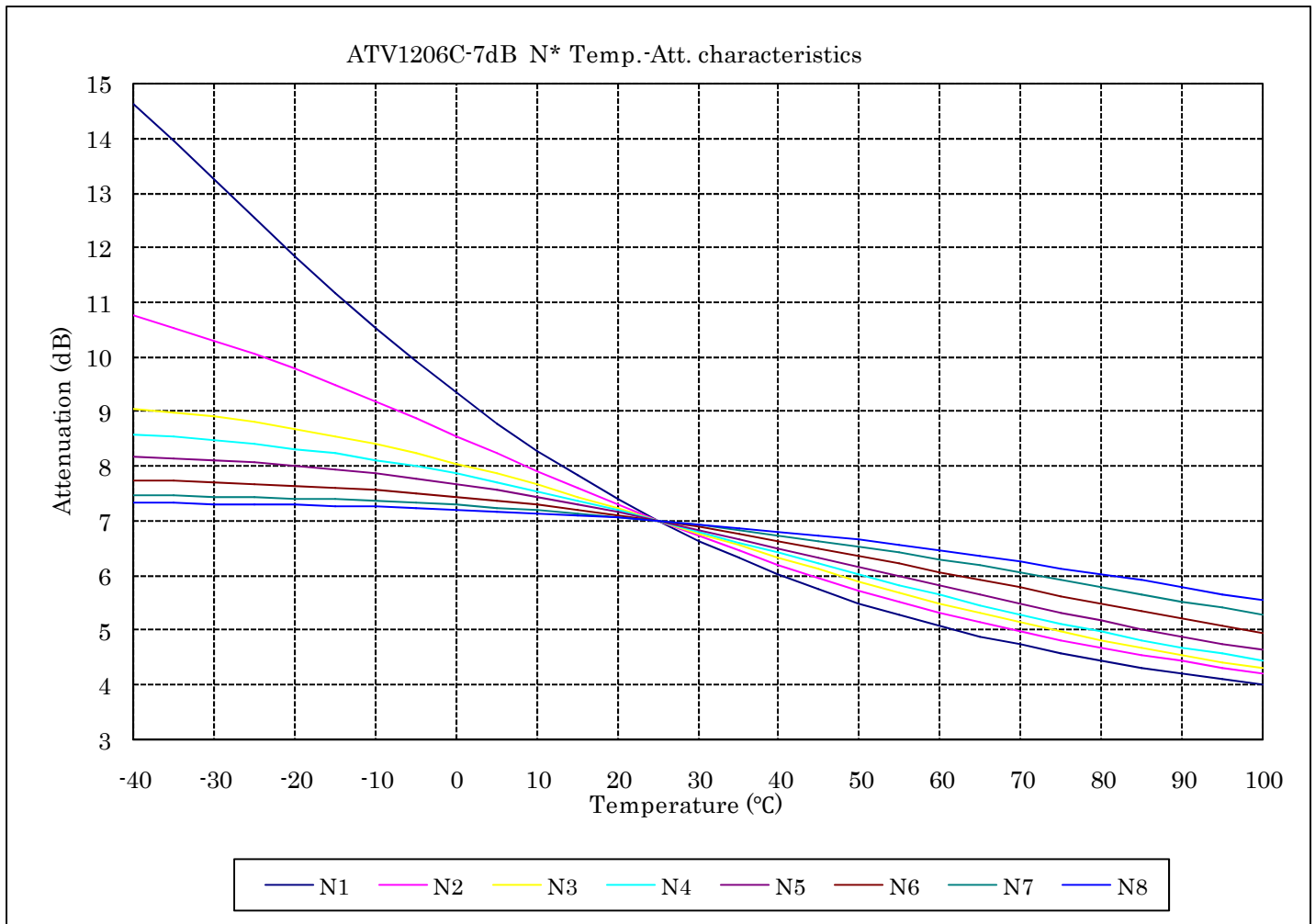

Attenuation at Temperatures Throughout Operating Temperature Range (7dB Product)

Temperature (°C)	N1	N2	N3	N4	N5	N6	N7	N8
-40	14.643	10.754	9.063	8.593	8.187	7.747	7.473	7.323
-35	13.949	10.543	8.989	8.542	8.153	7.728	7.462	7.316
-30	13.246	10.310	8.902	8.480	8.111	7.705	7.449	7.308
-25	12.544	10.055	8.800	8.408	8.061	7.677	7.433	7.298
-20	11.852	9.780	8.682	8.324	8.003	7.644	7.413	7.285
-15	11.180	9.489	8.549	8.226	7.934	7.604	7.390	7.270
-10	10.534	9.185	8.399	8.116	7.856	7.558	7.362	7.252
-5	9.919	8.872	8.234	7.992	7.766	7.504	7.329	7.230
0	9.339	8.553	8.055	7.855	7.665	7.442	7.291	7.204
5	8.796	8.233	7.862	7.705	7.553	7.371	7.246	7.174
10	8.291	7.914	7.658	7.543	7.430	7.292	7.195	7.139
15	7.824	7.601	7.445	7.370	7.296	7.203	7.137	7.098
20	7.394	7.295	7.225	7.189	7.152	7.106	7.072	7.052
25	7.000	7.000	7.000	7.000	7.000	7.000	7.000	7.000
30	6.640	6.717	6.773	6.806	6.840	6.886	6.920	6.942
35	6.312	6.448	6.547	6.608	6.674	6.763	6.833	6.877
40	6.014	6.193	6.324	6.410	6.504	6.634	6.738	6.805
45	5.743	5.953	6.106	6.212	6.331	6.499	6.637	6.727
50	5.497	5.728	5.894	6.016	6.157	6.359	6.529	6.643
55	5.275	5.518	5.690	5.825	5.983	6.215	6.416	6.552
60	5.073	5.322	5.495	5.639	5.811	6.069	6.297	6.456
65	4.891	5.141	5.310	5.460	5.643	5.921	6.175	6.354
70	4.726	4.974	5.135	5.289	5.478	5.773	6.049	6.247
75	4.576	4.819	4.970	5.125	5.319	5.626	5.920	6.136
80	4.440	4.676	4.816	4.970	5.166	5.481	5.790	6.022
85	4.317	4.544	4.673	4.824	5.019	5.339	5.660	5.905
90	4.205	4.423	4.539	4.687	4.880	5.201	5.530	5.786
95	4.104	4.311	4.415	4.558	4.748	5.067	5.402	5.666
100	4.011	4.209	4.300	4.438	4.623	4.938	5.275	5.546

Temperature Characteristics - 8dB Product:

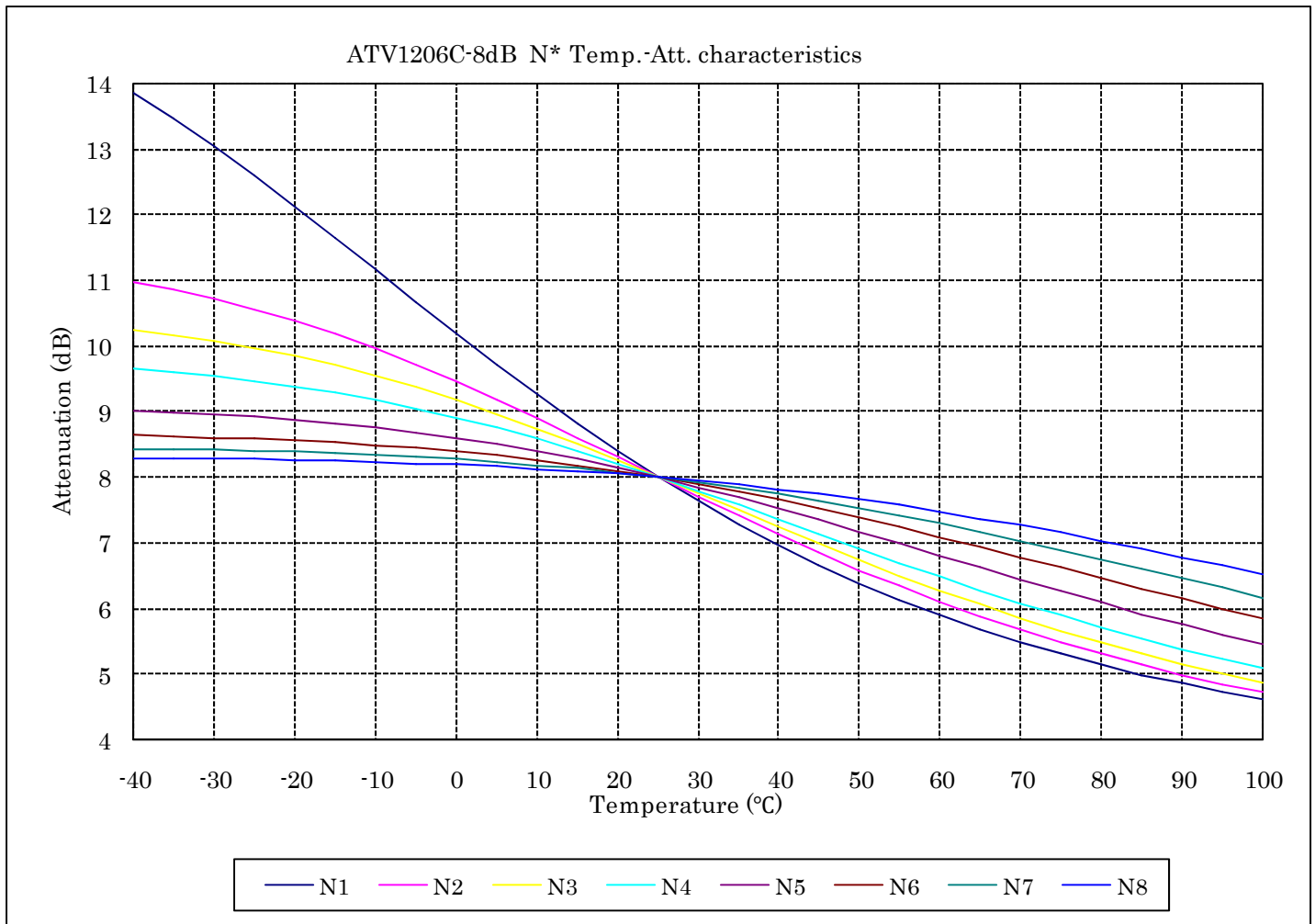

Attenuation at Temperatures Throughout Operating Temperature Range (8dB Product)

Temperature (°C)	N1	N2	N3	N4	N5	N6	N7	N8
-40	13.853	10.967	10.246	9.647	9.019	8.638	8.433	8.292
-35	13.464	10.852	10.170	9.597	8.993	8.624	8.425	8.287
-30	13.043	10.717	10.078	9.537	8.960	8.606	8.413	8.279
-25	12.596	10.560	9.971	9.466	8.922	8.584	8.400	8.271
-20	12.129	10.381	9.846	9.381	8.875	8.557	8.383	8.260
-15	11.648	10.180	9.704	9.284	8.820	8.525	8.362	8.246
-10	11.160	9.958	9.544	9.172	8.756	8.487	8.337	8.230
-5	10.670	9.716	9.366	9.046	8.681	8.442	8.308	8.210
0	10.187	9.456	9.171	8.905	8.596	8.390	8.273	8.187
5	9.713	9.182	8.960	8.749	8.499	8.330	8.232	8.160
10	9.255	8.895	8.735	8.579	8.391	8.261	8.185	8.128
15	8.815	8.600	8.498	8.397	8.272	8.183	8.131	8.091
20	8.396	8.301	8.252	8.203	8.141	8.096	8.069	8.048
25	8.000	8.000	8.000	8.000	8.000	8.000	8.000	8.000
30	7.628	7.702	7.744	7.789	7.849	7.894	7.923	7.945
35	7.280	7.408	7.487	7.573	7.688	7.779	7.837	7.884
40	6.957	7.123	7.232	7.353	7.520	7.656	7.743	7.816
45	6.658	6.848	6.981	7.132	7.346	7.524	7.641	7.741
50	6.381	6.585	6.737	6.912	7.167	7.385	7.532	7.659
55	6.127	6.335	6.501	6.696	6.985	7.240	7.414	7.570
60	5.893	6.100	6.274	6.484	6.802	7.089	7.291	7.474
65	5.678	5.878	6.058	6.278	6.618	6.935	7.161	7.372
70	5.482	5.671	5.853	6.079	6.436	6.777	7.026	7.263
75	5.302	5.478	5.659	5.889	6.257	6.618	6.886	7.149
80	5.137	5.299	5.478	5.707	6.082	6.458	6.743	7.030
85	4.987	5.134	5.308	5.535	5.912	6.299	6.599	6.907
90	4.850	4.981	5.150	5.373	5.748	6.142	6.452	6.781
95	4.724	4.841	5.003	5.220	5.591	5.987	6.306	6.651
100	4.609	4.711	4.867	5.077	5.440	5.836	6.160	6.520

Temperature Characteristics - 9dB Product:

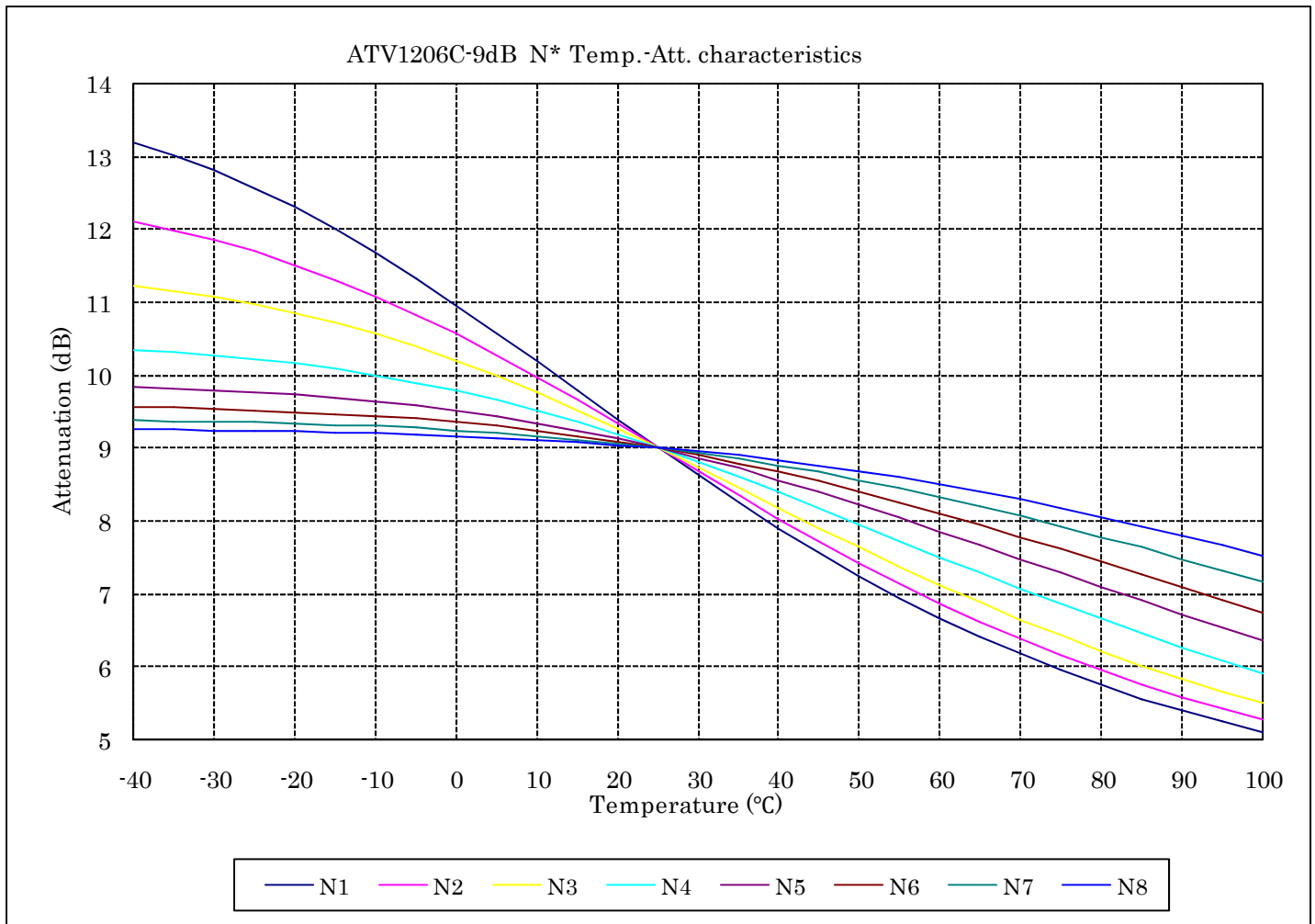

Attenuation at Temperatures Throughout Operating Temperature Range (9dB Product)

Temperature (°C)	N1	N2	N3	N4	N5	N6	N7	N8
-40	13.204	12.102	11.230	10.353	9.838	9.566	9.380	9.254
-35	13.023	11.988	11.159	10.317	9.818	9.554	9.372	9.249
-30	12.813	11.853	11.074	10.273	9.795	9.539	9.363	9.244
-25	12.573	11.696	10.973	10.220	9.765	9.521	9.351	9.236
-20	12.303	11.516	10.855	10.157	9.730	9.499	9.337	9.227
-15	12.003	11.311	10.718	10.082	9.687	9.472	9.320	9.216
-10	11.677	11.083	10.563	9.995	9.637	9.439	9.298	9.202
-5	11.328	10.833	10.389	9.895	9.577	9.400	9.273	9.186
0	10.960	10.562	10.197	9.781	9.508	9.355	9.243	9.166
5	10.577	10.272	9.986	9.653	9.429	9.301	9.207	9.142
10	10.184	9.968	9.759	9.510	9.339	9.240	9.165	9.114
15	9.787	9.652	9.518	9.353	9.238	9.169	9.117	9.081
20	9.391	9.328	9.264	9.183	9.125	9.090	9.062	9.044
25	9.000	9.000	9.000	9.000	9.000	9.000	9.000	9.000
30	8.618	8.672	8.730	8.806	8.864	8.900	8.930	8.950
35	8.249	8.348	8.455	8.602	8.717	8.791	8.851	8.894
40	7.896	8.030	8.180	8.390	8.561	8.671	8.764	8.831
45	7.560	7.722	7.907	8.172	8.395	8.542	8.668	8.760
50	7.243	7.425	7.638	7.950	8.221	8.404	8.564	8.682
55	6.945	7.141	7.375	7.727	8.040	8.257	8.452	8.597
60	6.667	6.872	7.121	7.503	7.854	8.103	8.331	8.504
65	6.409	6.618	6.876	7.282	7.665	7.942	8.204	8.403
70	6.170	6.379	6.643	7.065	7.473	7.776	8.069	8.295
75	5.949	6.156	6.421	6.852	7.281	7.606	7.928	8.181
80	5.746	5.949	6.212	6.647	7.090	7.433	7.782	8.059
85	5.560	5.757	6.014	6.449	6.902	7.258	7.631	7.932
90	5.389	5.578	5.830	6.259	6.716	7.084	7.478	7.800
95	5.233	5.414	5.657	6.078	6.536	6.910	7.322	7.663
100	5.090	5.263	5.496	5.906	6.360	6.738	7.165	7.522

Temperature Characteristics - 10dB Product:

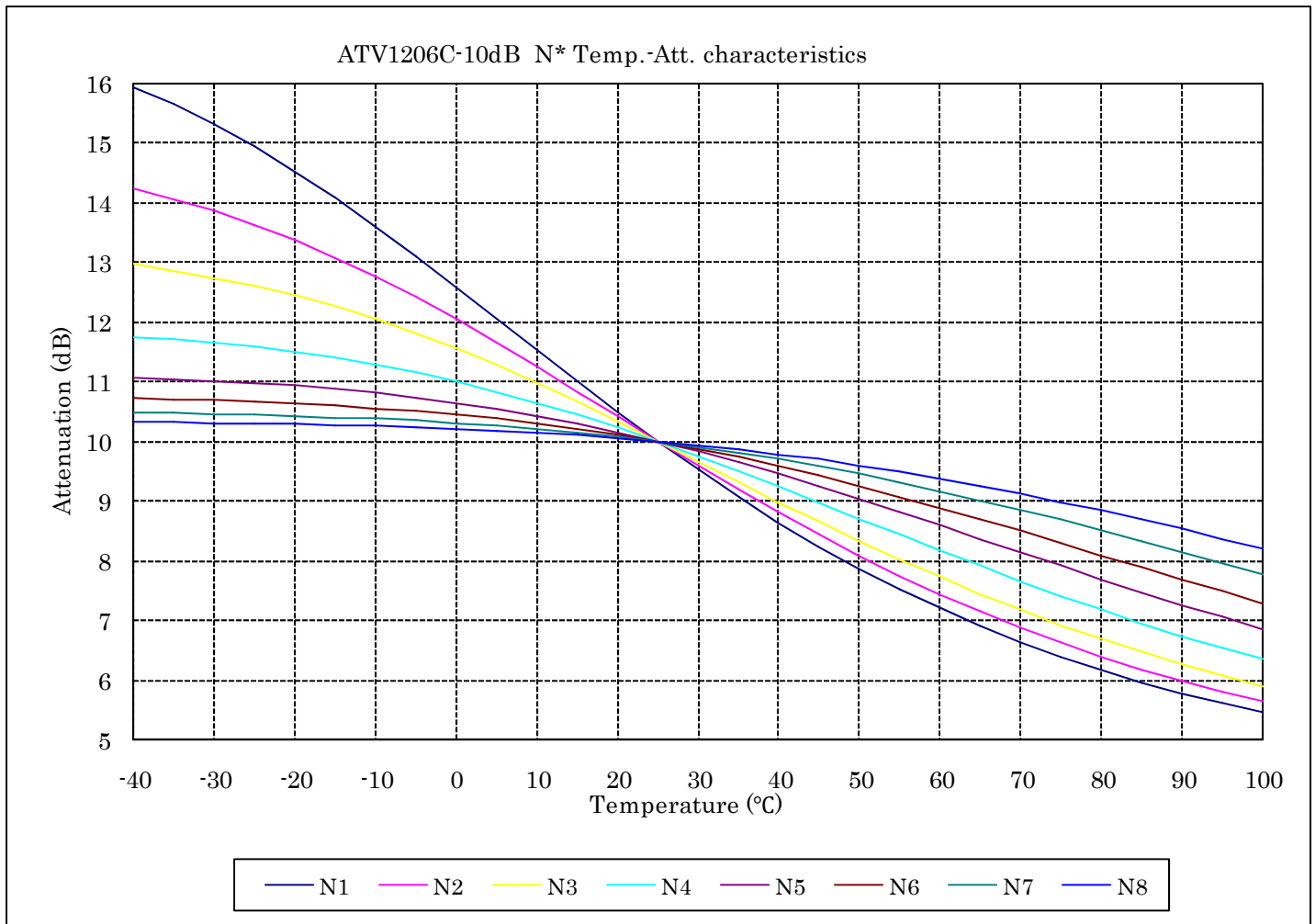

Attenuation at Temperatures Throughout Operating Temperature Range (10dB Product)

Temperature (°C)	N1	N2	N3	N4	N5	N6	N7	N8
-40	15.952	14.238	12.971	11.761	11.077	10.722	10.483	10.322
-35	15.661	14.068	12.870	11.712	11.051	10.707	10.473	10.316
-30	15.328	13.869	12.751	11.654	11.020	10.688	10.461	10.309
-25	14.954	13.640	12.610	11.583	10.982	10.665	10.447	10.299
-20	14.540	13.378	12.446	11.498	10.935	10.636	10.428	10.288
-15	14.091	13.086	12.258	11.399	10.880	10.601	10.406	10.274
-10	13.612	12.764	12.046	11.284	10.814	10.559	10.378	10.256
-5	13.110	12.416	11.810	11.152	10.737	10.509	10.346	10.235
0	12.591	12.044	11.552	11.003	10.648	10.450	10.307	10.210
5	12.064	11.653	11.272	10.835	10.546	10.382	10.262	10.180
10	11.535	11.248	10.974	10.651	10.430	10.304	10.209	10.144
15	11.010	10.834	10.660	10.449	10.301	10.214	10.148	10.103
20	10.497	10.416	10.334	10.232	10.157	10.113	10.079	10.055
25	10.000	10.000	10.000	10.000	10.000	10.000	10.000	10.000
30	9.523	9.590	9.661	9.756	9.829	9.875	9.911	9.937
35	9.070	9.190	9.322	9.502	9.646	9.738	9.813	9.867
40	8.641	8.803	8.985	9.241	9.452	9.589	9.704	9.788
45	8.240	8.433	8.654	8.975	9.247	9.429	9.585	9.700
50	7.866	8.080	8.333	8.707	9.034	9.258	9.456	9.603
55	7.519	7.747	8.022	8.439	8.815	9.079	9.317	9.497
60	7.198	7.434	7.724	8.173	8.591	8.891	9.170	9.381
65	6.904	7.142	7.440	7.912	8.365	8.697	9.014	9.258
70	6.633	6.870	7.171	7.658	8.137	8.497	8.850	9.126
75	6.386	6.618	6.918	7.412	7.911	8.294	8.680	8.986
80	6.160	6.385	6.680	7.175	7.688	8.090	8.505	8.839
85	5.953	6.171	6.459	6.949	7.469	7.884	8.325	8.685
90	5.766	5.974	6.252	6.734	7.255	7.680	8.143	8.526
95	5.595	5.793	6.061	6.530	7.048	7.479	7.959	8.363
100	5.439	5.627	5.883	6.337	6.849	7.281	7.775	8.196

Temperature Characteristics - 16dB Product:

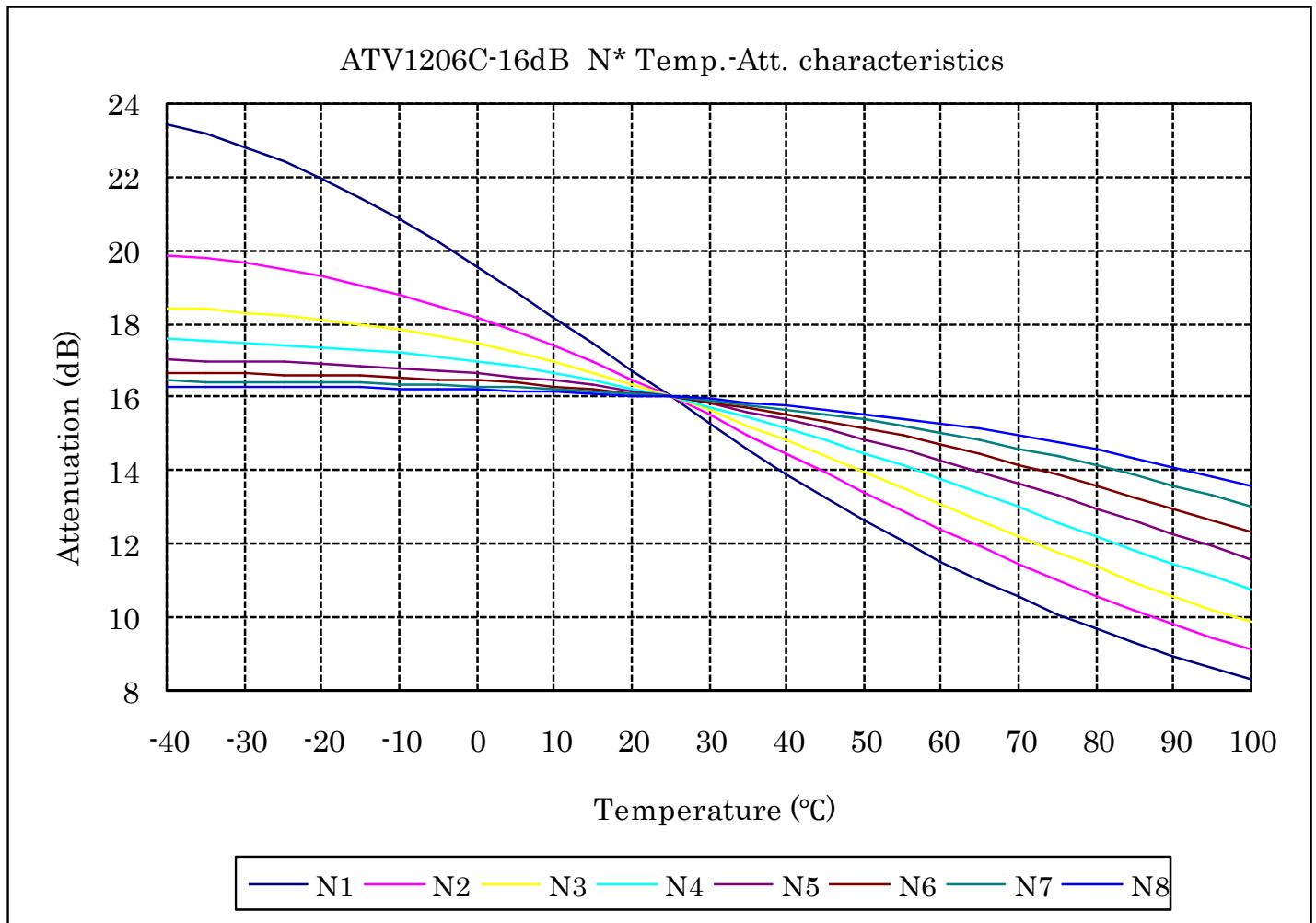

Attenuation at Temperatures Throughout Operating Temperature Range (16dB Product)

Temperature (°C)	N1	N2	N3	N4	N5	N6	N7	N8
-40	23.474	19.894	18.445	17.570	17.020	16.662	16.443	16.293
-35	23.174	19.783	18.387	17.536	17.001	16.651	16.437	16.289
-30	22.821	19.648	18.315	17.495	16.976	16.636	16.428	16.283
-25	22.411	19.485	18.227	17.443	16.945	16.618	16.416	16.277
-20	21.944	19.291	18.120	17.379	16.907	16.596	16.402	16.268
-15	21.423	19.064	17.991	17.302	16.860	16.567	16.384	16.256
-10	20.850	18.801	17.839	17.210	16.803	16.532	16.361	16.242
-5	20.231	18.501	17.662	17.100	16.735	16.489	16.333	16.224
0	19.574	18.165	17.457	16.972	16.653	16.438	16.299	16.202
5	18.885	17.793	17.223	16.823	16.557	16.376	16.258	16.175
10	18.175	17.387	16.960	16.652	16.445	16.302	16.209	16.142
15	17.451	16.951	16.668	16.458	16.315	16.216	16.150	16.103
20	16.724	16.487	16.347	16.241	16.167	16.116	16.081	16.056
25	16.000	16.000	16.000	16.000	16.000	16.000	16.000	16.000
30	15.287	15.496	15.628	15.736	15.813	15.868	15.907	15.935
35	14.592	14.980	15.235	15.449	15.605	15.719	15.800	15.859
40	13.920	14.458	14.824	15.141	15.376	15.551	15.678	15.771
45	13.274	13.934	14.398	14.814	15.128	15.365	15.541	15.671
50	12.659	13.415	13.963	14.470	14.861	15.161	15.387	15.557
55	12.076	12.903	13.521	14.112	14.576	14.938	15.218	15.428
60	11.526	12.404	13.078	13.743	14.276	14.697	15.031	15.285
65	11.011	11.920	12.637	13.365	13.961	14.440	14.828	15.127
70	10.529	11.454	12.201	12.983	13.635	14.167	14.608	14.952
75	10.082	11.009	11.774	12.599	13.299	13.880	14.373	14.762
80	9.667	10.585	11.359	12.217	12.957	13.581	14.124	14.557
85	9.283	10.184	10.957	11.838	12.611	13.272	13.861	14.336
90	8.929	9.805	10.570	11.465	12.263	12.954	13.586	14.102
95	8.603	9.450	10.201	11.101	11.916	12.632	13.301	13.854
100	8.304	9.117	9.849	10.748	11.572	12.305	13.008	13.595