



Product Family: [Temperature Variable Attenuators](#)

Part Number Series: [ATV0805C Series](#)

	<p>Construction:</p> <ul style="list-style-type: none"> • High purity Alumina Substrate • Thermo-sensitive thermistor • Ni alloy thin-film resistive elements • 100% matte tin finish terminations (RoHS compliant and Pb Free) 	<p>Features:</p> <ul style="list-style-type: none"> • 0805 English case size • 63mW power rating • Attenuation values between 1 and 10dB • ± 0.5dB attenuation tolerance • DC to 3GHz • High volume production suitable for commercial and special applications
--	--	---

The ATV0805C series of temperature variable attenuators utilizes a temperature-sensitive thermistor to control attenuation change over temperature. These are useful in replacing temperature compensation circuits and can simplify auto gain control (AGC) and circuit design in power amplification devices resulting in reduced design time, reduced board space and cost savings due to the reduced number of components required for these control circuits.

Product Dimensions:

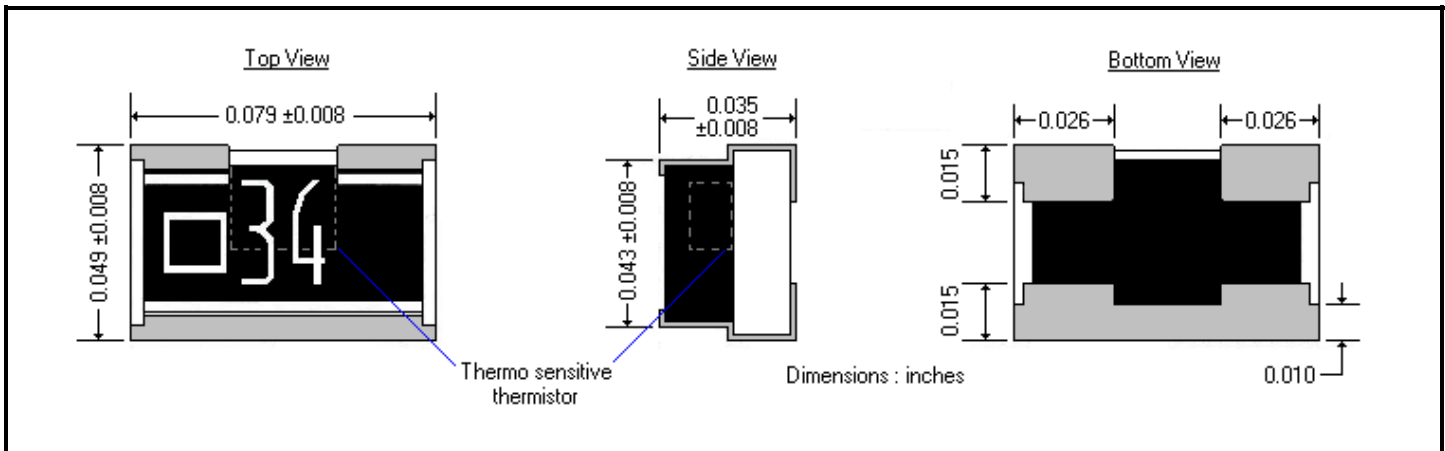

Schematic and Derating Curve:

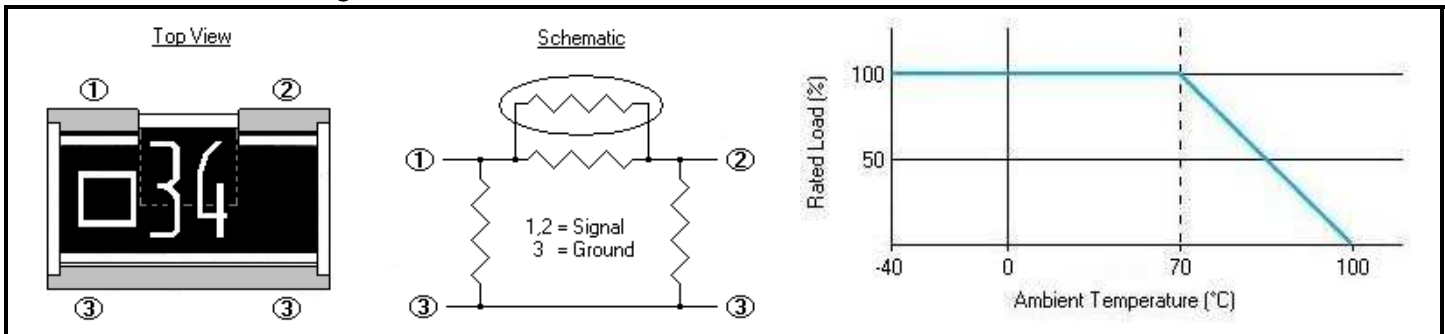

ATV Series Part Numbering: Ex: ATV0805C-03DBN7

Product Designator	English Size	Frequency	Attenuation Value	Temperature Characteristic
ATV	0805	C = 3 GHz	- 01DB = 1dB, - 02DB = 2dB, - 03DB = 3dB, - 04DB = 4dB, - 05DB = 5dB, - 06DB = 6dB, - 07DB = 7dB, - 08DB = 8dB, - 09DB = 9dB, - 10DB = 10dB	Refer to electrical tables N1, N2, N3, N4, N5, N6, N7, N8, N9

Electrical Specifications:

Type	ATV0805C
English Size	0805
Metric Size	2012
Attenuation (at 25°C)	1, 2, 3, 4, 5, 6, 7, 8, 9, 10dB
Attenuation Tolerance (at 25°C)	±0.5dB
Impedance	50Ω
VSWR	Less than 1.3 (Refer to VSWR temperature table)
Temperature Characteristic	Each attenuation has either 8 or 9 available temperature characteristics, N1 ~ N9. (Refer to temperature characteristic graphs)
Frequency Range	DC to 3 GHz
Power Rating	63mW (refer to derating curve)
Operating Temperature Range	-40°C to 100°C
Rated Ambient Temperature	70°C
Packaging	Tape & Reel (1,000 pcs/reel)

Reliability Specifications:

Test	Test Method	Specification	
		Attenuation	Impedance
Short Time Overload	Applied voltage: 2.5X rated voltage or 2X maximum operating voltage, whichever is less. Test duration: 5 seconds	±0.1dB	±1%
Load Life	Test Temperature: 70°C Applied voltage: rated voltage Test period: 1000 hours with power cycling as follows: 90 min. power ON/30 min. power OFF,	±0.2dB	±2%
Moisture Load Life	Test Condition: 60°C/90-95% RH Applied voltage: rated voltage Test period: 1000 hours with power cycling as follows: 90 min. power ON/30 min. power OFF	±0.2dB	±2%
Temperature Cycle	Repeat 5 cycles as follows: -40°C(30 min.) / Room temp (3 min) / +100°C(30 min.) / Room temp (3 min)	±0.1dB	±1%
Resistance to Soldering Heat	Solder dip at 260°C for 10 seconds	±0.1dB	±1%
Vibration	Sine Wave: 10~55Hz, Amplitude 1.5mm, Sweeping condition: 10~55Hz-10Hz/minute added amplitude time: XYZ each 2 hours	±0.1dB	±1%
Solderability	Solder dip at 245°C for 3 seconds	A new uniform coating of solder shall cover a minimum of 95% of immersed surface.	

Tape and Reel Dimensions:

	Symbol	Dimensions (mm)	Symbol	Dimensions (mm)
	A	1.45 ±0.1	P ₀	4.0 ±0.1
B	2.3 ±0.1	P ₁	4.0 ±0.1	
W	8.0 ±0.1	P ₂	2.0 ±0.05	
F	3.5 ±0.05	D ₀	1.5 +0.1/-0	
E	1.75 ±0.1	D ₁	1.0 +0.2/-0	
T	1.3 ±0.2	t	0.25 ±0.05	

Recommended Land Pattern:

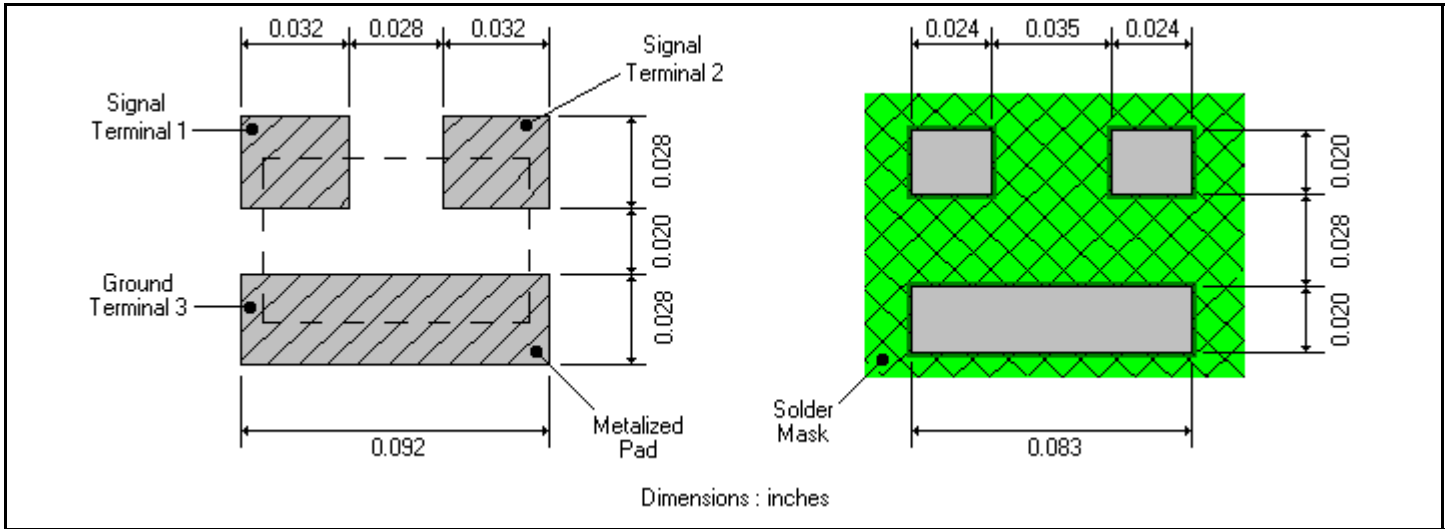

Compensation Example:

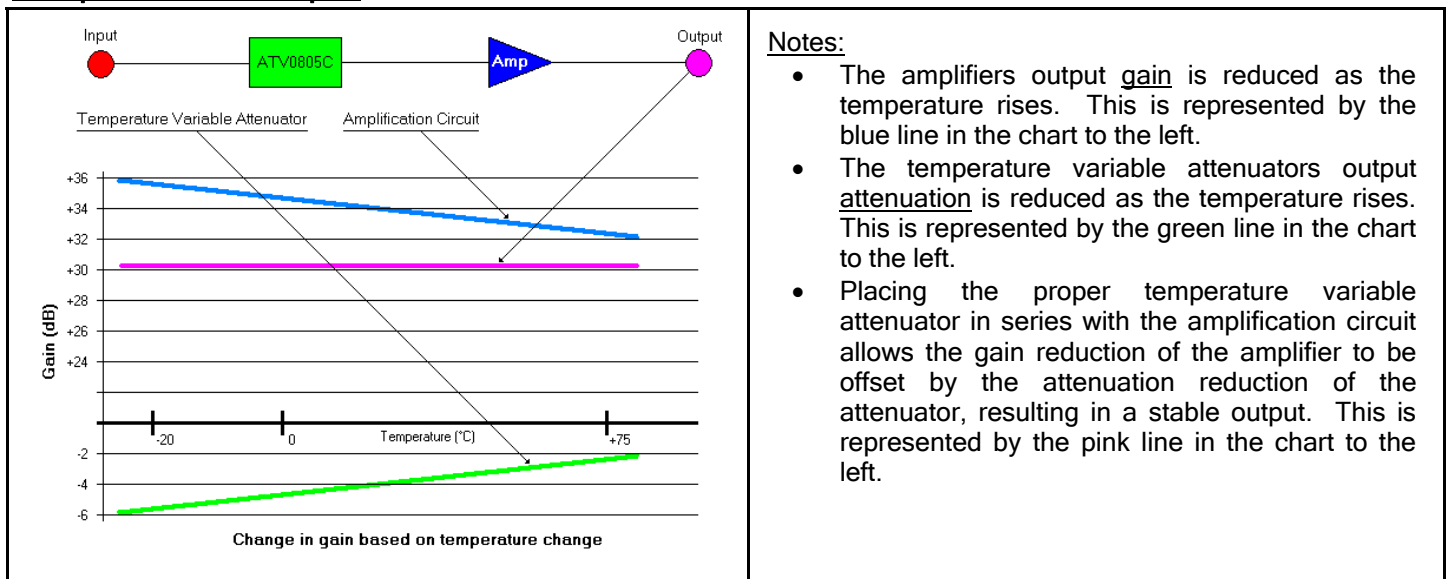

Notes:

- The amplifiers output gain is reduced as the temperature rises. This is represented by the blue line in the chart to the left.
- The temperature variable attenuators output attenuation is reduced as the temperature rises. This is represented by the green line in the chart to the left.
- Placing the proper temperature variable attenuator in series with the amplification circuit allows the gain reduction of the amplifier to be offset by the attenuation reduction of the attenuator, resulting in a stable output. This is represented by the pink line in the chart to the left.

VSWR Temperature Table:

The table below shows VSWR values which are at or above 1.3 due to temperature influence.

Temp.	4dB		5dB		6dB		7dB		8dB		9dB		10dB	
	N1	N2	N1	N2	N1	N2	N1	N2	N1	N2	N1	N2	N1	N2
-40°C	1.6	1.6	1.3	2.0	1.5	1.8	1.4	1.5		1.3		1.4		
-35°C	1.6	1.5	1.3	1.9	1.5	1.7	1.4	1.5		1.3		1.3		
-30°C	1.5	1.5	1.3	1.8	1.5	1.7	1.4	1.5		1.3		1.3		
-25°C	1.5	1.4	1.3	1.7	1.4	1.6	1.3	1.4				1.3		
-20°C	1.4	1.4		1.6	1.4	1.6	1.3	1.4				1.3		
-15°C	1.4	1.4		1.6	1.3	1.5		1.3						
-10°C	1.3	1.3		1.5	1.3	1.4		1.3						
-5°C				1.4		1.3								
0°C				1.3										
80°C						1.3		1.3				1.3		
85°C				1.3		1.3		1.3		1.3		1.3	1.3	1.3
90°C				1.3		1.3	1.3	1.3		1.3	1.3	1.3	1.3	1.3
95°C				1.3	1.3	1.3	1.3	1.3	1.3	1.3	1.3	1.3	1.3	1.3
100°C				1.3	1.3	1.3	1.3	1.3	1.3	1.3	1.3	1.3	1.3	1.3

Reel Dimensions:

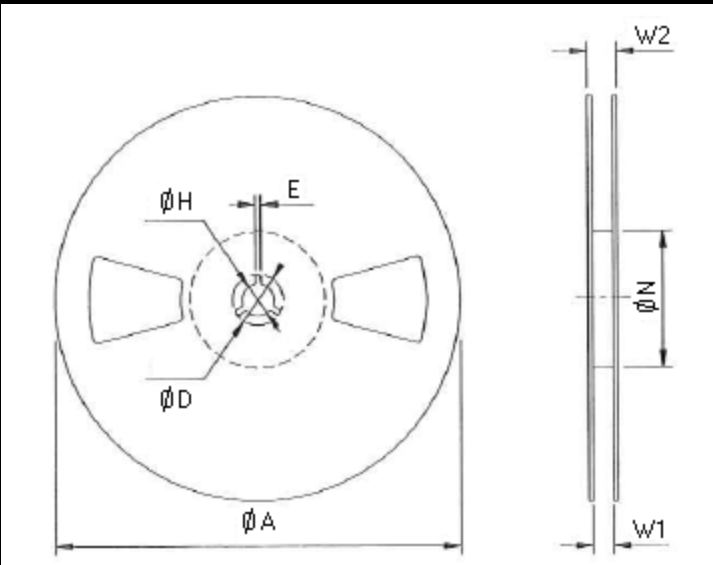

Dimension	Specification (mm)
A	180 +0/-3
N	60 +0/-1
W1	9.0 ±0.3
W2	13.0 ±1.4
D	21.0 ±0.8
H	13.0 ±0.2
E	2.0 ±0.5

Material : Plastic

Taping Orientation:

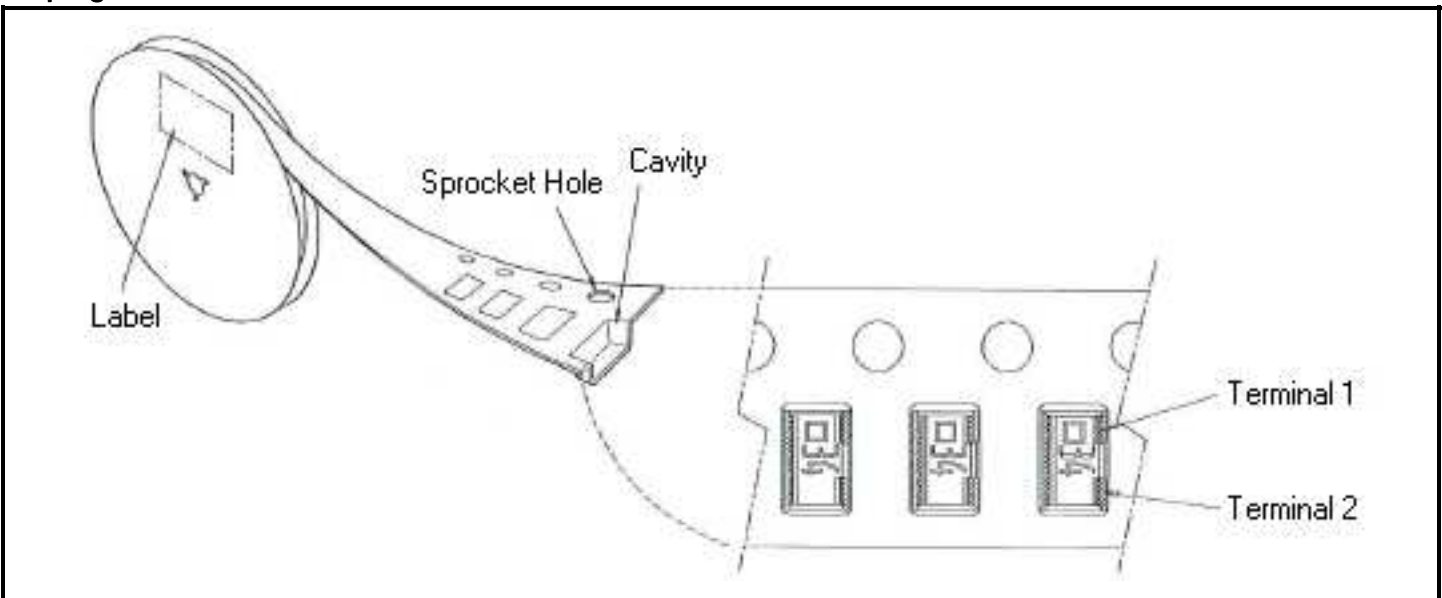

Recommended Reflow:

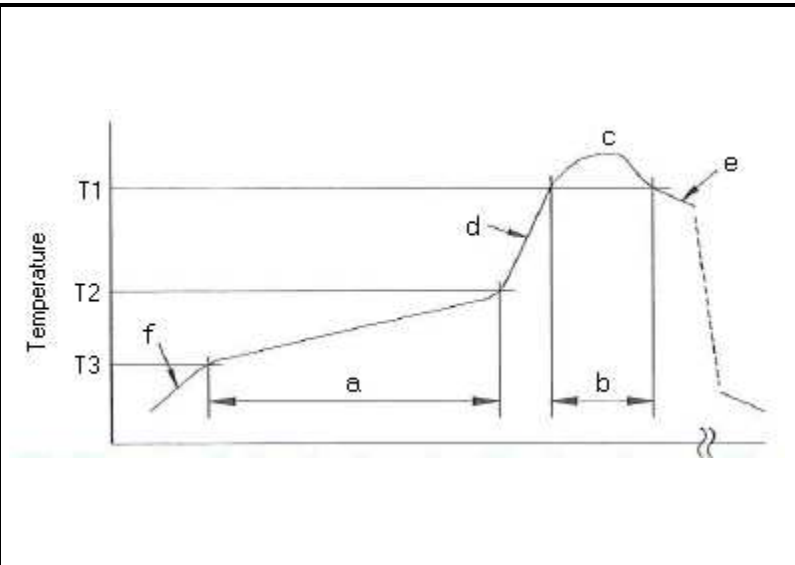

Parameter	Specification
T1	200°C
T2	140 ~ 170°C
T3	130 ±10°C
a (pre-heating)	40~150 seconds
b (heating)	10~60 seconds
c (peak)	Less than 250°C
d (change)	Less than 10°C/second
e (change)	Less than 8°C/second
f (change)	1~3°C/second

Note: Up to two reflows are allowed by recommended profile

Temperature Characteristics - 1dB Product:

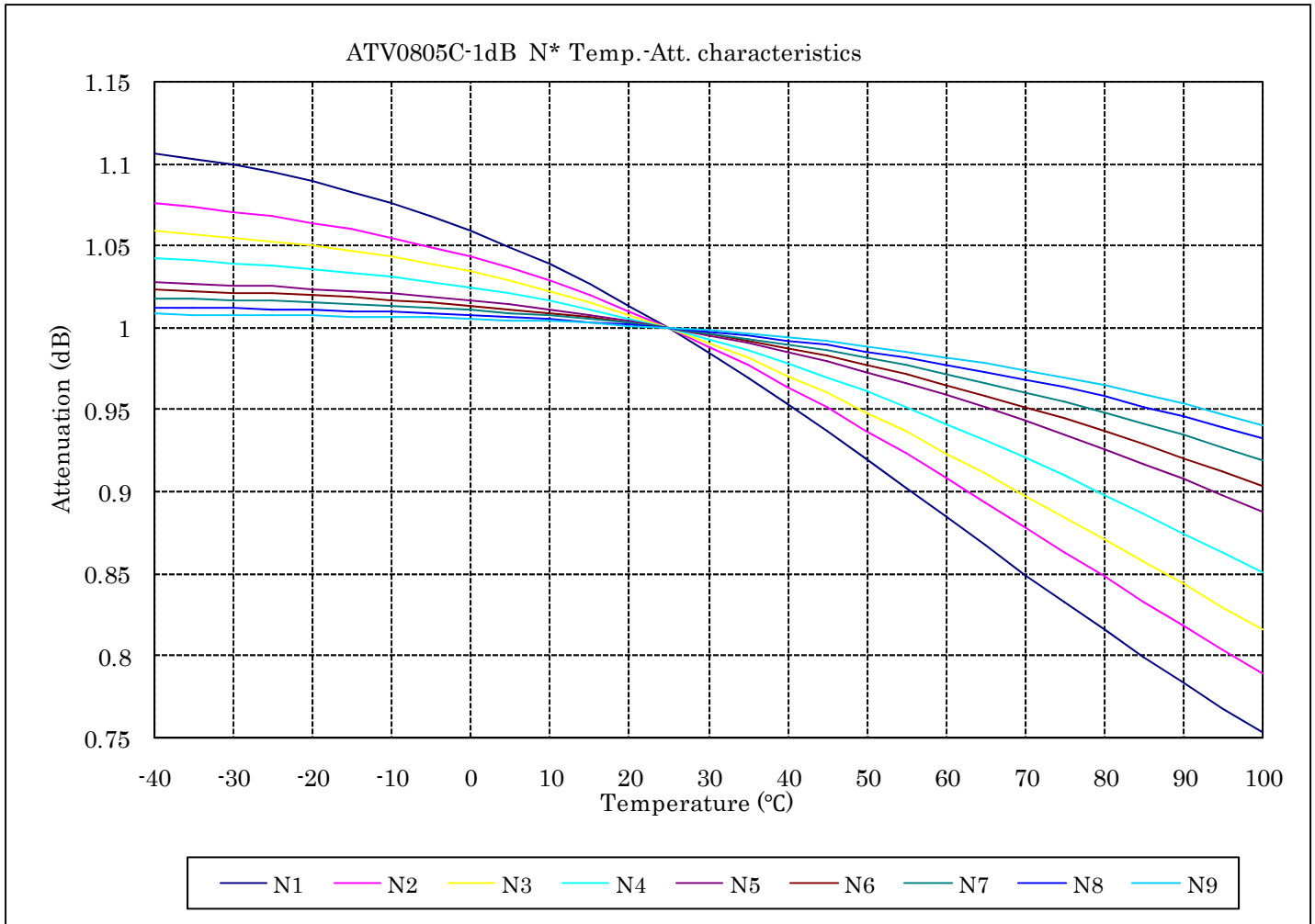

Attenuation at Temperatures Throughout Operating Temperature Range (1dB Product)

Temperature (°C)	N1	N2	N3	N4	N5	N6	N7	N8	N9
-40	1.106	1.076	1.059	1.042	1.028	1.023	1.018	1.013	1.008
-35	1.103	1.074	1.057	1.041	1.027	1.022	1.018	1.012	1.008
-30	1.099	1.071	1.055	1.040	1.026	1.022	1.017	1.012	1.008
-25	1.095	1.068	1.053	1.038	1.025	1.021	1.017	1.011	1.008
-20	1.090	1.064	1.050	1.036	1.024	1.020	1.016	1.011	1.008
-15	1.083	1.060	1.047	1.034	1.022	1.019	1.015	1.010	1.007
-10	1.077	1.055	1.043	1.031	1.021	1.017	1.014	1.010	1.007
-5	1.069	1.050	1.039	1.028	1.019	1.016	1.012	1.009	1.006
0	1.060	1.043	1.034	1.025	1.017	1.014	1.011	1.008	1.006
5	1.050	1.036	1.029	1.021	1.014	1.012	1.009	1.007	1.005
10	1.039	1.029	1.023	1.016	1.011	1.009	1.007	1.005	1.004
15	1.027	1.020	1.016	1.011	1.008	1.006	1.005	1.004	1.003
20	1.014	1.010	1.008	1.006	1.004	1.003	1.003	1.002	1.001
25	1.000	1.000	1.000	1.000	1.000	1.000	1.000	1.000	1.000
30	0.985	0.989	0.991	0.993	0.995	0.996	0.997	0.998	0.998
35	0.970	0.977	0.981	0.986	0.991	0.992	0.994	0.995	0.996
40	0.954	0.964	0.971	0.978	0.985	0.988	0.990	0.992	0.994
45	0.937	0.951	0.960	0.970	0.979	0.983	0.986	0.989	0.992
50	0.920	0.937	0.949	0.961	0.973	0.977	0.982	0.986	0.989
55	0.902	0.923	0.937	0.952	0.966	0.972	0.977	0.982	0.986
60	0.885	0.909	0.924	0.942	0.959	0.965	0.972	0.978	0.982
65	0.867	0.894	0.911	0.932	0.951	0.959	0.967	0.973	0.979
70	0.850	0.879	0.898	0.921	0.943	0.952	0.961	0.969	0.974
75	0.833	0.863	0.885	0.910	0.935	0.945	0.955	0.963	0.970
80	0.816	0.848	0.871	0.898	0.926	0.937	0.948	0.958	0.965
85	0.799	0.833	0.857	0.887	0.917	0.929	0.942	0.952	0.959
90	0.783	0.818	0.843	0.875	0.908	0.921	0.934	0.946	0.954
95	0.767	0.803	0.830	0.863	0.898	0.912	0.927	0.939	0.947
100	0.752	0.789	0.816	0.851	0.888	0.903	0.920	0.932	0.941

Temperature Characteristics - 2dB Product:

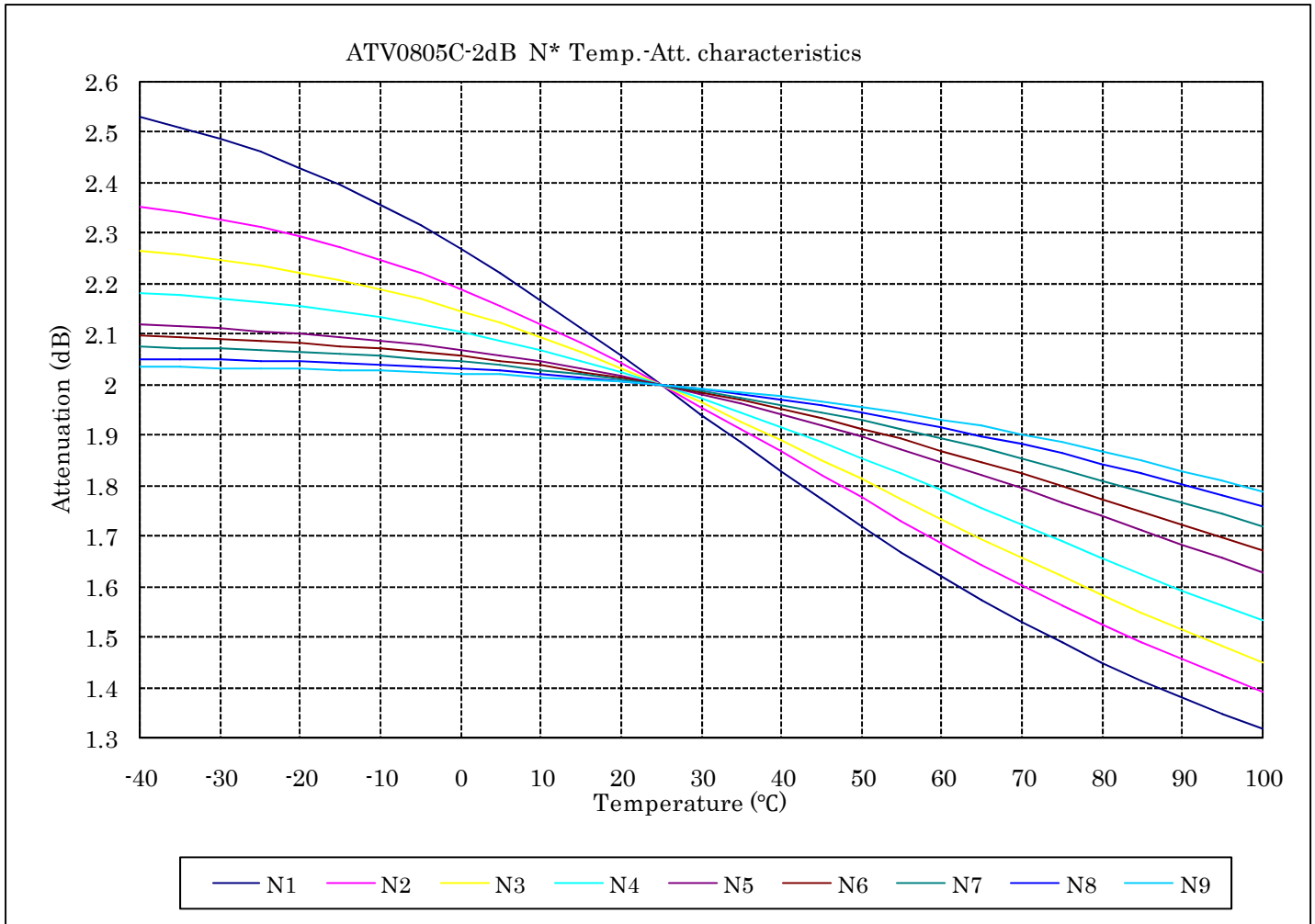

Attenuation at Temperatures Throughout Operating Temperature Range (2dB Product)

Temperature (°C)	N1	N2	N3	N4	N5	N6	N7	N8	N9
-40	2.531	2.354	2.265	2.183	2.118	2.096	2.076	2.051	2.034
-35	2.511	2.342	2.257	2.177	2.115	2.094	2.074	2.050	2.034
-30	2.488	2.328	2.247	2.171	2.111	2.091	2.071	2.049	2.033
-25	2.462	2.312	2.236	2.164	2.106	2.087	2.068	2.047	2.032
-20	2.431	2.293	2.222	2.155	2.101	2.082	2.065	2.045	2.031
-15	2.396	2.272	2.207	2.145	2.094	2.077	2.061	2.042	2.029
-10	2.358	2.247	2.189	2.133	2.087	2.071	2.056	2.039	2.027
-5	2.315	2.220	2.169	2.119	2.078	2.064	2.051	2.036	2.025
0	2.269	2.190	2.147	2.104	2.069	2.057	2.045	2.032	2.022
5	2.220	2.157	2.122	2.087	2.058	2.048	2.038	2.027	2.019
10	2.168	2.121	2.095	2.068	2.045	2.037	2.030	2.021	2.015
15	2.113	2.083	2.065	2.047	2.032	2.026	2.021	2.015	2.011
20	2.057	2.042	2.034	2.024	2.017	2.014	2.011	2.008	2.006
25	2.000	2.000	2.000	2.000	2.000	2.000	2.000	2.000	2.000
30	1.942	1.956	1.965	1.974	1.982	1.985	1.988	1.991	1.993
35	1.885	1.911	1.928	1.946	1.963	1.969	1.975	1.981	1.986
40	1.829	1.866	1.890	1.917	1.942	1.951	1.961	1.970	1.977
45	1.773	1.820	1.851	1.886	1.920	1.932	1.945	1.958	1.967
50	1.720	1.775	1.812	1.855	1.897	1.913	1.929	1.945	1.957
55	1.668	1.730	1.772	1.823	1.873	1.892	1.911	1.930	1.945
60	1.619	1.686	1.733	1.790	1.847	1.870	1.893	1.915	1.932
65	1.573	1.643	1.694	1.756	1.821	1.847	1.874	1.899	1.917
70	1.529	1.602	1.656	1.723	1.794	1.823	1.853	1.881	1.902
75	1.487	1.562	1.618	1.690	1.767	1.798	1.832	1.863	1.885
80	1.449	1.524	1.582	1.657	1.739	1.774	1.811	1.843	1.868
85	1.412	1.488	1.547	1.624	1.711	1.748	1.788	1.823	1.849
90	1.379	1.454	1.513	1.592	1.683	1.722	1.766	1.802	1.829
95	1.348	1.422	1.480	1.561	1.656	1.696	1.742	1.780	1.808
100	1.319	1.391	1.450	1.531	1.628	1.671	1.719	1.758	1.786

Temperature Characteristics - 3dB Product:

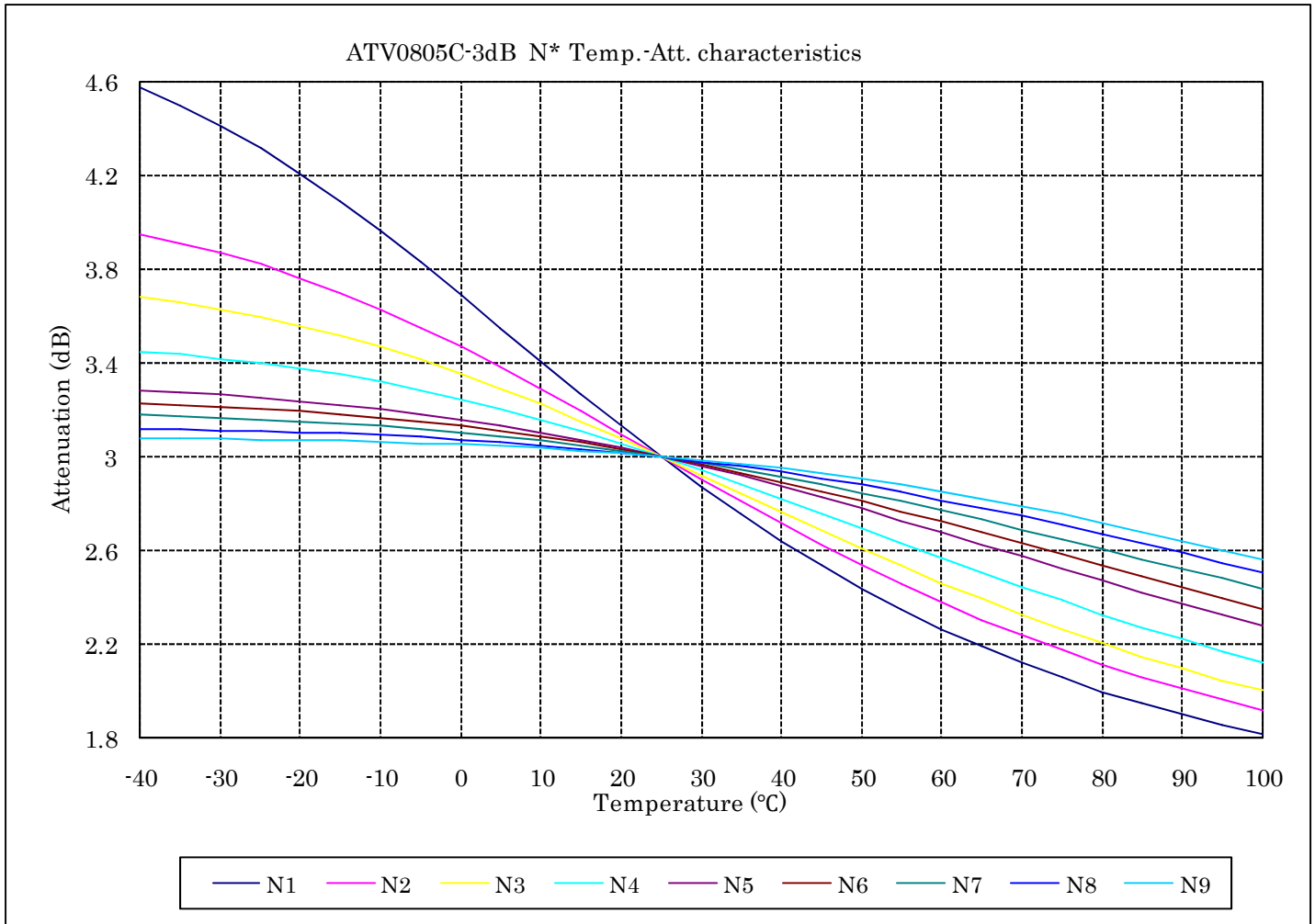

Attenuation at Temperatures Throughout Operating Temperature Range (3dB Product)

Temperature (°C)	N1	N2	N3	N4	N5	N6	N7	N8	N9
-40	4.577	3.950	3.680	3.450	3.281	3.228	3.177	3.119	3.079
-35	4.501	3.914	3.657	3.436	3.273	3.221	3.172	3.116	3.078
-30	4.415	3.871	3.629	3.419	3.263	3.214	3.167	3.113	3.076
-25	4.317	3.821	3.596	3.399	3.252	3.205	3.160	3.109	3.073
-20	4.209	3.764	3.558	3.376	3.238	3.194	3.151	3.104	3.070
-15	4.091	3.700	3.516	3.350	3.222	3.181	3.142	3.098	3.067
-10	3.964	3.629	3.467	3.319	3.204	3.167	3.131	3.091	3.063
-5	3.831	3.552	3.414	3.285	3.183	3.150	3.118	3.083	3.057
0	3.693	3.469	3.355	3.247	3.160	3.131	3.103	3.073	3.051
5	3.552	3.381	3.291	3.205	3.134	3.110	3.087	3.062	3.044
10	3.410	3.289	3.224	3.159	3.105	3.086	3.068	3.049	3.035
15	3.270	3.194	3.152	3.109	3.073	3.060	3.048	3.035	3.025
20	3.133	3.098	3.077	3.056	3.038	3.031	3.025	3.018	3.013
25	3.000	3.000	3.000	3.000	3.000	3.000	3.000	3.000	3.000
30	2.873	2.903	2.921	2.941	2.960	2.966	2.973	2.980	2.985
35	2.753	2.807	2.842	2.881	2.917	2.930	2.944	2.957	2.968
40	2.640	2.714	2.763	2.819	2.872	2.892	2.912	2.933	2.948
45	2.534	2.624	2.684	2.755	2.825	2.852	2.879	2.906	2.927
50	2.436	2.537	2.607	2.692	2.777	2.810	2.844	2.878	2.903
55	2.346	2.455	2.533	2.628	2.727	2.766	2.807	2.847	2.878
60	2.263	2.377	2.460	2.565	2.676	2.721	2.769	2.815	2.850
65	2.188	2.304	2.391	2.503	2.625	2.675	2.729	2.780	2.820
70	2.118	2.235	2.325	2.442	2.574	2.629	2.689	2.745	2.787
75	2.055	2.171	2.262	2.383	2.523	2.582	2.647	2.707	2.753
80	1.998	2.112	2.202	2.326	2.472	2.535	2.605	2.669	2.717
85	1.946	2.057	2.146	2.271	2.421	2.488	2.562	2.629	2.679
90	1.899	2.006	2.094	2.219	2.372	2.441	2.520	2.588	2.640
95	1.856	1.959	2.045	2.169	2.324	2.395	2.477	2.547	2.600
100	1.817	1.916	1.999	2.121	2.278	2.350	2.435	2.506	2.558

Temperature Characteristics - 4dB Product:

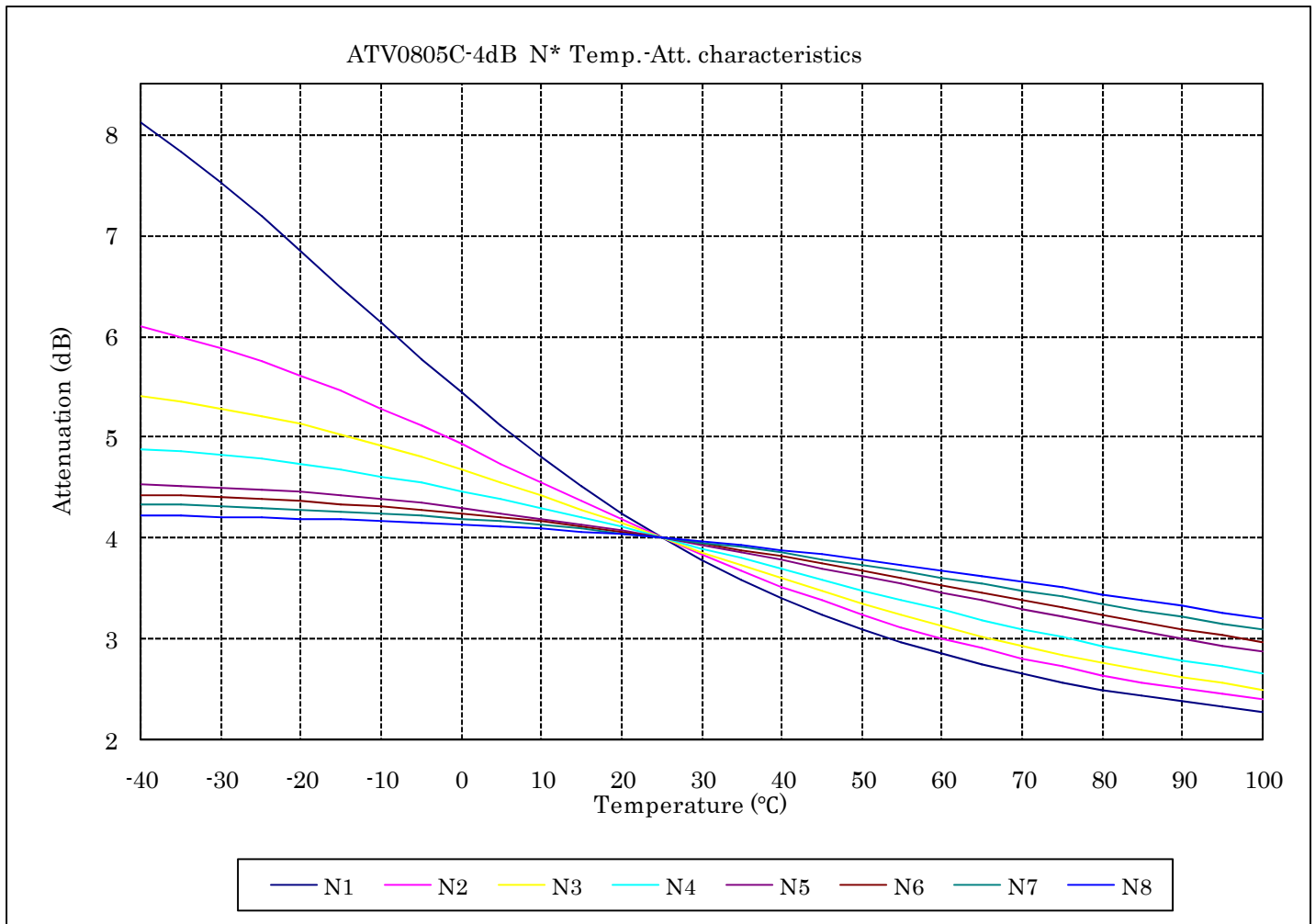

Attenuation at Temperatures Throughout Operating Temperature Range (4dB Product)

Temperature (°C)	N1	N2	N3	N4	N5	N6	N7	N8
-40	8.117	6.092	5.405	4.884	4.533	4.427	4.329	4.218
-35	7.833	5.993	5.349	4.854	4.517	4.414	4.319	4.213
-30	7.522	5.880	5.284	4.818	4.497	4.399	4.308	4.207
-25	7.190	5.751	5.208	4.776	4.474	4.382	4.295	4.199
-20	6.843	5.608	5.122	4.727	4.447	4.361	4.279	4.190
-15	6.487	5.452	5.026	4.672	4.416	4.336	4.261	4.179
-10	6.130	5.285	4.921	4.610	4.381	4.309	4.240	4.166
-5	5.777	5.109	4.806	4.540	4.341	4.277	4.216	4.150
0	5.435	4.925	4.683	4.464	4.296	4.241	4.189	4.133
5	5.108	4.738	4.553	4.382	4.246	4.201	4.158	4.112
10	4.799	4.549	4.419	4.293	4.191	4.157	4.124	4.089
15	4.510	4.362	4.280	4.199	4.132	4.109	4.086	4.062
20	4.244	4.178	4.140	4.101	4.068	4.056	4.045	4.033
25	4.000	4.000	4.000	4.000	4.000	4.000	4.000	4.000
30	3.778	3.829	3.861	3.896	3.928	3.940	3.952	3.964
35	3.577	3.667	3.725	3.791	3.854	3.877	3.900	3.924
40	3.396	3.514	3.594	3.686	3.776	3.810	3.846	3.881
45	3.234	3.371	3.467	3.581	3.697	3.742	3.788	3.835
50	3.089	3.239	3.346	3.479	3.617	3.671	3.729	3.786
55	2.959	3.116	3.232	3.378	3.535	3.599	3.667	3.734
60	2.843	3.003	3.124	3.281	3.454	3.526	3.604	3.679
65	2.740	2.899	3.023	3.187	3.374	3.452	3.539	3.623
70	2.648	2.804	2.928	3.097	3.294	3.379	3.474	3.564
75	2.566	2.718	2.841	3.011	3.216	3.306	3.408	3.503
80	2.493	2.639	2.760	2.930	3.140	3.234	3.342	3.442
85	2.428	2.568	2.685	2.854	3.067	3.164	3.277	3.379
90	2.369	2.503	2.616	2.782	2.996	3.095	3.212	3.317
95	2.317	2.444	2.553	2.715	2.928	3.029	3.149	3.254
100	2.270	2.390	2.495	2.652	2.863	2.964	3.086	3.191

Temperature Characteristics - 5dB Product:

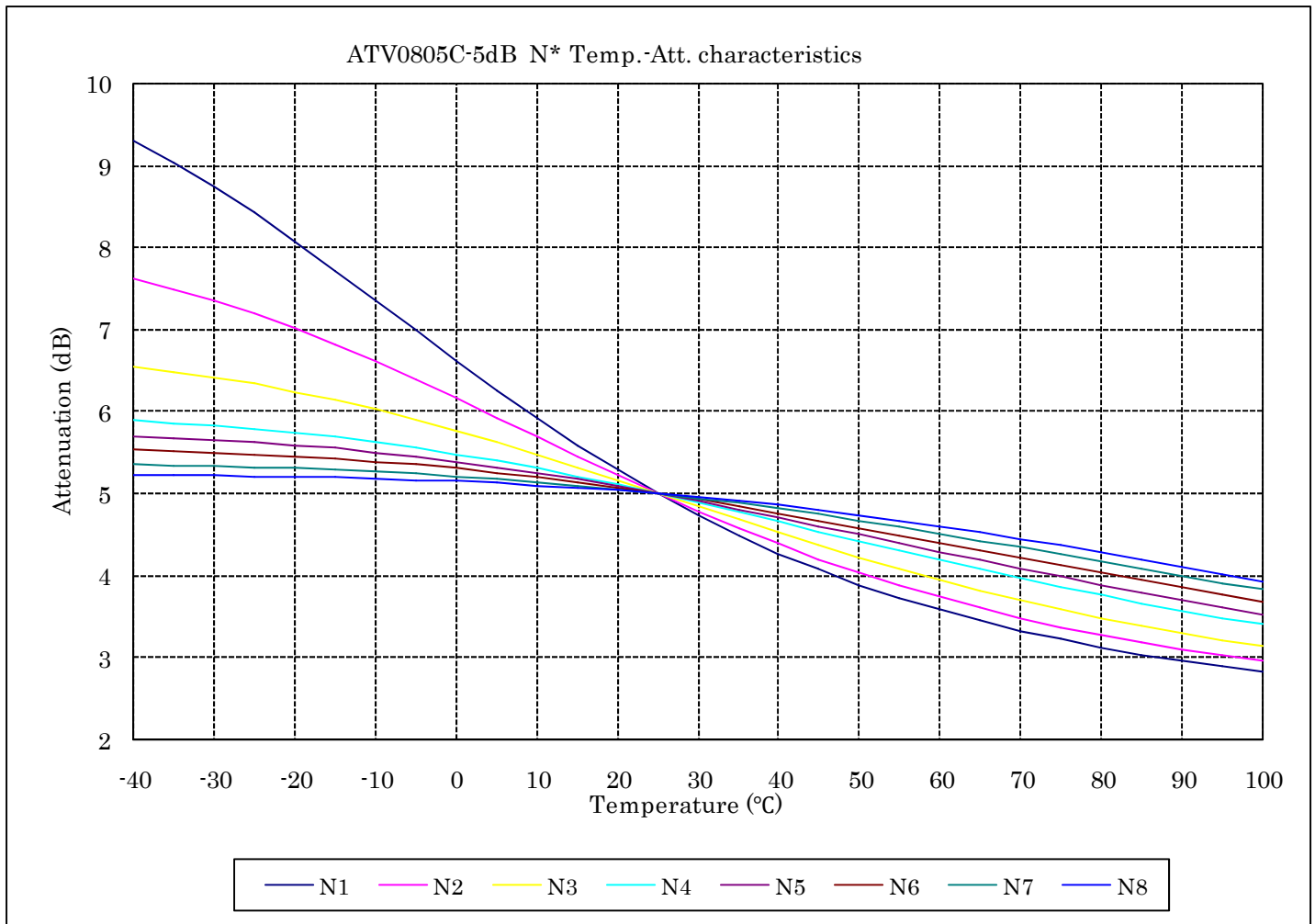

Attenuation at Temperatures Throughout Operating Temperature Range (5dB Product)

Temperature (°C)	N1	N2	N3	N4	N5	N6	N7	N8
-40	9.307	7.620	6.542	5.892	5.706	5.538	5.353	5.230
-35	9.042	7.497	6.484	5.863	5.684	5.522	5.344	5.226
-30	8.747	7.356	6.415	5.829	5.658	5.503	5.334	5.220
-25	8.426	7.195	6.336	5.788	5.628	5.481	5.321	5.213
-20	8.084	7.017	6.245	5.742	5.592	5.455	5.306	5.205
-15	7.726	6.823	6.143	5.688	5.551	5.424	5.287	5.194
-10	7.359	6.614	6.030	5.627	5.504	5.389	5.266	5.181
-5	6.989	6.393	5.905	5.558	5.450	5.349	5.241	5.166
0	6.623	6.163	5.771	5.482	5.391	5.304	5.212	5.148
5	6.265	5.928	5.628	5.399	5.324	5.254	5.179	5.126
10	5.921	5.692	5.478	5.308	5.252	5.198	5.141	5.101
15	5.594	5.456	5.322	5.211	5.174	5.137	5.099	5.071
20	5.286	5.225	5.162	5.108	5.089	5.071	5.052	5.038
25	5.000	5.000	5.000	5.000	5.000	5.000	5.000	5.000
30	4.735	4.784	4.838	4.888	4.906	4.924	4.943	4.957
35	4.492	4.579	4.678	4.773	4.808	4.844	4.881	4.910
40	4.271	4.385	4.520	4.655	4.707	4.760	4.815	4.857
45	4.070	4.204	4.368	4.537	4.603	4.673	4.744	4.799
50	3.888	4.035	4.220	4.419	4.498	4.584	4.670	4.737
55	3.723	3.878	4.079	4.301	4.393	4.493	4.592	4.670
60	3.576	3.734	3.945	4.186	4.287	4.400	4.511	4.598
65	3.443	3.601	3.818	4.073	4.183	4.307	4.427	4.523
70	3.324	3.480	3.699	3.963	4.080	4.213	4.342	4.444
75	3.217	3.369	3.587	3.858	3.980	4.121	4.255	4.362
80	3.121	3.268	3.483	3.756	3.882	4.029	4.168	4.278
85	3.035	3.176	3.386	3.659	3.787	3.940	4.081	4.192
90	2.957	3.093	3.296	3.567	3.696	3.852	3.994	4.106
95	2.888	3.017	3.213	3.479	3.609	3.767	3.908	4.018
100	2.825	2.948	3.136	3.397	3.526	3.684	3.824	3.931

Temperature Characteristics - 6dB Product:

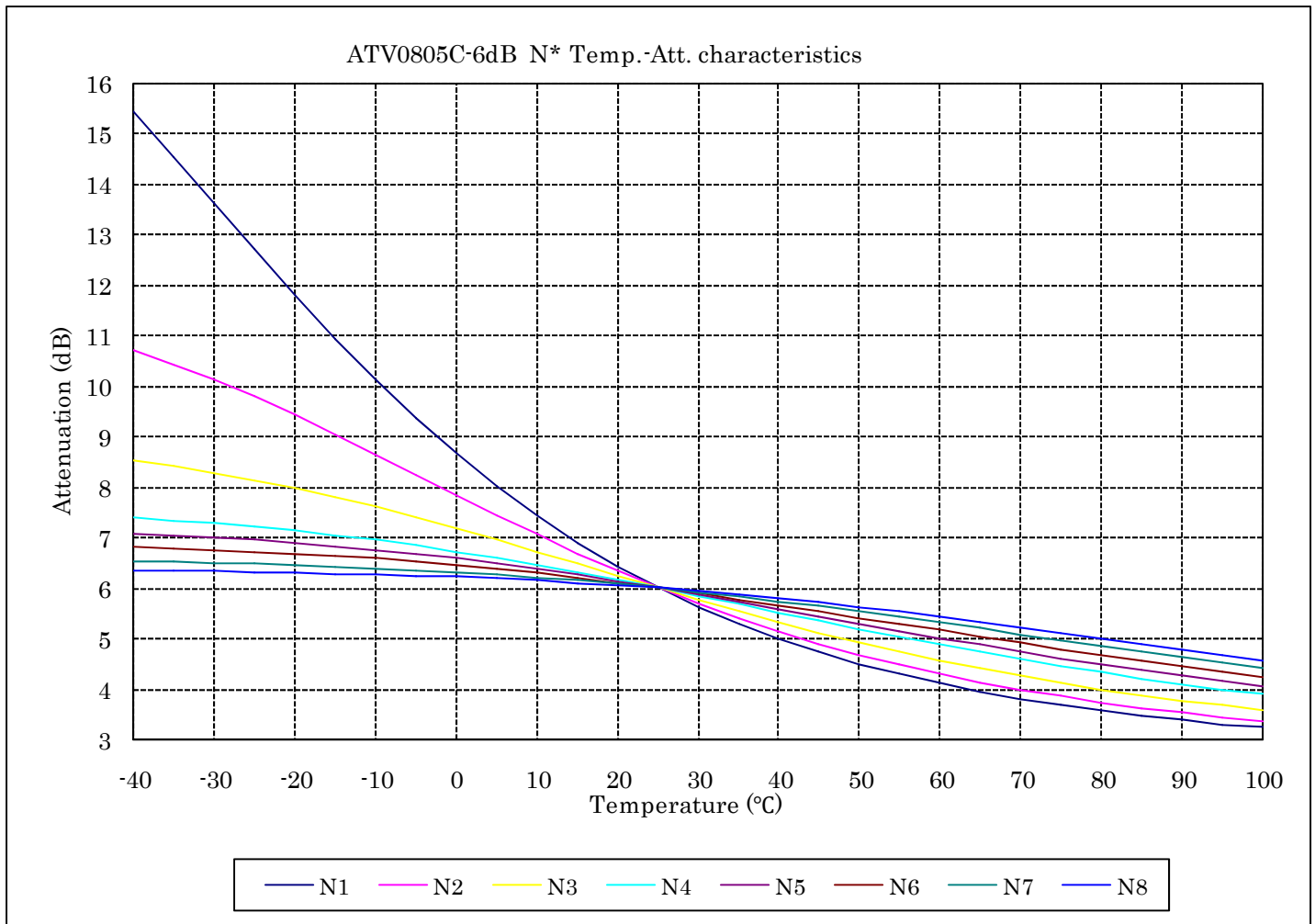

Attenuation at Temperatures Throughout Operating Temperature Range (6dB Product)

Temperature (°C)	N1	N2	N3	N4	N5	N6	N7	N8
-40	15.444	10.713	8.520	7.385	7.081	6.814	6.526	6.341
-35	14.541	10.438	8.413	7.337	7.046	6.789	6.513	6.334
-30	13.622	10.131	8.289	7.281	7.005	6.759	6.498	6.326
-25	12.708	9.794	8.147	7.215	6.956	6.724	6.478	6.315
-20	11.814	9.431	7.987	7.139	6.899	6.684	6.455	6.303
-15	10.953	9.049	7.809	7.052	6.834	6.636	6.427	6.287
-10	10.138	8.652	7.615	6.954	6.760	6.582	6.395	6.268
-5	9.375	8.248	7.407	6.846	6.677	6.521	6.357	6.245
0	8.669	7.844	7.186	6.726	6.585	6.452	6.314	6.217
5	8.022	7.446	6.956	6.597	6.484	6.376	6.264	6.185
10	7.434	7.058	6.719	6.459	6.374	6.293	6.208	6.148
15	6.902	6.686	6.479	6.312	6.256	6.202	6.145	6.105
20	6.426	6.332	6.238	6.159	6.131	6.104	6.076	6.056
25	6.000	6.000	6.000	6.000	6.000	6.000	6.000	6.000
30	5.621	5.690	5.767	5.838	5.864	5.890	5.917	5.938
35	5.285	5.403	5.540	5.674	5.724	5.775	5.829	5.869
40	4.987	5.139	5.323	5.509	5.581	5.656	5.734	5.794
45	4.723	4.898	5.116	5.345	5.437	5.534	5.634	5.711
50	4.490	4.678	4.920	5.184	5.293	5.410	5.529	5.623
55	4.285	4.478	4.735	5.027	5.150	5.285	5.421	5.529
60	4.103	4.298	4.563	4.874	5.009	5.159	5.310	5.430
65	3.942	4.134	4.403	4.727	4.871	5.034	5.196	5.326
70	3.800	3.987	4.254	4.587	4.737	4.911	5.081	5.219
75	3.674	3.854	4.117	4.452	4.608	4.789	4.966	5.109
80	3.562	3.735	3.990	4.325	4.483	4.671	4.851	4.996
85	3.463	3.627	3.874	4.205	4.364	4.556	4.738	4.883
90	3.375	3.530	3.767	4.092	4.251	4.445	4.626	4.770
95	3.297	3.443	3.669	3.986	4.144	4.339	4.517	4.657
100	3.226	3.364	3.580	3.887	4.042	4.236	4.410	4.546

Temperature Characteristics - 7dB Product:

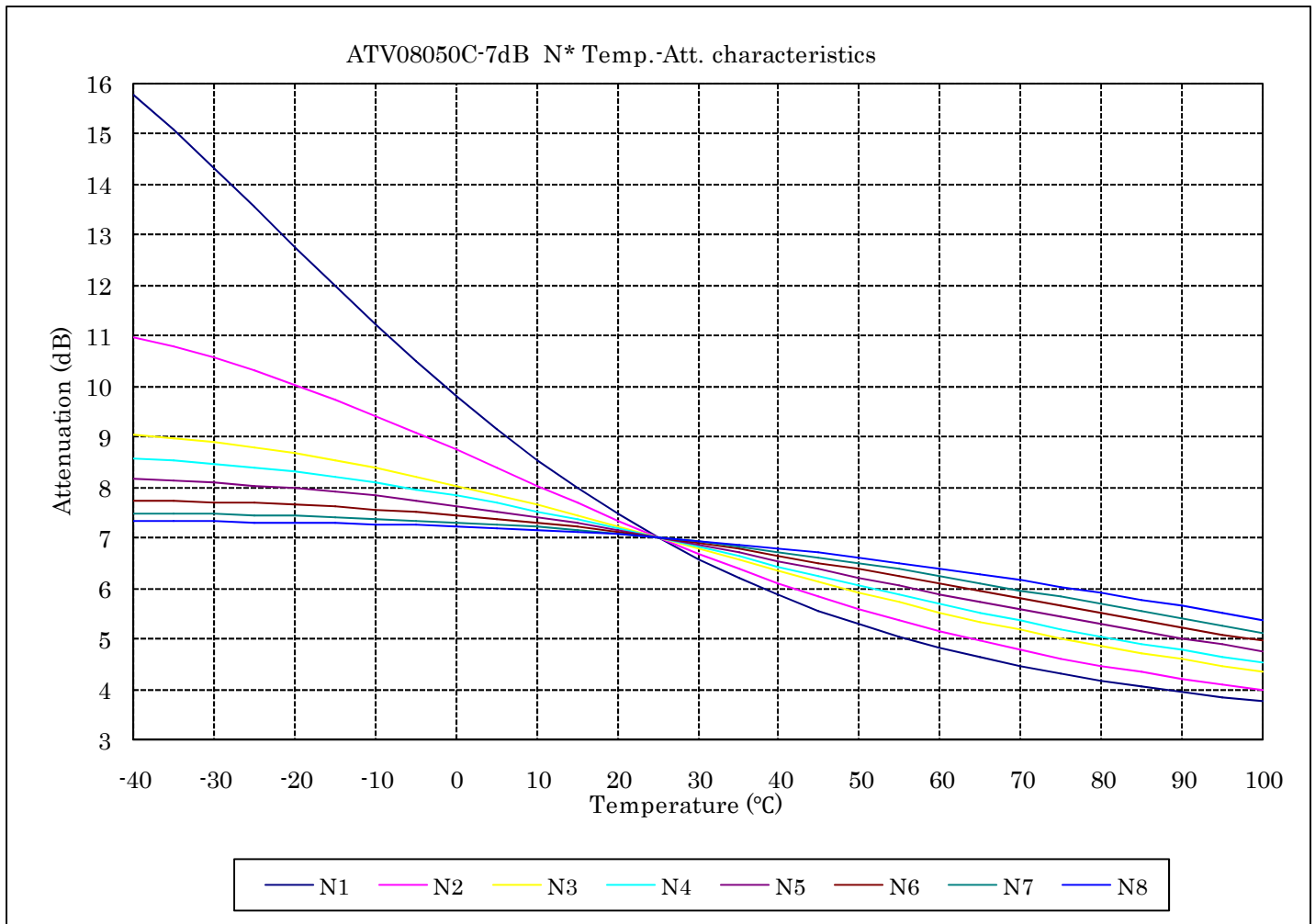

Attenuation at Temperatures Throughout Operating Temperature Range (7dB Product)

Temperature (°C)	N1	N2	N3	N4	N5	N6	N7	N8
-40	15.794	10.986	9.050	8.575	8.169	7.746	7.478	7.327
-35	15.081	10.792	8.975	8.521	8.132	7.727	7.469	7.321
-30	14.329	10.569	8.886	8.458	8.088	7.704	7.457	7.314
-25	13.554	10.319	8.783	8.384	8.036	7.676	7.442	7.305
-20	12.770	10.043	8.664	8.298	7.976	7.642	7.424	7.293
-15	11.991	9.743	8.530	8.200	7.906	7.602	7.401	7.279
-10	11.230	9.422	8.381	8.089	7.827	7.556	7.374	7.261
-5	10.498	9.086	8.217	7.966	7.738	7.502	7.342	7.239
0	9.802	8.738	8.039	7.831	7.638	7.440	7.303	7.214
5	9.148	8.384	7.849	7.683	7.529	7.369	7.258	7.183
10	8.540	8.029	7.647	7.525	7.410	7.290	7.205	7.147
15	7.979	7.677	7.437	7.358	7.281	7.202	7.145	7.105
20	7.466	7.333	7.221	7.182	7.144	7.105	7.077	7.056
25	7.000	7.000	7.000	7.000	7.000	7.000	7.000	7.000
30	6.578	6.681	6.778	6.813	6.849	6.886	6.914	6.937
35	6.198	6.379	6.556	6.623	6.693	6.765	6.820	6.866
40	5.857	6.094	6.337	6.432	6.533	6.637	6.718	6.787
45	5.552	5.827	6.123	6.242	6.371	6.503	6.607	6.700
50	5.280	5.579	5.915	6.055	6.207	6.364	6.489	6.605
55	5.036	5.350	5.715	5.870	6.044	6.222	6.364	6.503
60	4.820	5.139	5.523	5.691	5.883	6.077	6.233	6.394
65	4.626	4.945	5.340	5.518	5.724	5.930	6.098	6.278
70	4.454	4.768	5.168	5.352	5.568	5.783	5.959	6.157
75	4.301	4.605	5.005	5.193	5.417	5.638	5.818	6.031
80	4.164	4.458	4.852	5.042	5.271	5.494	5.676	5.902
85	4.042	4.323	4.710	4.899	5.131	5.353	5.534	5.770
90	3.933	4.201	4.577	4.764	4.996	5.216	5.393	5.636
95	3.835	4.090	4.453	4.637	4.868	5.083	5.254	5.502
100	3.748	3.989	4.339	4.519	4.747	4.954	5.118	5.369

Temperature Characteristics - 8dB Product:

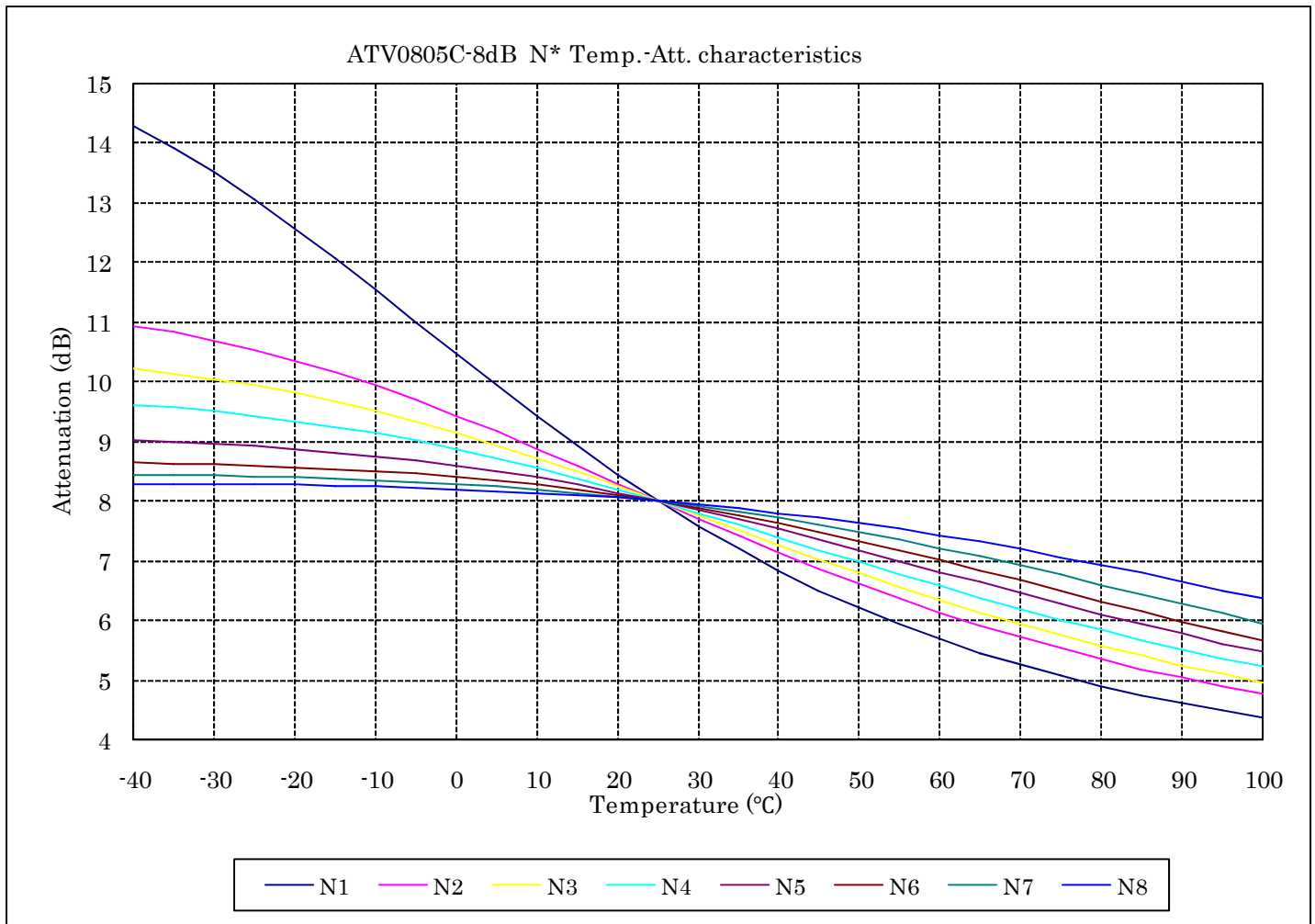

Attenuation at Temperatures Throughout Operating Temperature Range (8dB Product)

Temperature (°C)	N1	N2	N3	N4	N5	N6	N7	N8
-40	14.294	10.947	10.219	9.621	9.017	8.646	8.439	8.295
-35	13.924	10.829	10.139	9.567	8.991	8.633	8.431	8.290
-30	13.512	10.692	10.045	9.504	8.958	8.617	8.421	8.284
-25	13.061	10.533	9.935	9.429	8.919	8.596	8.409	8.275
-20	12.577	10.354	9.808	9.343	8.872	8.571	8.393	8.265
-15	12.067	10.152	9.665	9.244	8.817	8.540	8.374	8.252
-10	11.539	9.931	9.505	9.132	8.753	8.503	8.350	8.237
-5	11.003	9.691	9.329	9.006	8.678	8.459	8.321	8.217
0	10.466	9.433	9.137	8.867	8.593	8.407	8.286	8.194
5	9.935	9.162	8.930	8.716	8.497	8.345	8.245	8.167
10	9.419	8.880	8.711	8.552	8.389	8.275	8.196	8.134
15	8.921	8.590	8.481	8.377	8.270	8.194	8.139	8.096
20	8.447	8.295	8.243	8.193	8.140	8.102	8.074	8.051
25	8.000	8.000	8.000	8.000	8.000	8.000	8.000	8.000
30	7.581	7.707	7.753	7.801	7.850	7.887	7.916	7.942
35	7.192	7.420	7.506	7.597	7.691	7.763	7.823	7.875
40	6.833	7.140	7.261	7.390	7.524	7.629	7.719	7.801
45	6.503	6.870	7.020	7.182	7.351	7.485	7.606	7.719
50	6.201	6.611	6.784	6.976	7.174	7.333	7.483	7.629
55	5.926	6.365	6.556	6.771	6.994	7.174	7.351	7.530
60	5.675	6.133	6.337	6.571	6.812	7.008	7.212	7.424
65	5.448	5.914	6.127	6.376	6.630	6.839	7.065	7.309
70	5.243	5.709	5.928	6.187	6.449	6.666	6.913	7.188
75	5.057	5.518	5.740	6.006	6.272	6.492	6.756	7.061
80	4.889	5.341	5.562	5.832	6.098	6.318	6.595	6.928
85	4.738	5.177	5.395	5.666	5.929	6.146	6.433	6.790
90	4.601	5.024	5.239	5.508	5.766	5.976	6.270	6.649
95	4.477	4.884	5.094	5.359	5.609	5.811	6.108	6.505
100	4.365	4.755	4.958	5.219	5.459	5.651	5.948	6.360

Temperature Characteristics - 9dB Product:

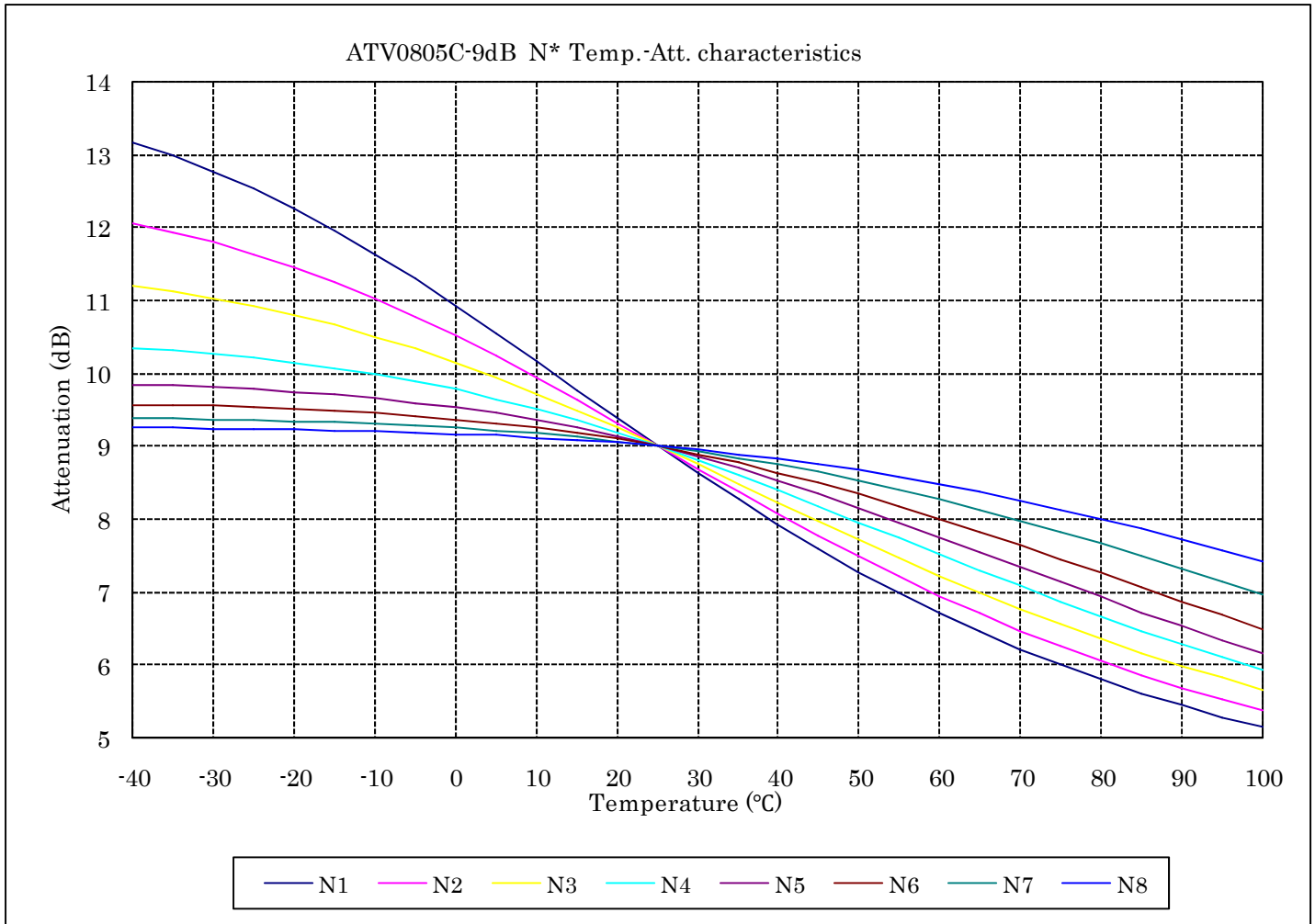

Attenuation at Temperatures Throughout Operating Temperature Range (9dB Product)

Temperature (°C)	N1	N2	N3	N4	N5	N6	N7	N8
-40	13.172	12.062	11.192	10.350	9.848	9.573	9.384	9.255
-35	12.988	11.943	11.117	10.314	9.831	9.563	9.377	9.251
-30	12.775	11.804	11.027	10.270	9.809	9.550	9.369	9.246
-25	12.533	11.644	10.922	10.217	9.782	9.533	9.358	9.239
-20	12.262	11.461	10.801	10.153	9.748	9.512	9.344	9.230
-15	11.963	11.256	10.663	10.078	9.708	9.487	9.328	9.219
-10	11.638	11.029	10.508	9.991	9.658	9.455	9.307	9.206
-5	11.292	10.781	10.335	9.891	9.599	9.417	9.282	9.189
0	10.928	10.515	10.147	9.777	9.530	9.371	9.252	9.169
5	10.550	10.232	9.942	9.649	9.450	9.317	9.216	9.146
10	10.163	9.935	9.723	9.507	9.357	9.254	9.173	9.117
15	9.773	9.629	9.492	9.351	9.251	9.180	9.124	9.084
20	9.384	9.316	9.250	9.182	9.132	9.096	9.066	9.045
25	9.000	9.000	9.000	9.000	9.000	9.000	9.000	9.000
30	8.625	8.684	8.744	8.807	8.855	8.892	8.925	8.948
35	8.263	8.372	8.486	8.605	8.696	8.772	8.840	8.889
40	7.916	8.066	8.226	8.394	8.526	8.640	8.745	8.823
45	7.586	7.769	7.969	8.178	8.346	8.497	8.641	8.748
50	7.273	7.482	7.715	7.958	8.156	8.343	8.526	8.666
55	6.980	7.208	7.467	7.737	7.958	8.178	8.402	8.575
60	6.706	6.947	7.226	7.515	7.755	8.005	8.268	8.475
65	6.451	6.699	6.993	7.296	7.548	7.824	8.126	8.368
70	6.214	6.467	6.770	7.080	7.339	7.638	7.976	8.252
75	5.995	6.249	6.557	6.869	7.131	7.447	7.819	8.129
80	5.793	6.045	6.355	6.665	6.924	7.254	7.656	7.998
85	5.608	5.855	6.164	6.468	6.721	7.060	7.489	7.862
90	5.438	5.678	5.984	6.279	6.523	6.867	7.319	7.720
95	5.281	5.515	5.814	6.099	6.331	6.677	7.147	7.573
100	5.138	5.364	5.656	5.928	6.146	6.490	6.974	7.422

Temperature Characteristics - 10dB Product:

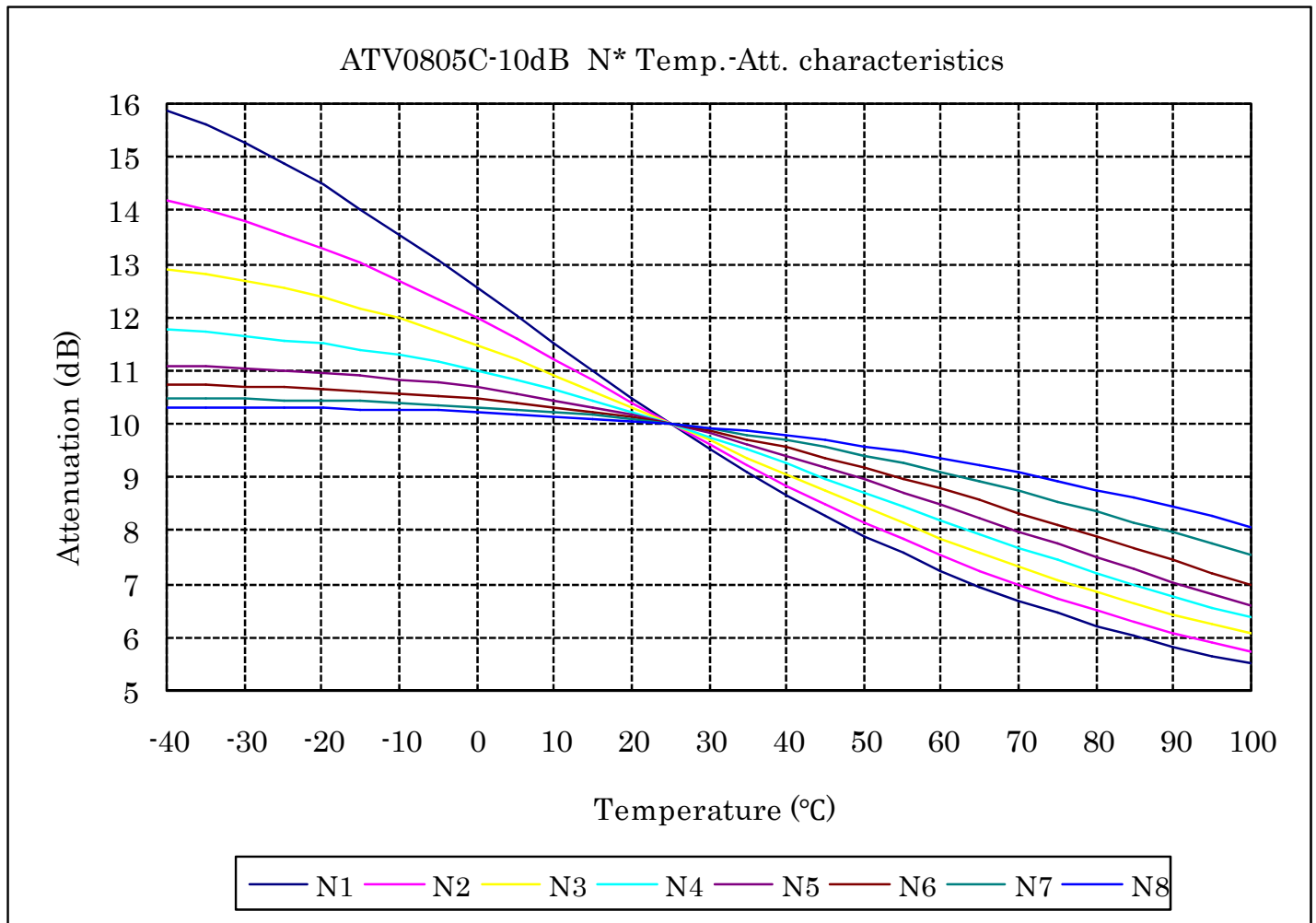

Attenuation at Temperatures Throughout Operating Temperature Range (10dB Product)

Temperature (°C)	N1	N2	N3	N4	N5	N6	N7	N8
-40	15.900	14.178	12.918	11.757	11.091	10.732	10.488	10.324
-35	15.605	14.002	12.811	11.709	11.068	10.719	10.479	10.318
-30	15.269	13.797	12.685	11.650	11.039	10.702	10.468	10.311
-25	14.892	13.563	12.539	11.578	11.004	10.680	10.455	10.302
-20	14.478	13.300	12.371	11.494	10.960	10.653	10.437	10.291
-15	14.031	13.007	12.182	11.394	10.906	10.620	10.416	10.277
-10	13.556	12.688	11.970	11.279	10.842	10.580	10.390	10.260
-5	13.059	12.344	11.737	11.147	10.766	10.531	10.358	10.239
0	12.547	11.980	11.485	10.998	10.676	10.472	10.319	10.214
5	12.027	11.598	11.214	10.831	10.573	10.403	10.273	10.184
10	11.507	11.205	10.927	10.647	10.453	10.322	10.219	10.148
15	10.992	10.804	10.627	10.446	10.318	10.228	10.156	10.106
20	10.488	10.401	10.317	10.230	10.167	10.121	10.083	10.057
25	10.000	10.000	10.000	10.000	10.000	10.000	10.000	10.000
30	9.532	9.605	9.680	9.758	9.817	9.864	9.905	9.935
35	9.086	9.219	9.359	9.506	9.620	9.715	9.799	9.861
40	8.666	8.847	9.042	9.247	9.409	9.551	9.681	9.778
45	8.271	8.489	8.729	8.983	9.187	9.373	9.551	9.685
50	7.902	8.148	8.425	8.717	8.955	9.184	9.409	9.582
55	7.560	7.825	8.130	8.451	8.716	8.983	9.256	9.469
60	7.243	7.521	7.846	8.187	8.472	8.773	9.093	9.346
65	6.951	7.236	7.575	7.928	8.226	8.556	8.919	9.214
70	6.683	6.970	7.317	7.676	7.980	8.333	8.738	9.073
75	6.437	6.722	7.073	7.432	7.735	8.107	8.549	8.923
80	6.212	6.493	6.843	7.196	7.495	7.880	8.355	8.765
85	6.006	6.280	6.627	6.971	7.261	7.653	8.156	8.600
90	5.819	6.084	6.424	6.757	7.034	7.429	7.955	8.430
95	5.647	5.904	6.235	6.553	6.816	7.210	7.754	8.255
100	5.491	5.737	6.059	6.362	6.607	6.996	7.553	8.077