

Product Family: [20 Watt RF Chip Power Resistor](#)

Part Number Series: [CFN2010 Series](#)

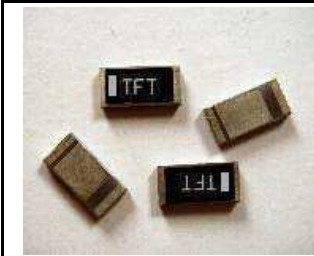

Construction:

- Aluminum nitride substrate
- Nickel alloy thin-film resistive element
- Epoxy-resin overcoat
- Pre-tinned (Sn100, matte) terminations over Ni barrier is standard (RoHS compliant and Pb Free)

Features:

- TCR = ± 25 ppm/ $^{\circ}$ C
- Extended frequency performance
- High volume production suitable for commercial and special applications
- Competitive pricing

Description:

These aluminum nitride chip power resistors are designed to tolerate high current and establish a low thermal resistance interface with the circuit board. A lower thermal resistance more efficiently sinks heat to the board providing a larger effective area for heat dissipation which enables the chip to sustain higher power levels. These power resistors are primarily used in microwave power amplifiers, and power attenuators. Low temperature coefficients, high power handling, long term stability and extended frequency performance make these chip resistors ideal for use in telecommunication applications.

Product Dimensions:

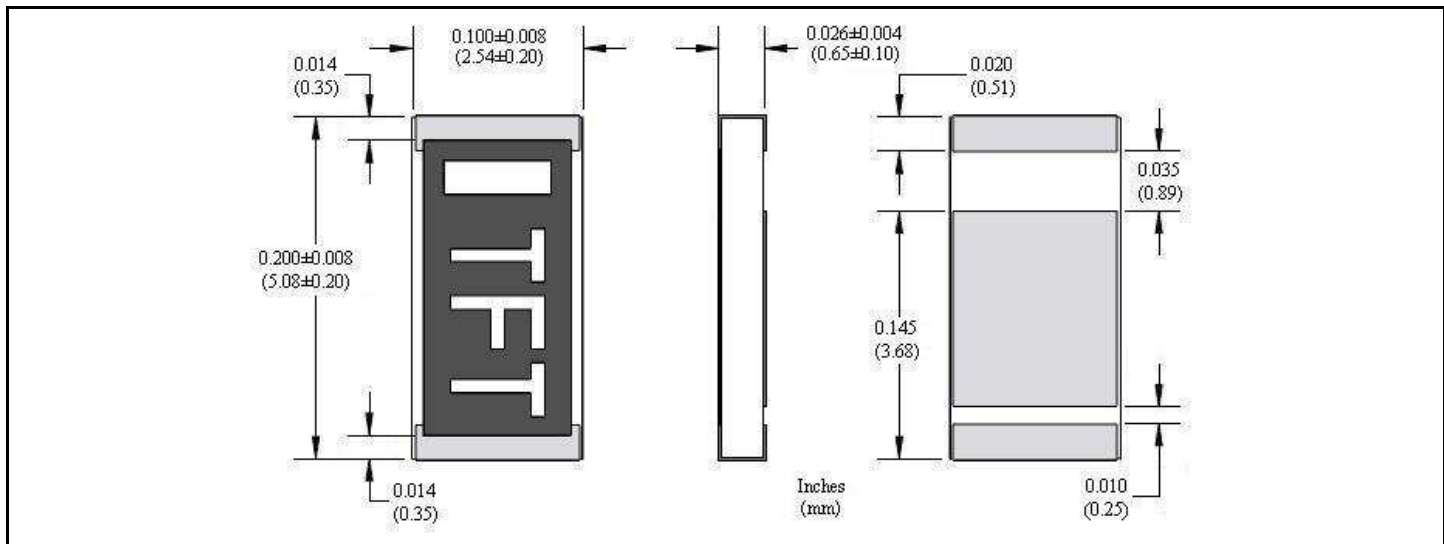

Recommended Land Pattern:

Please refer to the following page.

Part Numbering: CFN2010E50R0JS*

Product Designator	Ceramic Type	English Size (Metric Size)	Temp. Coefficient of Resistance (TCR)	Resistance Value	Tolerance	Custom Code
CF	N = Aluminum Nitride	2010 (5025)	E = ± 25 ppc/ $^{\circ}$ C	50R0 = 50.0 Ω	J = $\pm 5\%$	S = Standard

*Note: T&R package quantity (-T##) will be appended by us to the end of the part number. Refer to the following page for standard package sizes.

Electrical Specifications:

Type	CFN2010E50R0JS*
English Size	2010
Metric Size	5025
Power	20 Watts
Rated Voltage	$\sqrt{\text{Power} \times \text{Resistance}}$ (31.6 volts)
Frequency Performance	Return Loss < 21dB to 2.0GHz Max VSWR = 1.20 to 2.0GHz
Resistance	50Ω
Tolerance% (code)	±5.0% (J)
TCR ppm/°C (code)	±25ppm/°C (E)
Operating Temperature	-55°C ~ +150°C
Packaging	1,000 or 5,000 pcs/reel

Please consult the factory for any desired variations to the above specifications

Frequency Performance Plot (typical):

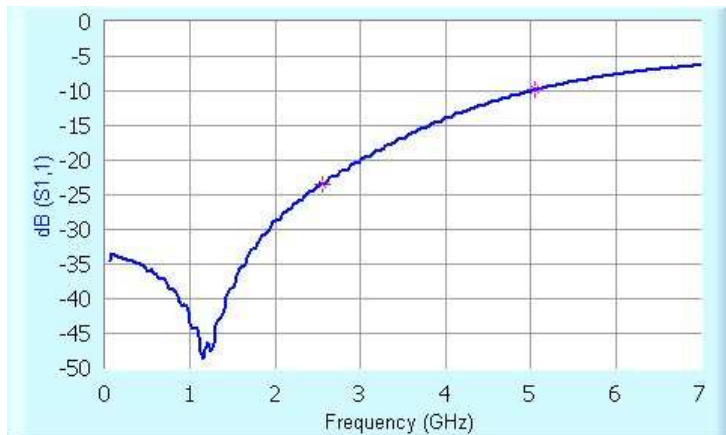

Measurement Fixture:

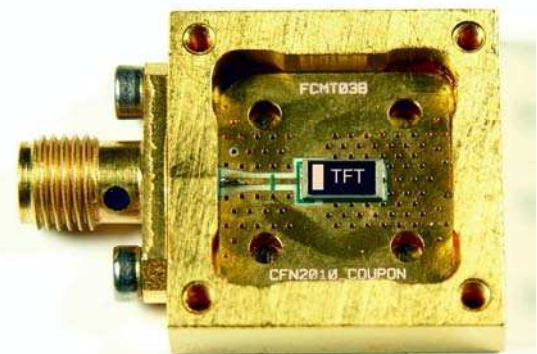

TFT Produced Coaxial Measurement Module (CMM) incorporating recommended land pattern

Power Derating Curve:

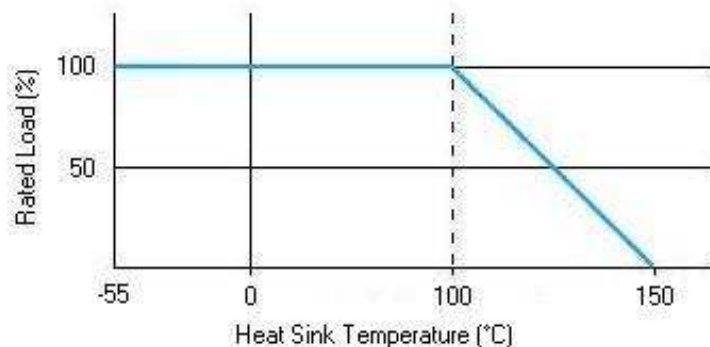

Recommended Land Pattern:

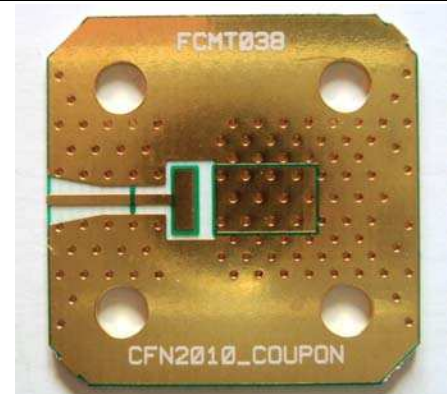

Material = Rogers 4250B, 10 mil thickness
Call factory for DXF output of land pattern

Environmental Performance Specifications:

Test	Reference	Conditions of Test	Requirement
Load Life ¹	MIL-PRF-55342, MIL-STD-202 Method 108A	100% Rated power (1,000 hours)	± 2.0% + 0.01Ω
Moisture Resistance	MIL-PRF-55342, MIL-STD-202 Method 106G	85°C / 85%RH, no load (1,000 hrs)	± 1.0% + 0.01Ω
Low Temperature Storage	MIL-STD-883 Method 1008.2 Condition B	-40°C (1,000 hrs)	± 0.5% + 0.01Ω
High Temperature Storage	MIL-STD-883 Method 1008.2 Condition B	+155°C (1,000 hrs)	± 0.5% + 0.01Ω
Air to Air Thermal Shock	MIL-PRF-55342, MIL-STD-202 Method 107G	-55°C / +155°C (25 cycles)	± 0.5% + 0.01Ω
Resistance to Soldering Heat	MIL-PRF-55342 MIL-STD-202 Method 210F	3 dips @ 260°C for 10 sec each	± 0.5% + 0.01Ω
Solderability	MIL-PRF-55342 MIL-STD-202 Method 208H	1 dip @ 260°C for 5 sec	Min 95% coverage of critical area

Note 1: Chip and board mounted to copper heat sink during test. Film temperature not to exceed 150°C.

Tape and Reel Packaging:

Packaging Specifications	General Guidelines & Recommendations
Packaging Requirements	<ul style="list-style-type: none"> All taping done in accordance with EIA 481 standards. Pieces taped with the marking up and showing through the cover tape (as shown in the drawing below). All orders under 100 pcs will be put on cut tape only with no leader or trailer.
Labeling Requirements	Labels will contain the TFT part number and quantity of pieces taped.

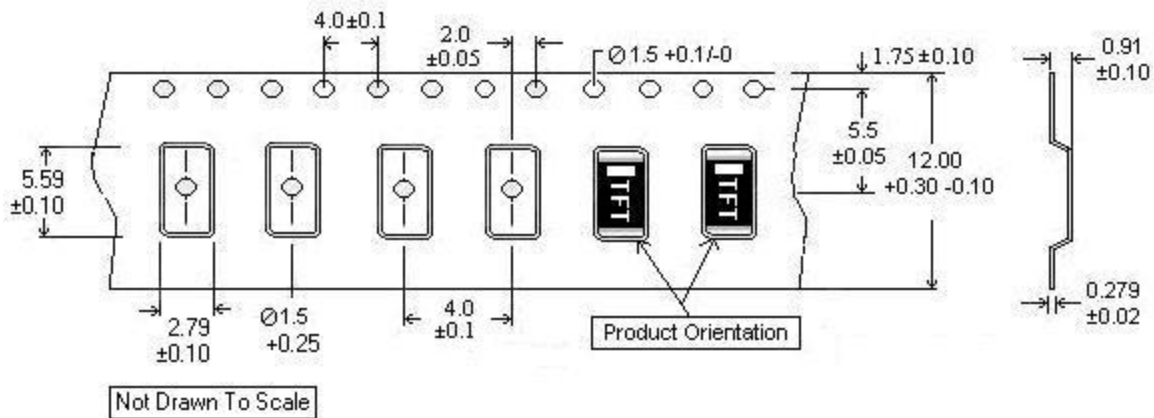

Note: All dimensions in mm