

Features

- Low On-Resistance: 7.0Ω typical.
- V_{CC} Range: 2.7V to 4.2V ±10%
- Switching Speed 20nS
- Break-Before-Make Switching
- Extended Industrial Temperature Range: -40°C to 85°C
- LoPro™ Packaging (Pb-free): 10-Lead Micro Package
- Bandwidth > 1GHz @ -3dB roll-off.
- Compatible with 1.8V systems.
- Power off protection.
- C_{IN} Capacitance 1.5pF. C_{ON} (D+ D-) Capacitance 3.7pF

Applications

- Hand Held Devices
- Cell Phones
- PDA's
- Notebooks
- LCD Monitors
- Set Top Box
- USB2.0 Applications

Pin Definitions

Pin No. PA2983	Name	Description
8	\overline{OE}	Switch Enable
4	GND	Ground
1,2,6,7	HSD1n, HSD2n.	Multiplexed DATA I/O
3,5	D+, D-	Common Port / USB DATA
9	V _{CC}	Positive Power Supply
10	SEL	Switch Select

Logic Function Table

\overline{OE}	SEL	Function
H	X	I/O's = Hi-Z
L	L	D+,D- = HSD1+, HSD1-
L	H	D+,D- = HSD2+,HSD2-.

Description

ProTek Analog's PA2983, PA2983L is a bidirectional two-port Hi-speed USB2.0 switch. Configured as a double-pole double throw (DPDT) switch, it is optimized for switching between two 480Mbps sources or a Hi-speed and Full-speed 12Mbps source.

The bandwidth of 1GHz allows passing of the 3rd Harmonic, resulting in minimal edge and phase distortion.

Superior channel to channel crosstalk minimizes interference.

Functional Block Diagram

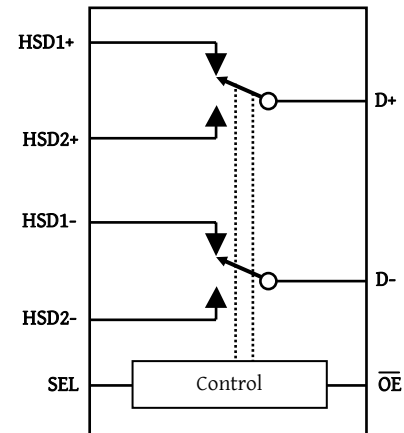

Pin Configuration (Top through View)

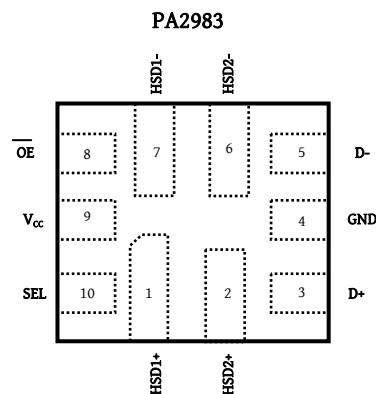

Temperature Range	Package	Part Number
-40 to 85 °C	10 Lead LoPro	PA2983-T7

Absolute Maximum Ratings⁽¹⁾

Supply Voltage.....	-0.5V to 4.6V
DC Input Voltage.....	-0.5V to $V_{CC} + 0.5V$
DC Output Current	$\pm 120mA$
Storage Temperature Range	-65°C to +150°C
Power Dissipation (P_D) @ +85°C.....	500mW

Notes:-

1. "Absolute Maximum Ratings" may cause permanent damage to the device. This is a stress only rating and operation of the device at these or any other conditions beyond those indicated in the operational sections of this specification is not implied.
2. The input and output negative voltage ratings may be exceeded if the input and output diode current ratings are observed.
3. Control input must be held HIGH or LOW; it must not float

Recommended operating Conditions

SYMBOL	PARAMETER	MIN	MAX	UNIT
V_{CC}	Supply Voltage	2.7	4.2	V
V_{CNTRL}	Control Input Voltage	0	V_{CC}	V
V_{SW}	Switch I/O Voltage	-0.5	4.5	V
T_A	Operating Temperature			°C

DC Electrical Characteristics

SYMBOL	PARAMETER	CONDITIONS	V_{CC} (V)	$T_A = 40^\circ C$ to $+85^\circ C$			UNITS
				MIN	TYP	MAX	
V_{IK}	Clamp Diode Voltage	$I_{IN} = 18mA$	3.0			-1.2	V
V_{IH}	Input Voltage High		3.0 to 3.6	1.3			V
			4.2	1.7			V
V_{IL}	Input Voltage Low		3.0 to 3.6			0.5	V
			4.2			0.7	V
I_{IN}	Control Input Leakage	$V_{SW} = 0$ to V_{CC}	4.2	-1		1	μA
I_{OZ}	Off State Leakage	$0 \leq Dn, HSD1n, HSD2n \leq 3.6V$	4.2	-2		2	μA
I_{OFF}	Power Off Leakage Current	$V_{SW} = 0V$ to $4.3V$, $V_{CC} = 0V$ See Figure 4.	0	-2		2	μA
R_{ON}	Switch On Resistance ⁽¹⁾	$V_{SW} = 0V$ to $4.3V$, $I_{ON} = -8mA$ See Figure 3.	3.0		7		Ω
ΔR_{ON}	Delta R_{ON} ⁽²⁾	$V_{SW} = 0.4V$, $I_{ON} = -8mA$	3.0		0.6		Ω
I_{CC}	Quiescent Supply Current	$V_{CNTRL} = 0$ or V_{CC} , $I_{OUT} = 0$	4.2			1.0	μA
I_{CCT}	Increase in I_{CC} per Control Voltage and V_{CC}	$V_{CNTRL} = 2.6V$, $V_{CC} = 4.3V$	4.2			10.0	μA
		$V_{CNTRL} = 1.8V$, $V_{CC} = 4.3V$	4.2			15.0	μA

Notes:

1. Measured by voltage drop between HSDn and Dn pins at the indicated current through the switch.
2. Guaranteed by characterization

AC Electrical Characteristics

SYMBOL	PARAMETER	CONDITIONS	V _{CC} (V)	T _A = 40 °C to +85 °C			UNITS
				MIN	TYP	MAX	
t _{ON}	Turn-On Time S, \overline{OE} to Output	R _L = 50Ω, C _L = 5pF V _{SW} = 0.8V See Figure 5, Figure 6.	3.0 to 3.6		13	30	nS
t _{OFF}	Turn-Off Time S, \overline{OE} to Output	R _L = 50Ω, C _L = 5pF V _{SW} = 0.8V See Figure 5, Figure 6	3.0 to 3.6		12	25	nS
t _{PD}	Propagation Delay ⁽³⁾	R _L = 50Ω, C _L = 5pF	3.3		0.25		nS
t _{BBM}	Break-Before-Make	R _L = 50Ω, C _L = 5pF V _{SW} = 0.8V See Figure 7.	3.0 to 3.6	2.0		6.0	nS
O _{IRR}	Off Isolation	R _L = 50Ω, f = 240MHz See Figure 9.	3.0 to 3.6		-30		dB
X _{TALK}	Non-Adjacent Channel Crosstalk	R _L = 50Ω, f = 240MHz See Figure 10.	3.0 to 3.6		-45		dB
BW	-3dB Bandwidth	R _L = 50Ω, C _L = 0pF See Figure 8.	3.0 to 3.6		1000		MHz
		R _L = 50Ω, C _L = 5pF See Figure 8.	3.0 to 3.6		855		MHz

Notes:

3. Guaranteed by characterization

USB High Speed Related AC Electrical Characteristics

SYMBOL	PARAMETER	CONDITIONS	V _{CC} (V)	T _A = 40 °C to +85 °C			UNITS
				MIN	TYP	MAX	
t _{SK(P)}	Skew of Opposite Transitions of the same Output	R _L = 50Ω, C _L = 5pF.	3.0 to 3.6		20		pS
t _J	Total Jitter ⁽⁴⁾	R _L = 50Ω, C _L = 5pF t _R =t _F =500pS (10 to 90%) at 480Mbps (PRBS=2 ¹⁵ -1)	3.0 to 3.6		200		pS

Notes:

4. Guaranteed by characterization

Capacitance

SYMBOL	PARAMETER	CONDITIONS	T _A = 40 °C to +85 °C			UNITS
			MIN	TYP	MAX	
CIN	Control Pin Input Capacitance	V _{CC} = 0V		1.5		pF
CON	D+ / D- On Capacitance	V _{CC} = 3.3V, \overline{OE} = 0V, f=240MHz See Figure 12		3.7		
COFF	D1n, D2n Off Capacitance	V _{CC} = 3.3V, \overline{OE} = 3.3V See Figure 11		2.0		

Test Diagrams.

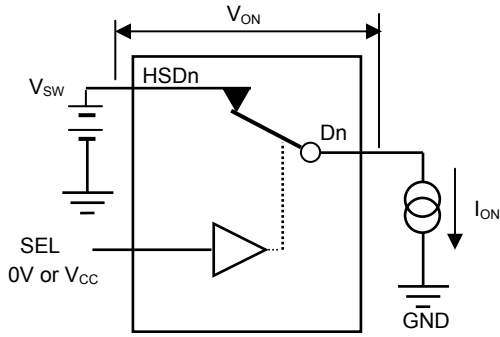

Fig.3 On Resistance

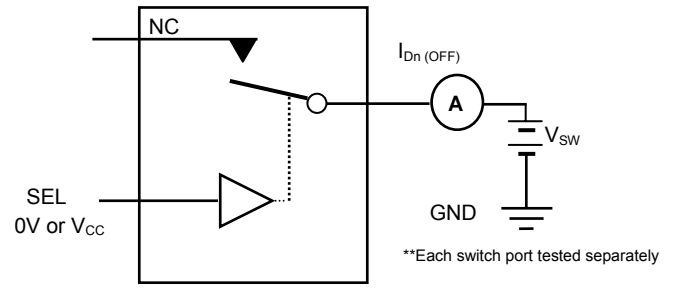

Fig.4 Off Leakage.

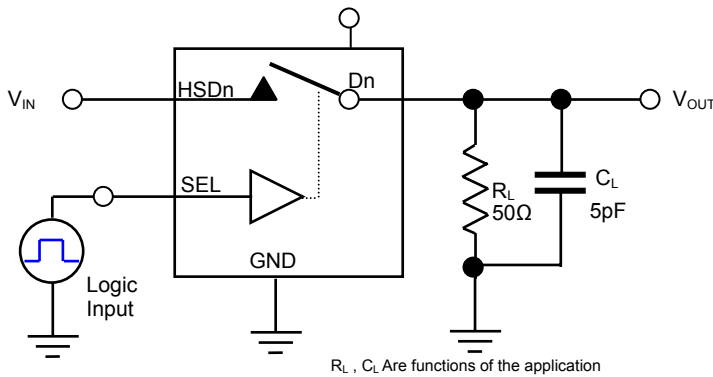

Fig.5 AC Test Circuit

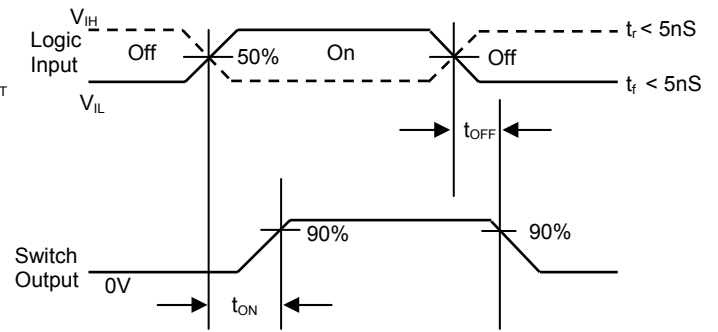

Fig.6 Turn-On / Turn-Off Waveforms

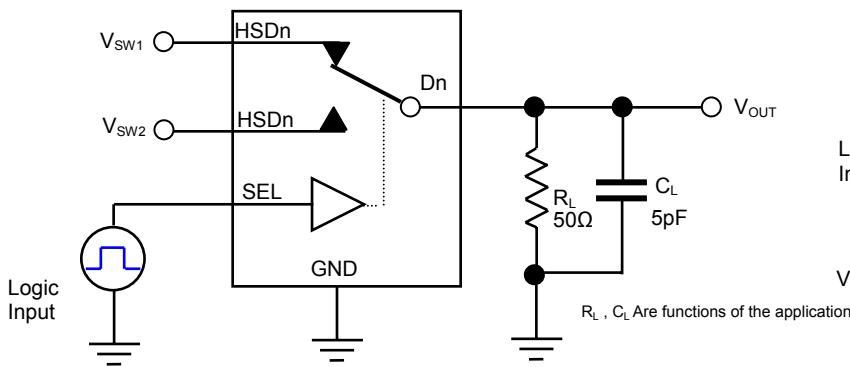
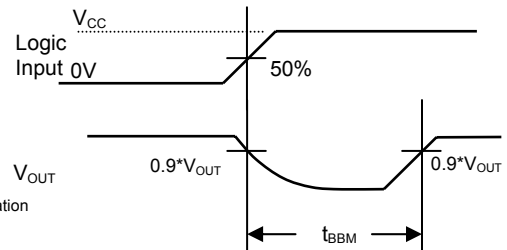
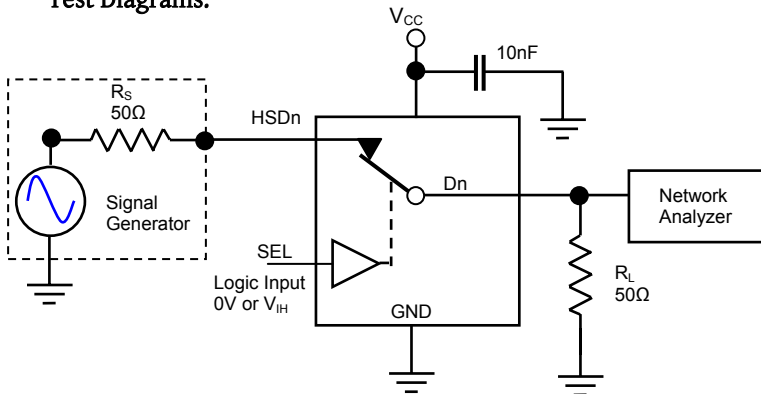

Fig.7 Break-Before-Make interval Timing



Test Diagrams.



RL, CL Are functions of the application

Fig.8 Bandwidth

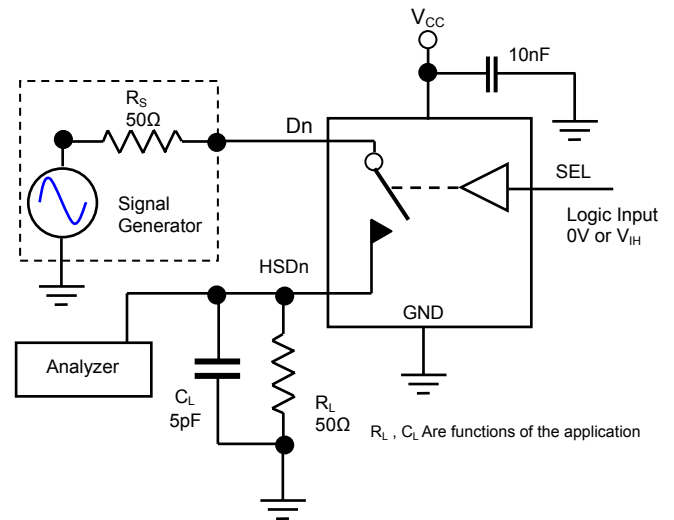

RL, CL Are functions of the application

Fig.9 Channel Off Isolation

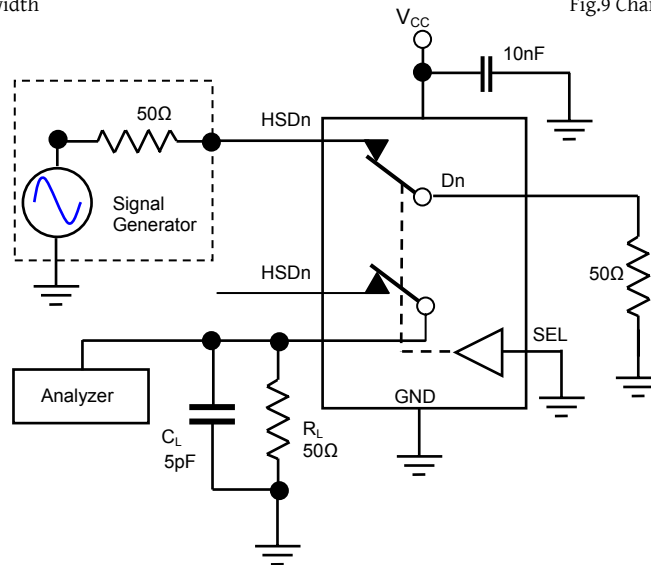

Fig.10 Non-Adjacent Channel-to-Channel Crosstalk

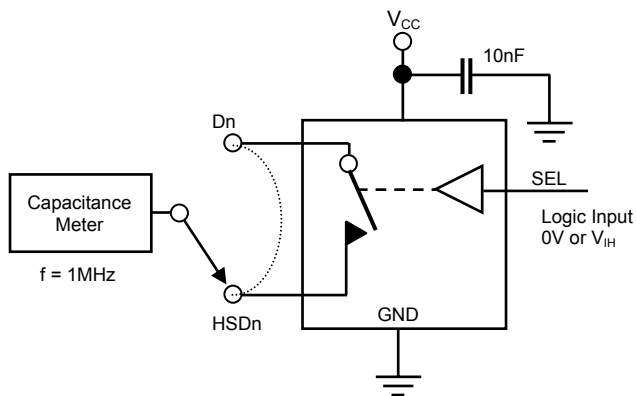

Fig.11 Channel Off Capacitance.

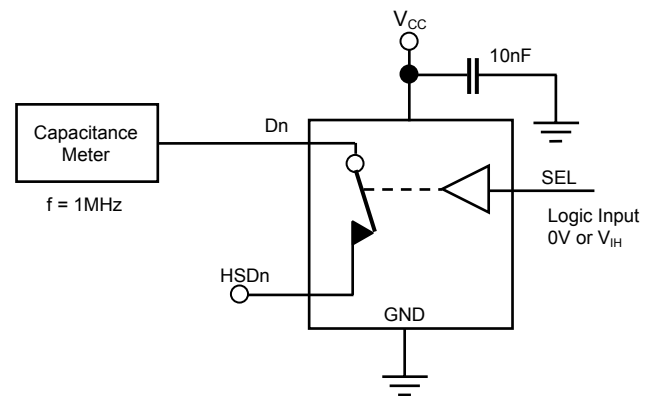
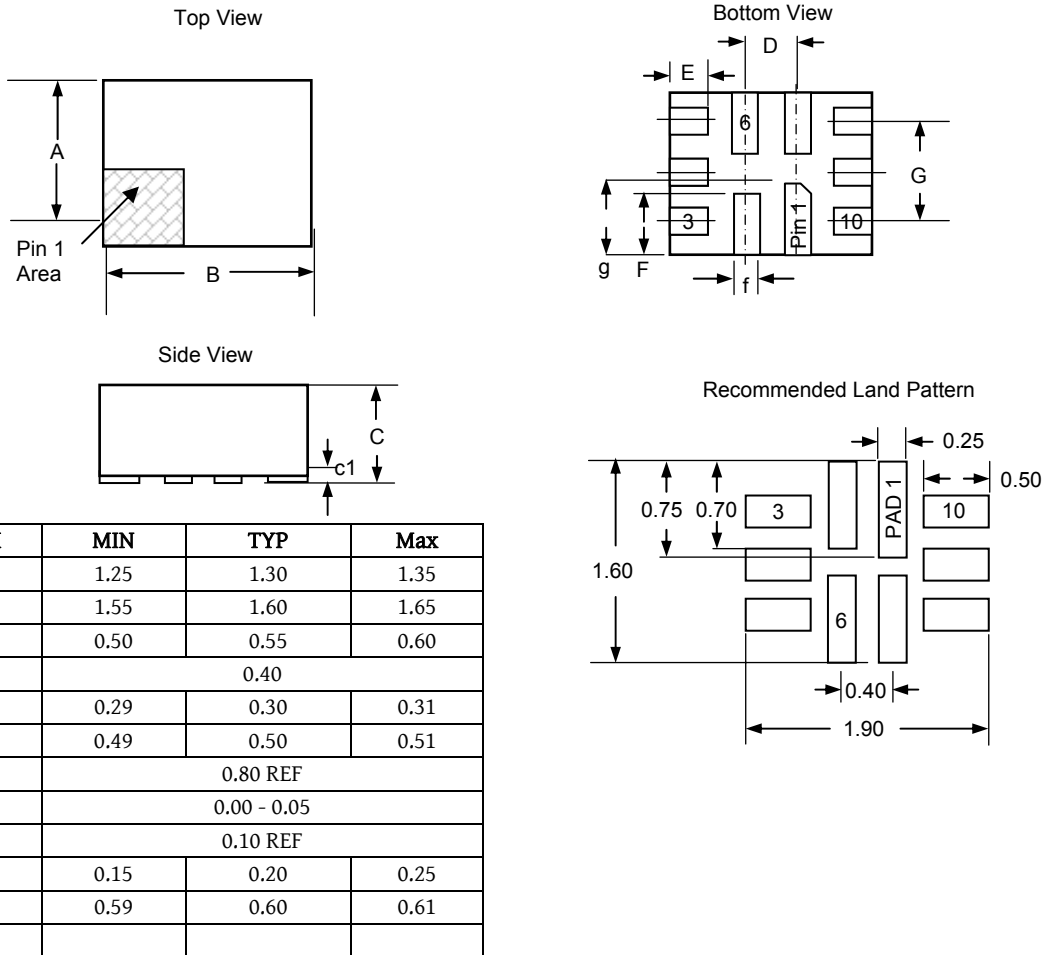

Fig.12 Channel On Capacitance.

Package Layout and Dimensions

Note: Dimensions in millimeters

Tape and Reel Specifications

Reel Dia	A0	B0	K0	D	E	F	W	P0	P2	P	t-max
178 (7")	1.47±0.05	1.73±0.05	0.65±0.05	1.50±0.10	1.75±0.10	3.50±0.05	12.00±0.30	4.00±0.10	2.00±0.05	4.00±0.10	0.25

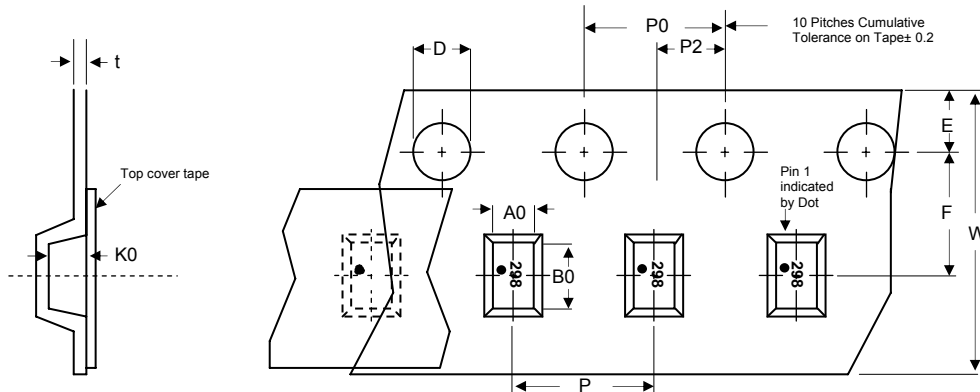

561 E. Elliot Road #175 Chandler, AZ 85225 Tel: (480) 539-2900. Fax: (480) 632-1715

www.protekanalog.com