

ISSUE NUMBER

ORIGINAL

1

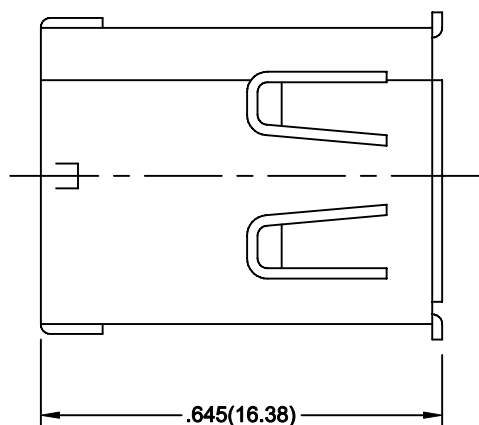

MATERIALS AND FINISH:

HOUSING: HIGH TEMPERATURE THERMO-PLASTIC, UL94-0, BLACK.

SHELL: COPPER ALLOY OR STEEL, NICKEL PLATED.

CONTACTS: COPPER ALLOY, 30 MICRINCHES OF GOLD PLATED ON MATING AREA
TIN ON SOLDER TAILS OVER NICKEL.

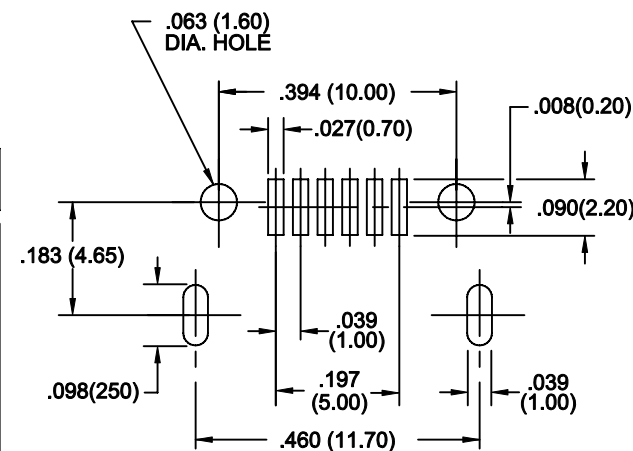
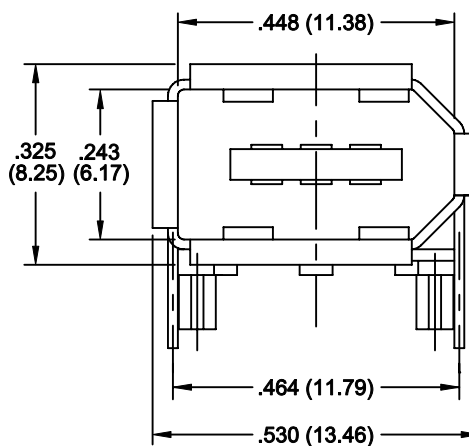
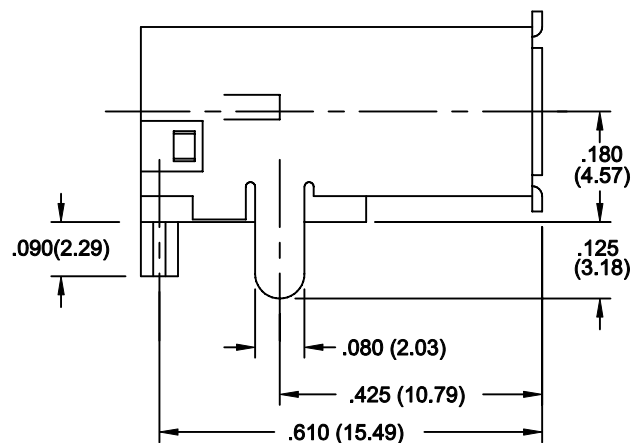

PC BOARD MOUNTING DIMENSIONS

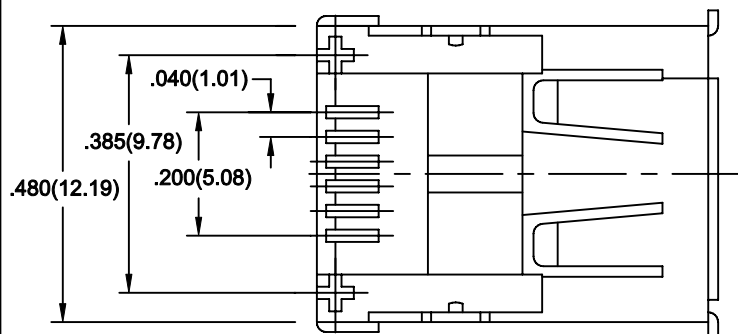

THIS SERIES FULLY CONFORMS TO THE EUROPEAN UNION DIRECTIVES 2002/95/EC AND 2002/96/EC FOR RoHS COMPLIANCY.

**IEEE 1394 CONNECTOR
SURFACE MOUNT**

ACAD REF. 693-006-699-003

DRAWN. F.BRIONES

DATE. NOV. 04/03

PART NUMBER.

693-006-699-003

DRAWING NUMBER.

693-006-699-003

ISSUE

2



EDAC INC.
TORONTO, ONTARIO
CANADA

YOUR CONNECTION TO QUALITY & SERVICE

THESE DRAWINGS AND SPECIFICATIONS ARE THE PROPERTY OF EDAC INC. AND SHALL NOT BE REPRODUCED OR COPIED OR USED AS THE BASIS FOR THE MANUFACTURE OR SALE OF APPARATUS WITHOUT WRITTEN PERMISSION.