

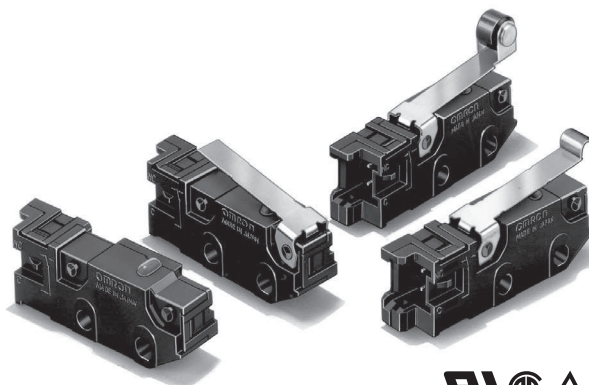

# Subminiature Snap Action Switch D3M

## Saves Wiring Effort, Production Steps, and Time

- Easy wiring ensured through the Quick-Connect Terminals
- External actuator mounts in either of two directions
- Horizontal layout of terminals saves mounting space
- Same mounting pitch and internal mechanism as the OMRON SS Subminiature Snap Action Switch
- RoHS Compliant

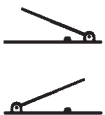
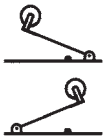
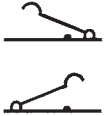

## Ordering Information

Actuator	Actuator mounting position	Contact type	Model
Pin plunger 	—	SPST-NC	D3M-01
		SPST-NO	D3M-01-3
Hinge lever 	High ratio operating position ("K" actuator position)	SPST-NC	D3M-01K1
		SPST-NO	D3M-01K1-3
	Standard operating position ("L" actuator position)	SPST-NC	D3M-01L1
		SPST-NO	D3M-01L1-3
Hinge roller lever 	High ratio operating position ("K" actuator position)	SPST-NC	D3M-01K2
		SPST-NO	D3M-01K2-3
	Standard operating position ("L" actuator position)	SPST-NC	D3M-01L2
		SPST-NO	D3M-01L2-3
Simulated roller lever 	High ratio operating position ("K" actuator position)	SPST-NC	D3M-01K3
		SPST-NO	D3M-01K3-3
	Standard operating position ("L" actuator position)	SPST-NC	D3M-01L3
		SPST-NO	D3M-01L3-3

## Model Number Legend

D3M-01□□□  
1 2 3

### 1. Actuator Mounting Position

None: No actuator

K: Pushbutton close to actuator fulcrum

L: Pushbutton far from actuator fulcrum

"K" Actuator Position

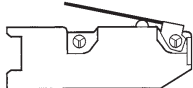

"L" Actuator Position

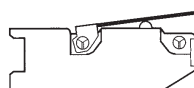

### 2. Actuator

None: Pin plunger

1: Hinge lever

2: Hinge roller lever

3: Simulated roller lever

### 3. Contact Form

None: SPST-NC (with red pushbutton)

-3: SPST-NO (with black pushbutton)

# Specifications

## ■ Characteristics

Electrical Rating (See note 4)	0.1 A at 30 VDC, resistive
Operating speed	0.1 mm/s to 1 m/s (pin plunger models)
Operating frequency	Mechanical: 400 operations/minute max. Electrical: 30 operations/minute max.
Insulation resistance	100 MΩ min. at 500 VDC
Contact resistance	100 mΩ max. including connector and 50-mm AWG28 lead wire resistance
Dielectric strength (See note 2)	1,000 VAC at 50/60 Hz for 1 minute between terminals of the same polarity 1,500 VAC at 50/60 Hz for 1 minute between charged metal part and ground 1,500 VAC at 50/60 Hz for 1 minute between non-charged metal part and each terminal
Vibration resistance (See note 3)	Malfunction: 10 to 55 Hz, 1.5-mm double amplitude
Shock resistance (See note 3)	Destruction: 1,000 m/s <sup>2</sup> (approx. 100G) max. Malfunction: 300 m/s <sup>2</sup> (approx. 30G) max.
Degree of protection	IEC IP40
Degree of protection against electric shock	Class I
Proof tracking index (PTI)	175
Ambient operating temperature	-25°C to 85°C (at 60% RH max) with no icing
Ambient operating humidity	85% max. (for 5°C to 35°C)
Life expectancy	Mechanical: 500,000 operations at 60 operations/minute Electrical: 200,000 operations at 30 operations/minute
Weight	Approx. 2 g (pin plunger model)

- Note:**
1. Data shown are of initial value.
  2. The dielectric strength shown is measured using a separator between the switch and metal mounting plate.
  3. For the pin plunger models, the above values apply for use at the free position and total travel position. For the lever models, they apply at the total travel position. Contact opening or closing time is within 1 ms.
  4. The electrical ratings apply under the following test conditions: Ambient Temperature = 20±2°C, Ambient Humidity = 65±5%, Operating frequency = 30 operations/min.

## ■ Approved Standards

### UL Recognized/CSA Certified

Rated voltage	D3M
30 VDC	0.1 A

### EN61058-1 (TÜV Rheinland approval)

Rated voltage	D3M
30 VDC	0.1 A

Testing conditions: 1E5 (100,000 operations), T85 (0°C to 85°C)

## ■ Contact Specifications

Item	Specification
Specification	Crossbar
Material	Gold alloy
Contact gap	0.5 mm
Inrush current	1 A max.
Minimum applicable load (see note)	1 mA at 5 VDC

**Note:** Minimum applicable loads are indicated by N standard reference values. This value represents the failure rate at a 60% ( $\lambda_{60}$ ) reliability level (JIS C5003).  
The equation  $\lambda_{60}=0.5 \times 10^{-6}$  / operations indicates that a failure rate of 1/2,000,000 operations can be expected at a reliability level of 60%

# Engineering Data

## ■ Mounting Holes

All switches may be panel mounted using M2.3 mounting screws with plane washers or spring washers to securely mount the switch. Tighten the screws to a torque of 0.23 to 0.26 N·m.

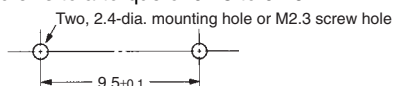

## ■ Contact Form



# Dimensions

**Note:** 1. Unless otherwise specified, all units are in millimeters and a tolerance of  $\pm 0.4$  mm applies to all dimensions  
 2. The operating characteristics are for operation in the A direction(↓)

## Pin Plunger Models

D3M-01  
 D3M-01-3

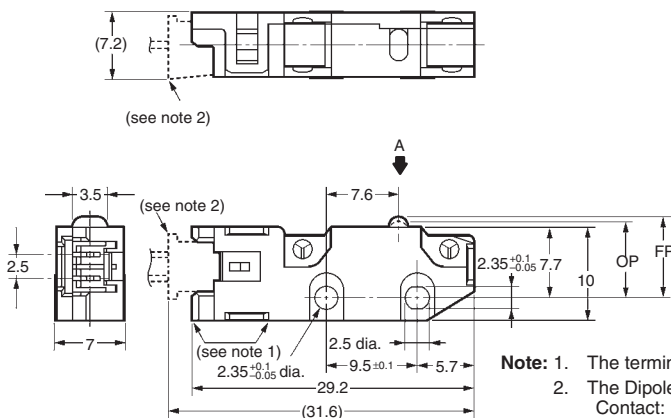
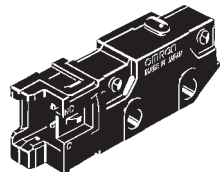

<b>OF max</b>	153 gf
<b>RF min.</b>	25 gf
<b>PT max.</b>	0.6 mm
<b>OT min.</b>	0.4 mm
<b>MD max.</b>	0.1 mm
<b>OP</b>	8.4 $\pm$ 0.3 mm

## Hinge Lever Models (K)

D3M-01K1  
 D3M-01K1-3

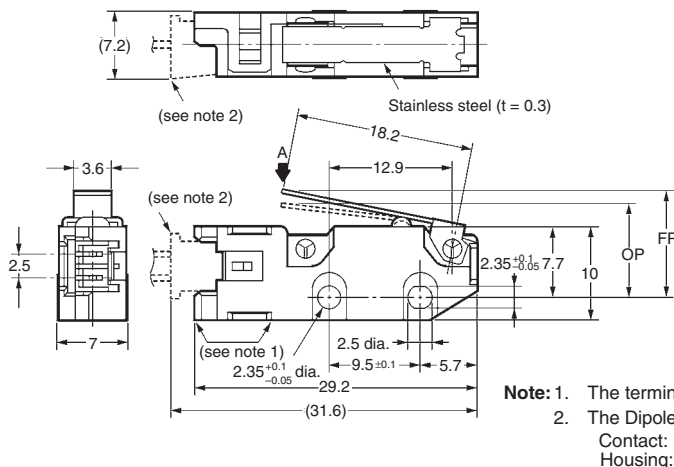
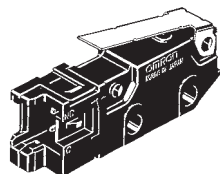

<b>OF max</b>	51 gf
<b>RF min.</b>	6 gf
<b>OT min.</b>	1.2 mm
<b>MD max.</b>	0.8 mm
<b>FP max.</b>	14.0 mm
<b>OP</b>	10.0 $\pm$ 0.8 mm

## Hinge Lever Models (L)

D3M-01L1  
 D3M-01L1-3

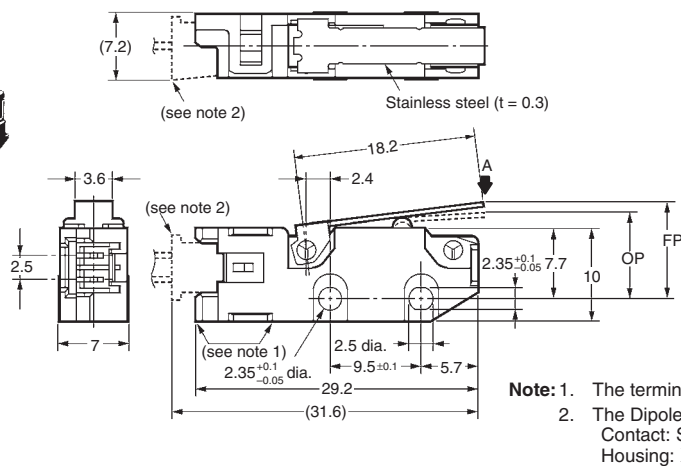
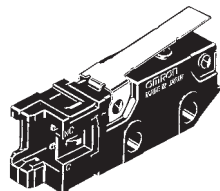

<b>OF max</b>	102 gf
<b>RF min.</b>	10 gf
<b>OT min.</b>	0.7 mm
<b>MD max.</b>	0.6 mm
<b>FP max.</b>	11.5 mm
<b>OP</b>	9.2 $\pm$ 0.6 mm

**Note: 1.** Unless otherwise specified, all units are in millimeters and a tolerance of  $\pm 0.4$  mm applies to all dimensions  
**2.** The operating characteristics are for operation in the A direction(▼)

**Hinge Roller Lever Models (K)**

D3M-01K2  
D3M-01K2-3

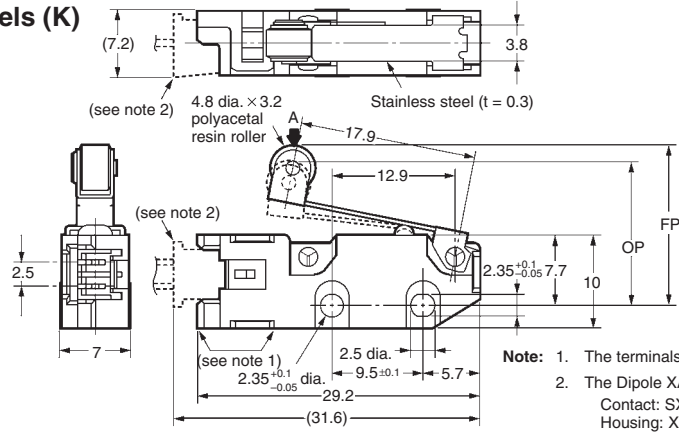
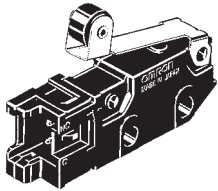

<b>OF max</b>	51 gf
<b>RF min.</b>	6 gf
<b>OT min.</b>	1.2 mm
<b>MD max.</b>	0.8 mm
<b>FP max.</b>	19.7 mm
<b>OP</b>	15.7 $\pm$ 0.8 mm

**Note: 1.** The terminals connect to JST's Dipole XA Connector.  
**2.** The Dipole XA Connector consists of the following components.  
Contact: SXA-001T-P0.6  
Housing: XAP-02V-1

**Hinge Roller Lever Models (L)**

D3M-01L2  
D3M-01L2-3

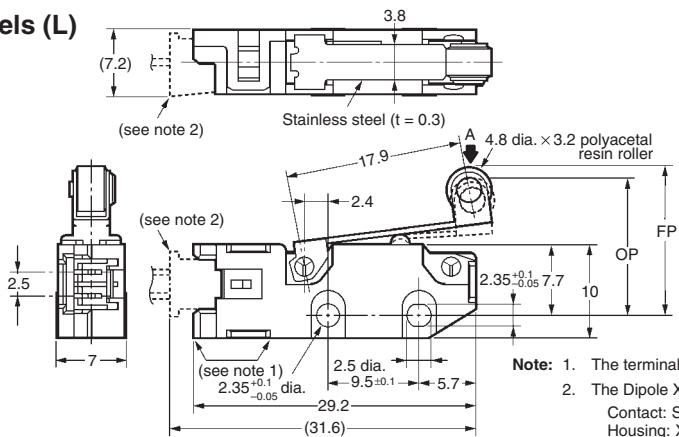
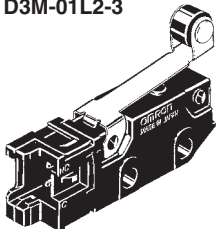

<b>OF max</b>	102 gf
<b>RF min.</b>	10 gf
<b>OT min.</b>	0.7 mm
<b>MD max.</b>	0.6 mm
<b>FP max.</b>	17.2 mm
<b>OP</b>	14.9 $\pm$ 0.6 mm

**Note: 1.** The terminals connect to JST's Dipole XA Connector.  
**2.** The Dipole XA Connector consists of the following components.  
Contact: SXA-001T-P0.6  
Housing: XAP-02V-1

**Simulated Roller Lever Models (K)**

D3M-01K3  
D3M-01K3-3

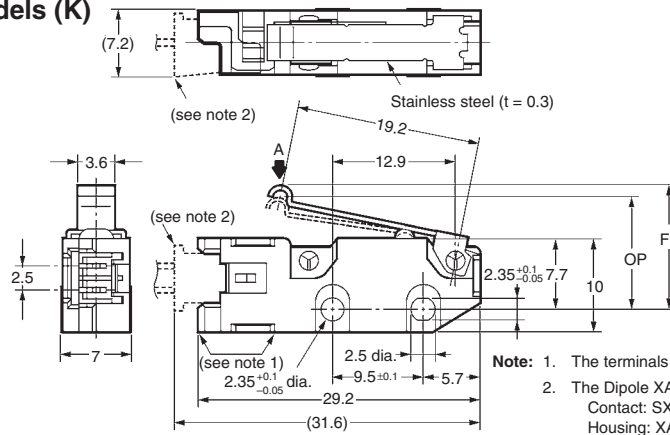
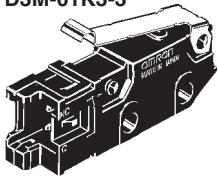

<b>OF max</b>	51 gf
<b>RF min.</b>	6 gf
<b>OT min.</b>	1.2 mm
<b>MD max.</b>	0.8 mm
<b>FP max.</b>	16.2 mm
<b>OP</b>	12.2 $\pm$ 0.8 mm

**Note: 1.** The terminals connect to JST's Dipole XA Connector.  
**2.** The Dipole XA Connector consists of the following components.  
Contact: SXA-001T-P0.6  
Housing: XAP-02V-1

**Simulated Roller Lever Models (L)**

D3M-01L3  
D3M-01L3-3

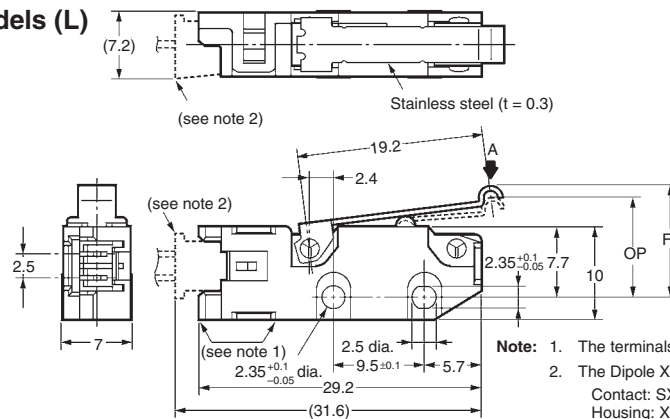
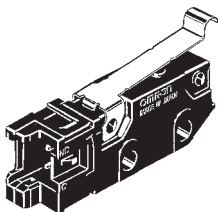

<b>OF max</b>	102 gf
<b>RF min.</b>	10 gf
<b>OT min.</b>	0.7 mm
<b>MD max.</b>	0.6 mm
<b>FP max.</b>	13.6 mm
<b>OP</b>	11.3 $\pm$ 0.6 mm

**Note: 1.** The terminals connect to JST's Dipole XA Connector.  
**2.** The Dipole XA Connector consists of the following components.  
Contact: SXA-001T-P0.6  
Housing: XAP-02V-1

# Precautions

Be sure to read the precautions and information common to all Snap Action and Detection Switches, contained in the Technical User's Guide, "Snap Action Switches, Technical Information" for correct use.

## ■ Correct Use

### Mounting

Make sure that the surface to which the D3M is mounted is flat. If the surface is not flat, the housing may distort, and the D3M may malfunction, or the housing may crack.

### Operating Stroke

Make sure that the dog is separated from the actuator when the actuator is in the free position and that the actuator is pressed appropriately when the D3M is actuated. The actuator must not be pressed excessively to reach the maximum overtravel position, or the D3M may be damaged.

Make sure the actuator is pressed in the direction where the D3M is actuated.

### Using Microloads

Using a model for ordinary loads to switch microloads may result in faulty operation. Instead, use the models that are designed for microloads and that operate in the following range;

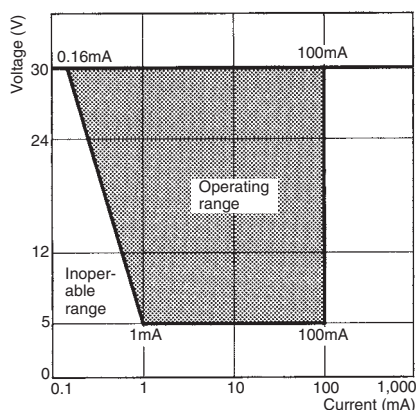

However, even when using microload models within the operating range shown above, if inrush current or inductive voltage spikes occur when the contact is opened or closed, then contact wear may increase and so decrease the service life. Therefore, insert a contact protection circuit where necessary.

### Wiring

The terminals connect to JST's Dipole XA Connector.

The Dipole XA Connector consists of the following components.

Contact: SAX-001T-P0.6

Housing: XAP-02V-1

OMRON does not sell the Dipole XA Connector.

Contact J.S.T. Manufacturing Co. for these connectors.

## ■ Cautions

### Handling

To avoid an electric shock or a fire, be sure to turn OFF the D3M before mounting, removing, wiring, or servicing.

### ⚠ CAUTION

The voltage and current applied to the D3M must be within the rated ranges when it is turned ON, turned OFF, and in operation, or the service life of the D3M may be shortened. Also note that if inappropriate voltage and current are applied, the D3M may radiate heat and burn.

All sales are subject to Omron Electronic Components LLC standard terms and conditions of sale, which can be found at [http://www.components.omron.com/components/web/webfiles.nsf/sales\\_terms.html](http://www.components.omron.com/components/web/webfiles.nsf/sales_terms.html)

**ALL DIMENSIONS SHOWN ARE IN MILLIMETERS.**

To convert millimeters into inches, multiply by 0.03937. To convert grams into ounces, multiply by 0.03527.

---

**OMRON**<sup>®</sup>

**OMRON ELECTRONIC  
COMPONENTS LLC**

55 E. Commerce Drive, Suite B  
Schaumburg, IL 60173

**847-882-2288**

**OMRON ON-LINE**

Global - <http://www.omron.com>

USA - <http://www.components.omron.com>