

MOS FET Relays

G3VM-21BR/ER

Higher Power, 4A switching with a 20V load, DIP package. Low 20 mΩ ON Resistance.

- Continuous load current of 4A (Connection C: 8A)
- Switches minute analog signals
- Dielectric strength of 2,500 Vrms between I/O
- RoHS Compliant

Application Examples

- Communication equipment and Measurement devices
- Security systems and Power circuits
- Factory Automation equipment

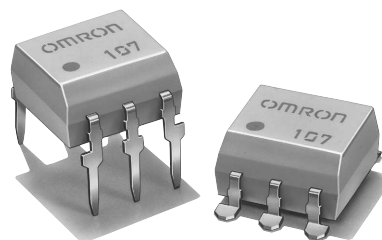

NEW

Note: The actual product is marked differently from the image shown here.

List of Models

Package Type	Contact form	Terminals	Load voltage (peak value)	Model	Number per stick	Number per tape
DIP6	SPST-NO	PCB terminals	20 V	G3VM-21BR	50	---
		Surface-mounting terminals		G3VM-21ER		
				G3VM-21ER(TR)	---	1,500

Note: The AC peak and DC value are given for the load voltage.

Dimensions

Note: All units are in millimeters unless otherwise indicated.

G3VM-21BR

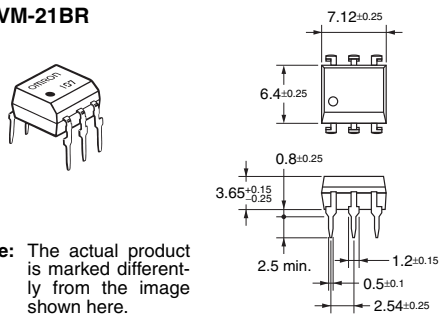

G3VM-21ER

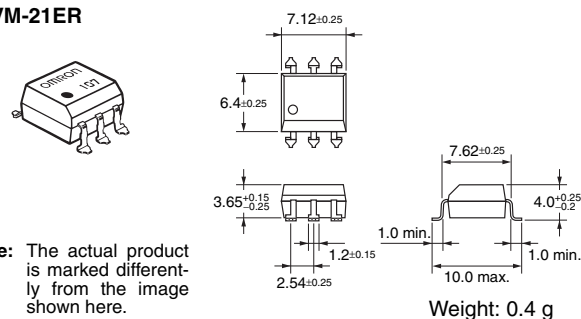

Terminal Arrangement/Internal Connections (Top View)

G3VM-21BR

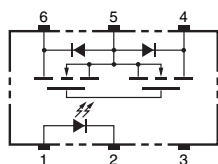

G3VM-21ER

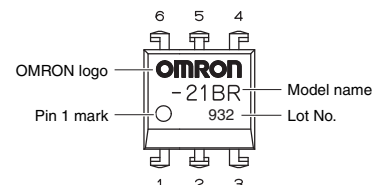
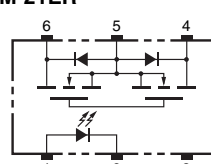

Note: The actual product is marked differently from the image shown here.

PCB Dimensions (Bottom View)

G3VM-21BR

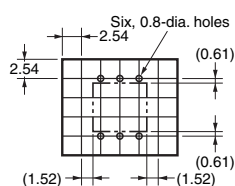

Actual Mounting Pad Dimensions (Recommended Value, Top View)

G3VM-21ER

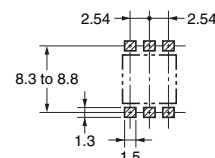

■ Absolute Maximum Ratings (Ta = 25°C)

Item		Symbol	Rating	Unit	Measurement Conditions	
Input	LED forward current	I_F	30	mA		
	Repetitive peak LED forward current	I_{FP}	1	A	100 μ s pulses, 100 pps	
	LED forward current reduction rate	$\Delta I_F/^\circ\text{C}$	-0.3	mA/°C	$T_a \geq 25^\circ\text{C}$	
	LED reverse voltage	V_R	5	V		
	Connection temperature	T_J	125	°C		
Output	Load voltage (AC peak/DC)	V_{OFF}	20	V		
	Continuous load current	Connection A	I_O	4	A	Connection A: AC peak/DC Connection B and C: DC
		Connection B		4		
		Connection C		8		
	ON current reduction rate	Connection A	$\Delta I_{IO}/^\circ\text{C}$	-40	mA/°C	$T_a \geq 25^\circ\text{C}$
		Connection B		-40		
		Connection C		-80		
Pulse on current	I_{OP}	12	A		t=100 ms, Duty = 1/10	
Connection temperature	T_J	125	°C			
Dielectric strength between input and output (See note 1.)		V_{I-O}	2,500	V_{rms}	AC for 1 min	
Operating temperature		T_a	-40 to +85	°C	With no icing or condensation	
Storage temperature		T_{stg}	-55 to +125	°C	With no icing or condensation	
Soldering temperature (10 s)		---	260	°C	10 s	

Note: 1. The dielectric strength between the input and output was checked by applying voltage between all pins as a group on the LED side and all pins as a group on the light-receiving side.

Connection Diagram

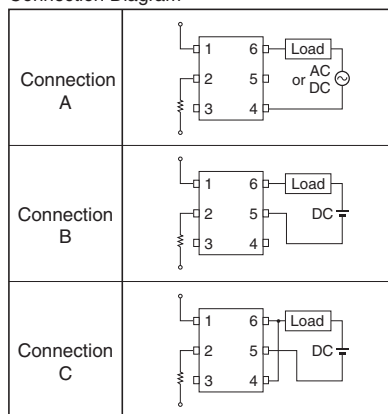

■ Electrical Characteristics (Ta = 25°C)

Item		Symbol	Minimum	Typical	Maximum	Unit	Measurement conditions	
Input	LED forward voltage	V_F	1.18	1.33	1.48	V	$I_F = 10 \text{ mA}$	
	Reverse current	I_R	---	---	10	μA	$V_R = 5 \text{ V}$	
	Capacity between terminals	C_T	---	70	---	pF	$V = 0, f = 1 \text{ MHz}$	
	Trigger LED forward current	I_{FT}	---	0.5	3	mA	$I_O = 1 \text{ A}$	
Output	Maximum resistance with output ON	Connection A	R_{ON}	---	20	50	$\text{m}\Omega$	$I_F = 5 \text{ mA}, I_O = 2 \text{ A}, t < 1 \text{ s}$
		Connection B		---	10	---	$\text{m}\Omega$	$I_F = 5 \text{ mA}, I_O = 2 \text{ A}, t < 1 \text{ s}$
		Connection C		---	5	---	$\text{m}\Omega$	$I_F = 5 \text{ mA}, I_O = 4 \text{ A}, t < 1 \text{ s}$
	Current leakage when the relay is open	I_{LEAK}	---	---	1.0	μA	$V_{OFF} = 20 \text{ V}$	
Capacity between terminals		C_{OFF}	---	1,000	---	pF	$V = 0, f = 1 \text{ MHz}$	
Capacity between I/O terminals		C_{I-O}	---	0.8	---	pF	$f = 1 \text{ MHz}, V_s = 0 \text{ V}$	
Insulation resistance between I/O terminals		R_{I-O}	1,000	---	---	$\text{M}\Omega$	$V_{I-O} = 500 \text{ VDC}, R_{oh} \leq 60\%$	
Turn-ON time		t_{ON}	---	2.5	5.0	ms	$I_F = 5 \text{ mA}, R_L = 200 \Omega, V_{DD} = 20 \text{ V}$ (See note 2.)	
Turn-OFF time		t_{OFF}	---	0.1	1.0	ms		

Note: 2. Turn-ON and Turn-OFF Times

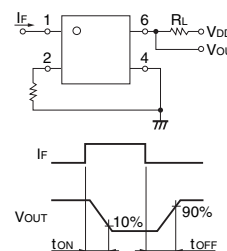

■ Recommended Operating Conditions

Use the G3VM under the following conditions so that the Relay will operate properly.

Item	Symbol	Minimum	Typical	Maximum	Unit
Load voltage (AC peak/DC)	V_{DD}	---	---	16	V
Operating LED forward current	I_F	5	10	25	mA
Continuous load current (AC peak/DC)	I_O	---	---	4	A
Operating temperature	T_a	-20	---	65	°C

■ Engineering Data

LED forward current vs. Ambient temperature

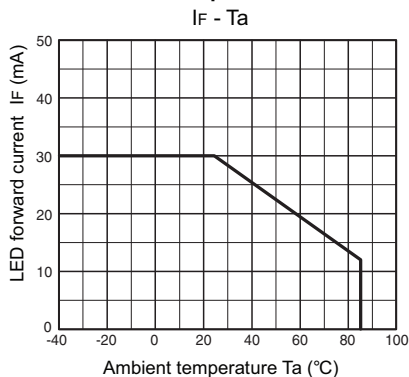

Continuous load current vs. Ambient temperature

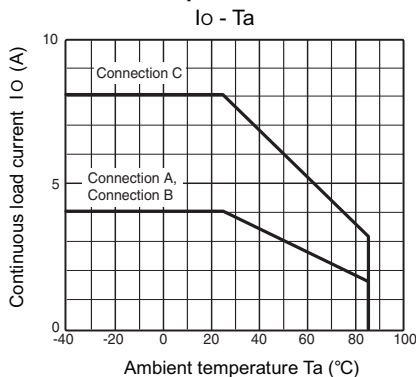

LED forward current vs. LED forward voltage

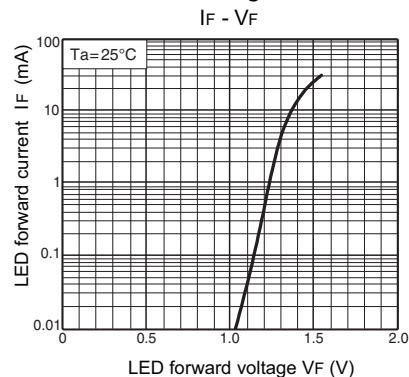

Continuous load current vs. On-state voltage

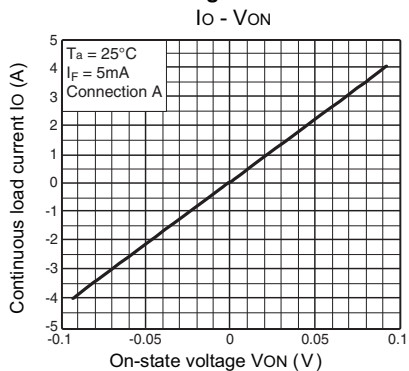

On-state resistance vs. Ambient temperature

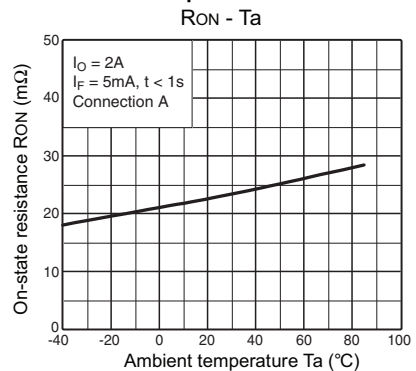

Trigger LED forward current vs. Ambient temperature

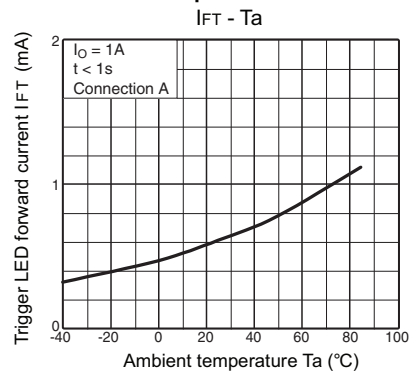

Turn ON, Turn OFF time vs. LED forward current

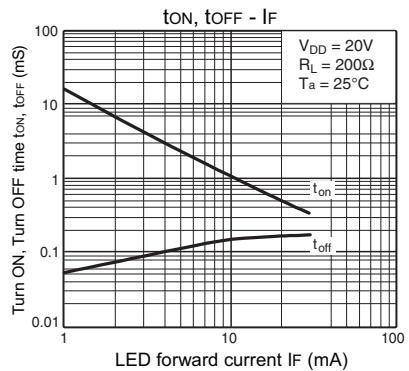

Turn ON, Turn OFF time vs. Ambient temperature

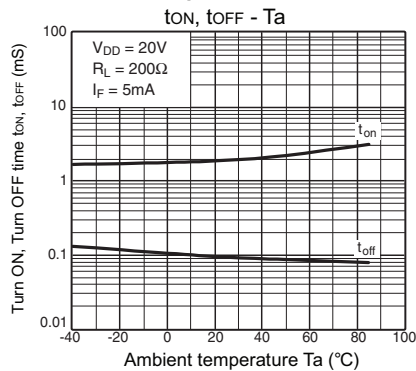

Current leakage vs. Ambient temperature

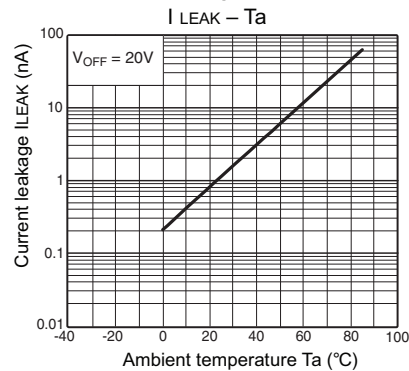

Precautions

Be sure to read the precautions and information common to all G3VM MOS FET relays, contained in the Technical User's Guide, "MOSFET Relays, Technical Information" for correct use.

All sales are subject to Omron Electronic Components LLC standard terms and conditions of sale, which can be found at http://www.components.omron.com/components/web/webfiles.nsf/sales_terms.html

ALL DIMENSIONS SHOWN ARE IN MILLIMETERS.
To convert millimeters into inches, multiply by 0.03937. To convert grams into ounces, multiply by 0.03527.

OMRON[®]

**OMRON ELECTRONIC
COMPONENTS LLC**

55 E. Commerce Drive, Suite B
Schaumburg, IL 60173

847-882-2288

OMRON ON-LINE

Global - <http://www.omron.com>

USA - <http://www.components.omron.com>