

### Peripheral-type, Compact, Manually Operated Card Reader

- Connects to the PC RS-232C port just like any other peripheral
- Sits conveniently next to the PC keyboard
- Easy-to-operate protocol
- Wide range of configurations available
- No external power supply required



### Ordering Information

Magnetic tracks supported (R, R/W)											
1	2	3	Center	JISII	IC contact	Interface	Communication (See Note 1,2,3)	Cover	Cable	Color	Part Number
R	R	R	—	—	No	RS 232C	Unidirectional	Yes	Yes	Ivory	<b>3S4YR-HNF1</b>
R	R	R	—	—	No	RS 232C	Bidirectional	Yes	Yes	Ivory	<b>3S4YR-HNF1-002</b>
—	R	—	—	—	No	RS 232C	Unidirectional	Yes	Yes	Ivory	<b>3S4YR-HNF4</b>
—	R	—	—	—	No	RS 232C	Bidirectional	Yes	Yes	Ivory	<b>3S4YR-HNF4-002</b>
R	R	—	—	—	No	RS 232C	Unidirectional	Yes	Yes	Ivory	<b>3S4YR-HNF6</b>
R	R	—	—	—	No	RS 232C	Bidirectional	Yes	Yes	Ivory	<b>3S4YR-HNF6-002</b>
—	R	R	—	—	No	RS 232C	Unidirectional	Yes	Yes	Ivory	<b>3S4YR-HNF7</b>
—	R	R	—	—	No	RS 232C	Bidirectional	Yes	Yes	Ivory	<b>3S4YR-HNF7-002</b>
—	—	—	—	R	No	RS 232C	Bidirectional	Yes	Yes	Ivory	<b>3S4YR-HNF2-002</b>
—	—	—	—	R	No	RS 232C	Bidirectional	No	No	Ivory	<b>3S4YR-HNF2-012</b>
—	R	—	—	R	No	RS 232C	Unidirectional	Yes	Yes	Ivory	<b>3S4YR-HNF24</b>
—	R	—	—	R	No	RS 232C	Bidirectional	Yes	Yes	Ivory	<b>3S4YR-HNF24-002</b>
—	R	—	—	R	No	RS 232C	Bidirectional	No	No	Ivory	<b>3S4YR-HNF24-012</b>
R	R	—	—	R	No	RS 232C	Bidirectional	Yes	Yes	Ivory	<b>3S4YR-HNF26-002</b>
R	R	—	—	R	No	RS 232C	Bidirectional	No	No	Ivory	<b>3S4YR-HNF26-012</b>

- Note: 1. Communication protocol comes in two types: Unidirectional = response only, and Bidirectional = command/response  
 2. For information regarding keyboard wedge interface models, contact your Omron representative.  
 3. Bidirectional models derive power from the keyboard port, unidirectional models derive power directly from the RS-232 port.

### ■ TYPICAL APPLICATIONS

- POS Systems
- Credit Card Readers
- ID Card Checkers
- PC Peripherals

## Specifications

Part number	HNF	
Recommended card type	ISO 7810, 7811-1 to -5, 7812 & 7813	
Recording method	F2F	
Swipe direction	Reads in either direction	
Communication protocol	Unidirectional (response only) or Bidirectional (command/response)	
Card feeding speed	100 to 1,000 mm/sec. (200 to 1,000 mm/sec. for 3 track stripe card)	
Interface connector	D-sub 9-pin (female) Bidirectional units also have PS/2 connector (mini-din 6-pin)	
Mounting location	Indoors; away from rain, sunlight and dust	
Power supply	Unidirectional: powered from RS-232C port Bidirectional: powered from keyboard port	
Current consumption	Unidirectional, 12 mA dual track, 16 mA triple track	
Ambient temperature	Operation	0 to 45°C (32 to 113°F)
	Storage	-15 to 60°C (5 to 140°F)
Ambient humidity	Operation	30 to 85% RH, with no condensation and absolute air humidity of 23 g/m <sup>3</sup> or less
	Storage	20 to 90% RH, with no condensation and absolute air humidity of 40 g/m <sup>3</sup> or less
Vibration endurance	10 to 150 Hz, single vibration width of 0.15 mm or an acceleration of 19.6 m/s <sup>2</sup> (2 G)	
Shock endurance	196 m/s <sup>2</sup> (20 G)	
Cable length	1500 mm (59.06)	
Dimensions	100 L x 38.6 W x 35.2 H mm (3.94 L x 1.52 W x 1.39 H in)	
Weight	Approx. 185 g (6.53 oz)	
Service life	300,000 passes minimum	

## I/O Information

### ■ INTERFACE CONNECTOR

D-Sub 9-pin (female). Bidirectional uses 6-pin mini-din (male and female)

### ■ INTERFACE METHOD

Conforms to EIA RS-232C

Transmission speed: 9600 bps

Communication method: Half-duplex

Synchronizing method: Start-stop synchronization

Data bit length: 8 bits

Error detection: Even parity

Stop bit: 1 bit

## ■ PIN ASSIGNMENT

(View from PC side)

Pin number	Signal	Description	Input/output
1	CF (DCD)	Loop-back of RTS	Input
2	BB (RXD)	Card data	Input
3	BA (TXD)	Command data (bidirectional models)	Output
4	CD (DTR)	Always ON at PC side	Output
5	AB (SG)	Signal ground	—
6	CC (DSR)	Data Set Ready	Input
7	CA (RTS)	Request to send	Output
8	CB (CTS)	Loop-back of RTS	Input
9	CE (RI)	Open	Input
Frame	AA (FG)	Frame ground	—

## Dimensions

Unit: mm (inch)

HNF-□

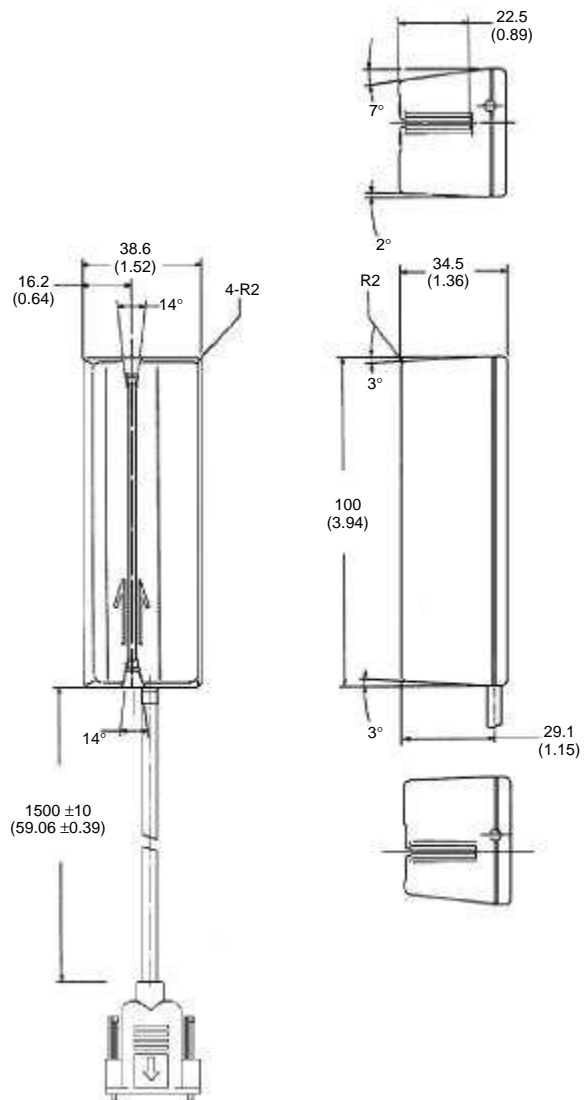

HNF-□-002

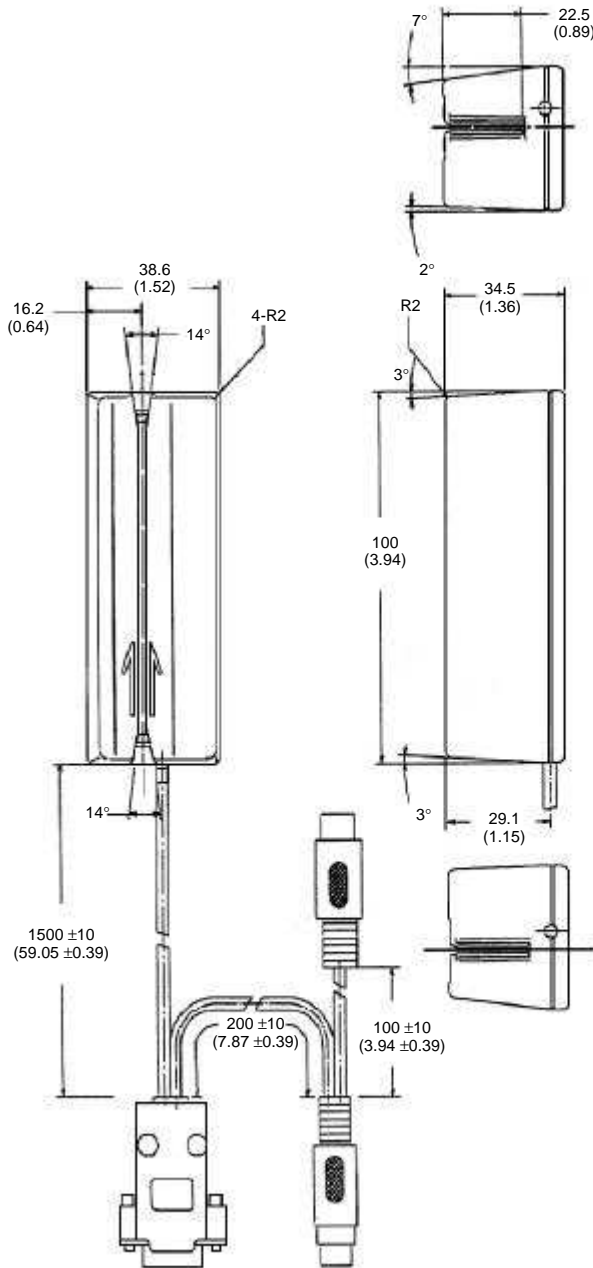

HNF-□-012

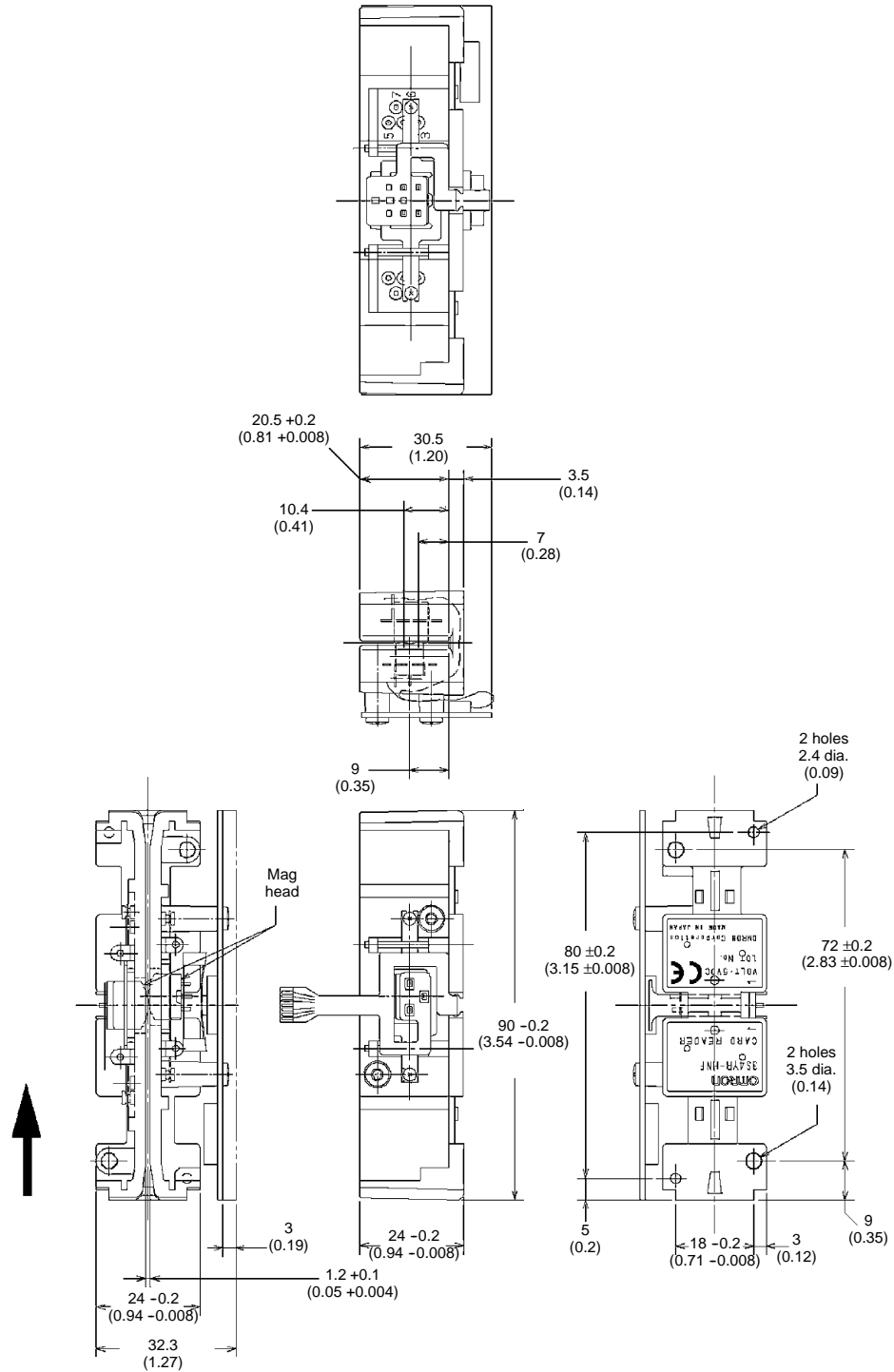

**NOTE: DIMENSIONS SHOWN ARE IN MILLIMETERS. To convert millimeters to inches divide by 25.4.**

---

**OMRON**<sup>®</sup>**OMRON ELECTRONICS, INC.**One East Commerce Drive  
Schaumburg, IL 60173**1-800-55-OMRON****OMRON CANADA, INC.**885 Milner Avenue  
Scarborough, Ontario M1B 5V8**416-286-6465**