



APPLICATIONS

- Kitchen radio
- Clock radio
- CD clock radio
- CD microsystem
- iPod/iPhone docking systems
- Home theatre systems
- Home theatre in box (HTiB) systems

OVERVIEW

Venice 9 is the first Frontier Silicon low-cost digital radio module optimised for slave mode only operation. It is based on the latest DAB/DAB+/DMB-Radio Kino 3 baseband chip. Ideal for emerging DAB+, DMB-Radio and existing DAB markets, it provides additional features and enhanced performance in a small footprint with optional on-board DAC or I²S digital audio output.

Venice 9 is designed for worldwide applications, to enable production of high-performance dual-band or triband DAB/DAB+/DMB-Radio/FM receivers at low cost. It is optimised for slave mode and operates under the control of an external microcontroller found in mini/micro systems, iPod docking systems, home theatre and other home audio products.

Venice 9 is fully World DMB Profile 1 compliant for worldwide use and is EN 55020 and EN 5942 compliant, thus assuring the very best audio quality in both digital radio and FM analogue radio modes. It also passes stringent Electromagnetic Compatibility (EMC) and FM Immunity tests (BS EN 55013 and BS EN 55020) to enable the use of an external antenna on home audio products

BUILD OPTIONS

PRODUCT CODE		DESCRIPTION
FS2029-	B	Band III/Software FM with RDS
	D	Band III/L Band/Software FM with RDS

Further options are described in the Venice 9 datasheet.

KINO 3 BASEBAND PROCESSOR

The **Kino 3** FS1235 IC is an advanced programmable DAB/DAB+/DMB-Radio baseband receiver, incorporating a number of mixed signal system components as well as advanced peripherals previously only available as discrete additional components, providing significant space and power savings.

KINO 3 ADVANCED
BASEBAND CHIP



FEATURES

- WorldDMB Profile 1 compliant
- Ultra low-power DAB/DAB+/DMB-Radio/FM baseband reception
- DAB (MPEG1) and DAB+/DMB-Radio (AAC+) decoding
- DAB/DAB+/DMB-Radio sensitivity to -99 dBm (typical)
- FM sensitivity to -107 dBm (typical)
- Ultra low-power baseband reception
- Decodes multiple audio services up to 384 kbps
- Temperature range:
 - operation: -10 to +70°C
 - storage: -40 to +85°C
- Memory:
 - Integrated RAM on Kino 3 baseband IC for DAB/DAB+/DMB-Radio and other features
 - 4 Mbit flash
- On-board stereo DAC (optional)
- I²S bus for optional external DAC or codec
- S/PDIF interface
- Serial control interfaces
- Combined antenna input for FM, Band III and L-Band
- RoHS-compliant
- RF input via F-type, SMA, SMB or direct coaxial cable connection
- 14-way or 20-way connector options for I/O flexibility

VENICE 9 FS2029

Low-power, low-cost DAB/DAB+/DMB-Radio/FM tuner slave module

DESCRIPTION

Venice 9 provides a complete low-cost, low-power WorldDMB Profile 1 (DAB/DAB+/DMB-Radio) digital broadcast and FM tuner in a compact module.

The main components of the Venice 9 module are shown in the diagram opposite. These are the RF front-end, Kino 3 baseband processor, flash and optional audio DAC. Hardware interfaces include serial ports (SSI, SCB and UART) for connection to a controlling CPU. Analogue (line-level) and digital (S/PDIF and I²S) outputs are available.

SOFTWARE

Software is configured to customer requirements and pre-installed in the module's flash memory. Software builds are available for the module to be used as slave under control of a host microcontroller using Frontier's robust software interface: Frontier Silicon Application Programming Interface (FSAPI).

DEVELOPMENT PLATFORM

For evaluation and development, the Wolfsburg evaluation platform for digital radio enables manufacturers to evaluate the Venice 9 module and put it through its paces under PC control.

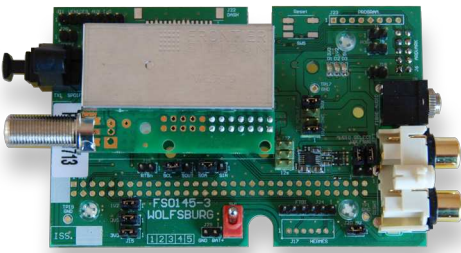

WOLFSBURG EVALUATION PLATFORM WITH VENICE 9 FITTED

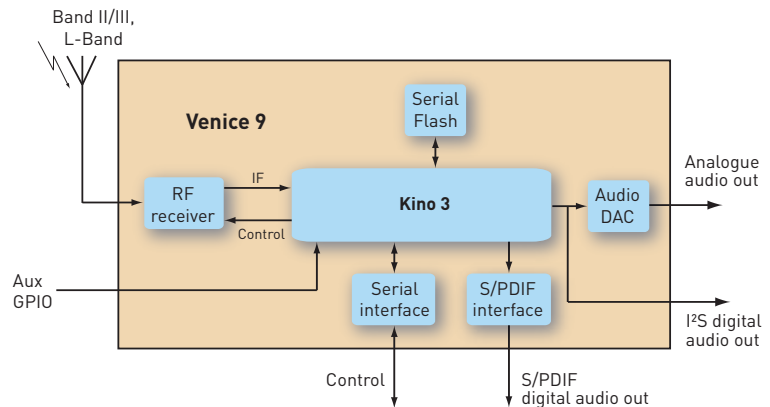

INTERNAL BLOCK DIAGRAM

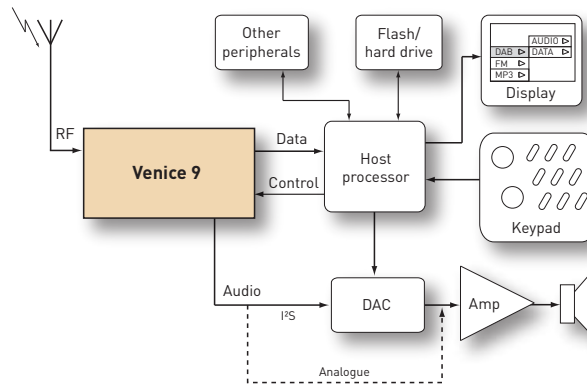

VENICE 9 EXAMPLE IMPLEMENTATION

STANDARDS AND CERTIFICATION

Venice 9 has been designed to exceed the WorldDMB Profile 1 specification for basic digital radio, interoperable throughout Europe and beyond, and also operate seamlessly with the rest of the digital audio world. As well as working with the standards shown, suitable end-products based on this module should be able to obtain certification for various other industry standards including Works with iPhone and Made for iPod; for more information, contact Frontier Silicon.

SPECIFICATION

Supply voltages		3.3 V (baseband I/O and RF) 1.2 V (baseband core)
Power consumption		TBC
DAB/DAB+/DMB-Radio (Band III/L-Band)	Sensitivity	-99 dBm (typ)
	ACR	37 dB (typ)
	FOS	60 dB (typ)
FM	Sensitivity (@ 40 dB SNR)	-107 dBm (typ)
	Stereo separation	30 dB (min)