

VENICE 8.1 MODULE -
65 X 80 MM

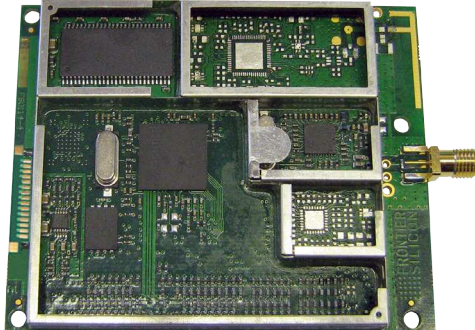

OVERVIEW

The Venice 8.1 FS2028-1 module provides a colour touch radio solution for DAB/DAB+/DMB-Radio and FM-RDS products. It provides the simplest route to market for high-quality touchscreen digital radios. Based around Frontier Silicon's powerful Chorus 3 processor, Venice 8.1 is designed for worldwide application to enable production of high-performance touchscreen dual or tri-band DAB/DAB+/DMB-Radio and FM-RDS receivers.

Venice 8.1 operates in master mode for stand-alone radios. The module includes all interfaces necessary for a fully functional radio, needing only power supply, display, keypad, audio amplifier and speakers to complete a product.

USER INTERFACE

The fully featured colour graphical user interface with touch input provides a modern interface to a new generation of multimedia radio.

The interface opens up quick and convenient access to a variety of audio sources including on-air digital and FM radio, USB memory sticks and iPod docking systems.

The UI supports a variety of navigation options to search through stations independent of broadcast format or DAB, DAB+ or DMB-Radio.



USER INTERFACE

APPLICATIONS

- Colour touch digital radio
- Kitchen radio
- Clock radio
- iPod/DAB docking systems
- USB music systems

FEATURES

- Full colour graphical UI with touch driven interface
- WorldDMB Profile 1 compliant and Profile 2 capable
- DAB (MPEG1) and DAB+/DMB-Radio decoding
- DAB Slideshow (basic and enhanced profile)
- Music player with trick play
- TFT touch colour panel displays
- Hi-Speed USB host interface for music playback and software update
- Memory:
 - Integrated RAM on Chorus 3 baseband IC for DAB/DAB+/DMB-Radio and FM-RDS
 - On-board 32 Mbits Flash and 32 MBytes SDRAM
- On-board stereo 16-bit DAC
- I²S bus for optional external DAC or CODEC
- S/PDIF interface
- UART interface for iPod/iPhone docking
- Ultra low-power baseband
- Infrared remote control
- Serial control interfaces
- Combined antenna input for DAB Band III and FM
- RoHS compliant
- Temperature range:
 - operation: 0 to +70°C
 - storage: -40 to +85°C

VENICE 8.1 FS2028-1

Colour touch radio module for DAB/DAB+/DMB-Radio and FM-RDS

DESCRIPTION

The main components of the Venice 8.1 module are shown in the diagram opposite. These are the DAB/FM RF front-end (Apollo 2), Chorus 3 baseband processor, Flash, SDRAM, TFT display interface and audio DAC. Analogue (line-level) and digital (S/PDIF and I²S) outputs are available.

CHORUS 3 BASEBAND PROCESSOR

The **Chorus 3** FS1230 baseband processor is the latest generation of integrated system-on-chip, providing an optimised solution for WorldDMB Profile 1, Profile 2, DAB, DAB+, DMB-Radio and FM-RDS broadcast receiver products. It incorporates a number of mixed-signal system components as well as an applications processor and advanced peripherals, providing significant space, cost and power savings.

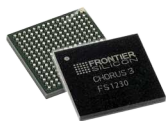

CHORUS 3 ADVANCED BASEBAND CHIP

SOFTWARE

Frontier silicon has made considerable investment in creating the most versatile and intuitive graphical touch UI available anywhere. Venice 8.1 uses IR 3.2 software, which is customisable to OEM's individual requirements. IR 3.2 features DAB Slideshow, an innovative technology which allows broadcasters to send full colour images alongside their audio content resulting in a rich multimedia radio experience.



EXAMPLES OF DAB SLIDESHOW

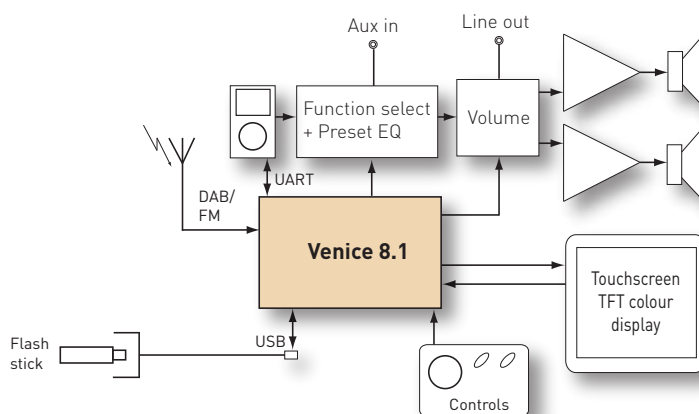

TYPICAL VENICE 8.1 APPLICATION

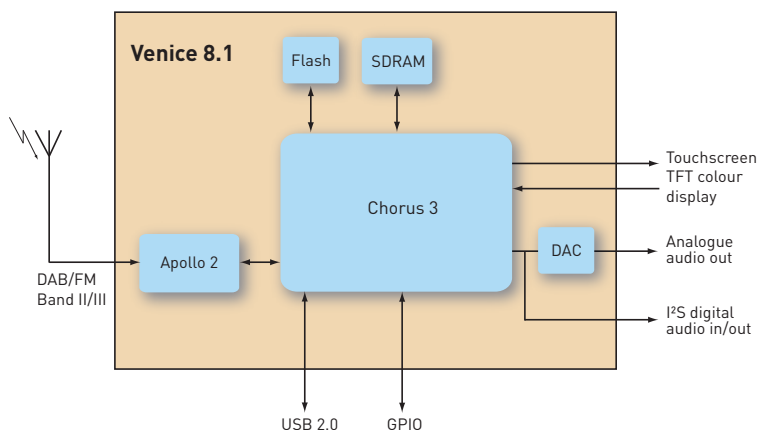

INTERNAL BLOCK DIAGRAM

DEVELOPMENT PLATFORM

For evaluation and development, the Jupiter 8.1 production ready platform for digital radio and iPod docking enables manufacturers to quickly develop differentiated end-products.

STANDARDS AND CERTIFICATION

Venice 8.1, Jupiter 8.1 reference platform and software have been designed to operate seamlessly with the rest of the digital audio world. As well as working with the standards shown, suitable end-products based on this platform should be able to obtain certification for various other industry standards; such as CE approval, iPod and iPhone certification,

For more information, contact Frontier Silicon.

