

KINO 3 CHIP

APPLICATIONS

- Profile 1 WorldDMB digital radio receivers
- DAB
- DAB+
- DMB-Radio
- FM-RDS

OVERVIEW

The Kino 3 baseband processor is the latest generation of integrated system-on-chip, providing an optimised solution for WorldDMB Profile 1 DAB/DAB+/DMB-R and FM-RDS broadcast receivers.

Kino 3 is an advanced programmable baseband receiver capable of receiving DAB/DAB+ and DMB-R broadcasts. It incorporates a number of mixed signal system components as well as advanced peripherals previously only available as discrete additional components, providing significant space, cost and power savings.

The CPU provides the processing power to receive digital radio and operate the user interface in the system. It is powerful enough to be the master processor in any digital radio system.

Coupled to the CPU are a host of interfaces that allow interfacing to displays, external memory storage and PCs, allowing Kino 3-based receivers to connect to other devices with minimal additional components.

ADVANCED POWER MANAGEMENT

Kino 3 uses dynamic and static power management techniques including fully-static design, clock-gating and inactive period state minimisation for low power usage without compromising performance. The processor clock is generated by a PLL which can be reprogrammed dynamically, enabling power consumption to be minimised for specific applications.

EVALUATION

Kino 3 is available with a full suite of software in the Verona/Venus product range.



Actual size

64 pin QFN

9 x 9, 0.5 mm pitch

FEATURES

- CPU 166MHz META122 RISC/DSP multithreaded
- Memory configurable between system and TCM (Tightly Coupled Memory)
- 64K ROM located in TCM space for boot and library functions
- Onboard memory for DAB/DAB+/DMB-R
- Analogue interface to DAB RF for zero and low IF
- USB 2.0 HS host/device
- Up to 4 PDM DAC outputs
- Standard 16550 UART
- SCB 2-wire bus (I²C-compatible)
- S/PDIF audio output
- 10-bit ADC
- Temperature range
 - Operating -40 to +85 °C
 - Storage -40 to +125 °C
- Full RoHS compliance

KINO 3 FS1235

Advanced digital radio and audio baseband processor

EXTENSIVE INTERFACES

- **10/100 Ethernet** MAC interface to external PHY
- **USB 2.0** interface with support for full-speed (12 Mbps) and high-speed (480 Mbps) operation
- Integrated support for **TFT** and **LCD** displays
- **SD** interface for optional mass storage applications
- Extensive and flexible **GPIO**
- **S/PDIF** audio output
- Up to 8-channel I²S output of decoded audio data (both master and slave modes)
- Support for 5 **SPI slave** devices (including DMB TS data output, SD card profile and optional local SPI Flash)
- SPI slave port available for MSC/TS data output and control to/from host
- 3 SCB (I²C-compatible) ports for control of RF device and optional control from host
- 4 PDM DAC outputs for interface to RF tuners and other applications
- 16 550-compliant **UART** with optional flow control
- **JTAG** interface for test and emulator support
- Support for expansion RAM (SRAM, Cellular SRAM, SDRAM or mobile SDRAM) for the most demanding applications.

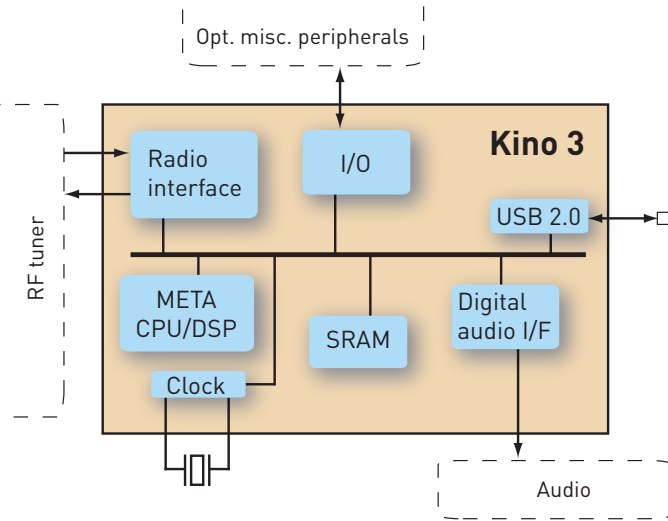

SIMPLIFIED BLOCK DIAGRAM

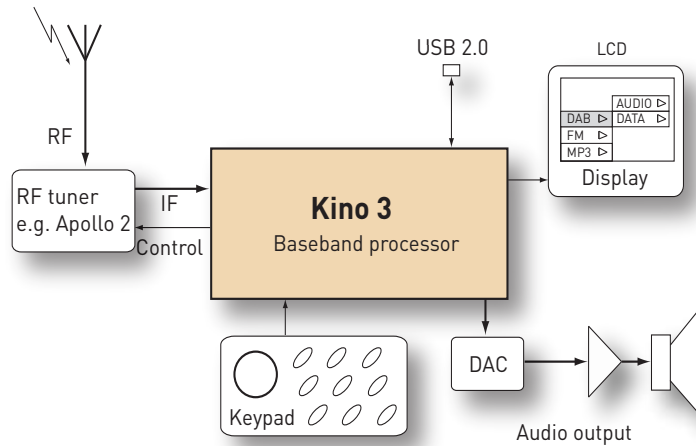

EXAMPLE DAB/DAB+/DMB-R/FM APPLICATION

ARCHITECTURE

The META multithreaded core is a high-performance low-power modular device enabling extensive customisation. It is designed for use in applications such as audio signal processing and next-generation digital wireless.

Processor architecture	Multithreaded 3-operand register based
Data types and registers	16/32-bit integer ALU with multiple 32-bit register files
System architecture	Independent 64-bit instruction and data interfaces
Exceptions and interrupts	Memory, instruction, and interrupt handling on each thread
Instruction set	RISC 32-bit with 64-bit extensions
Pipeline	3-stage

